

บทที่ 10

การทดสอบและอัปโหลดโปรแกรม

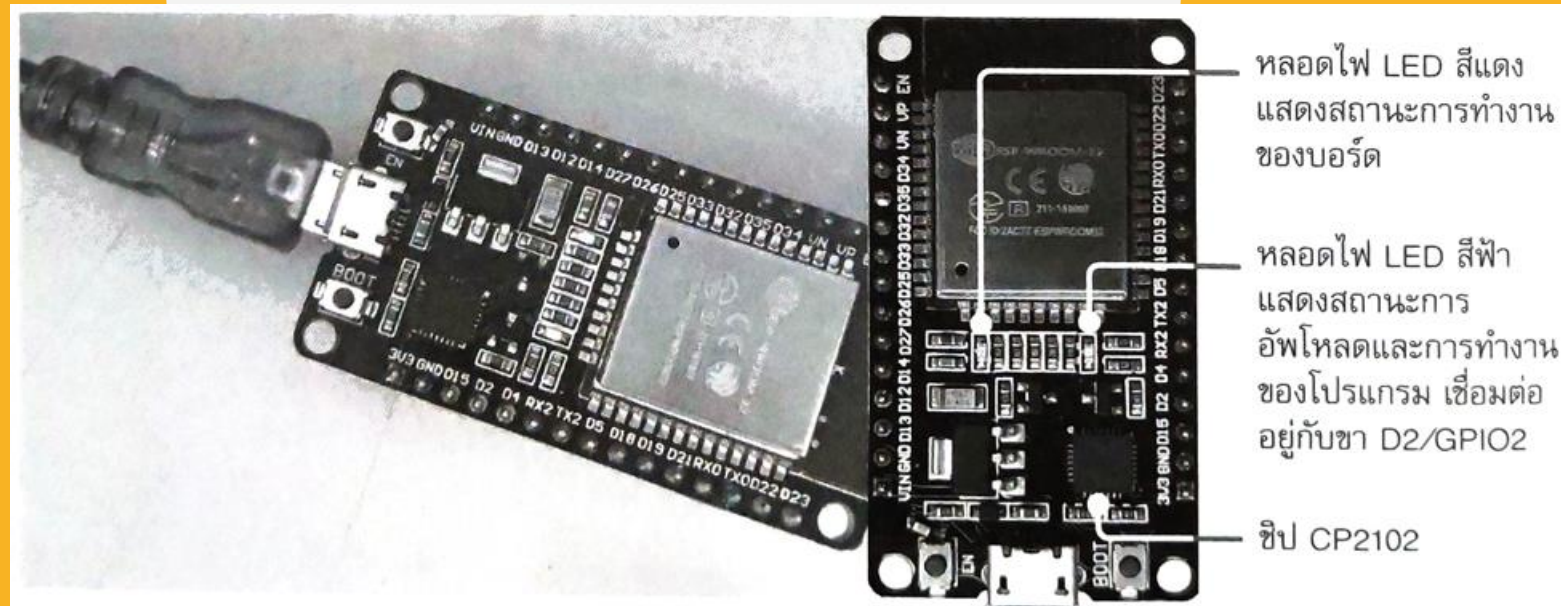

จุดประสงค์การเรียนรู้

1. ศึกษาการทดสอบบอร์ดทดลอง ESP32
2. ศึกษาการใช้งาน Serial Monitor ดูข้อมูลที่ส่งออกจากบอร์ดทดลอง ESP32
3. ศึกษาการใช้งาน Serial ส่งข้อมูลจากแป้นพิมพ์ไปยังบอร์ด
4. ศึกษาการใช้งาน Serial Plotter

บอร์ด NodeMCU ESP32

การอัปโหลด (Upload)



Arduino



Arduino IDE

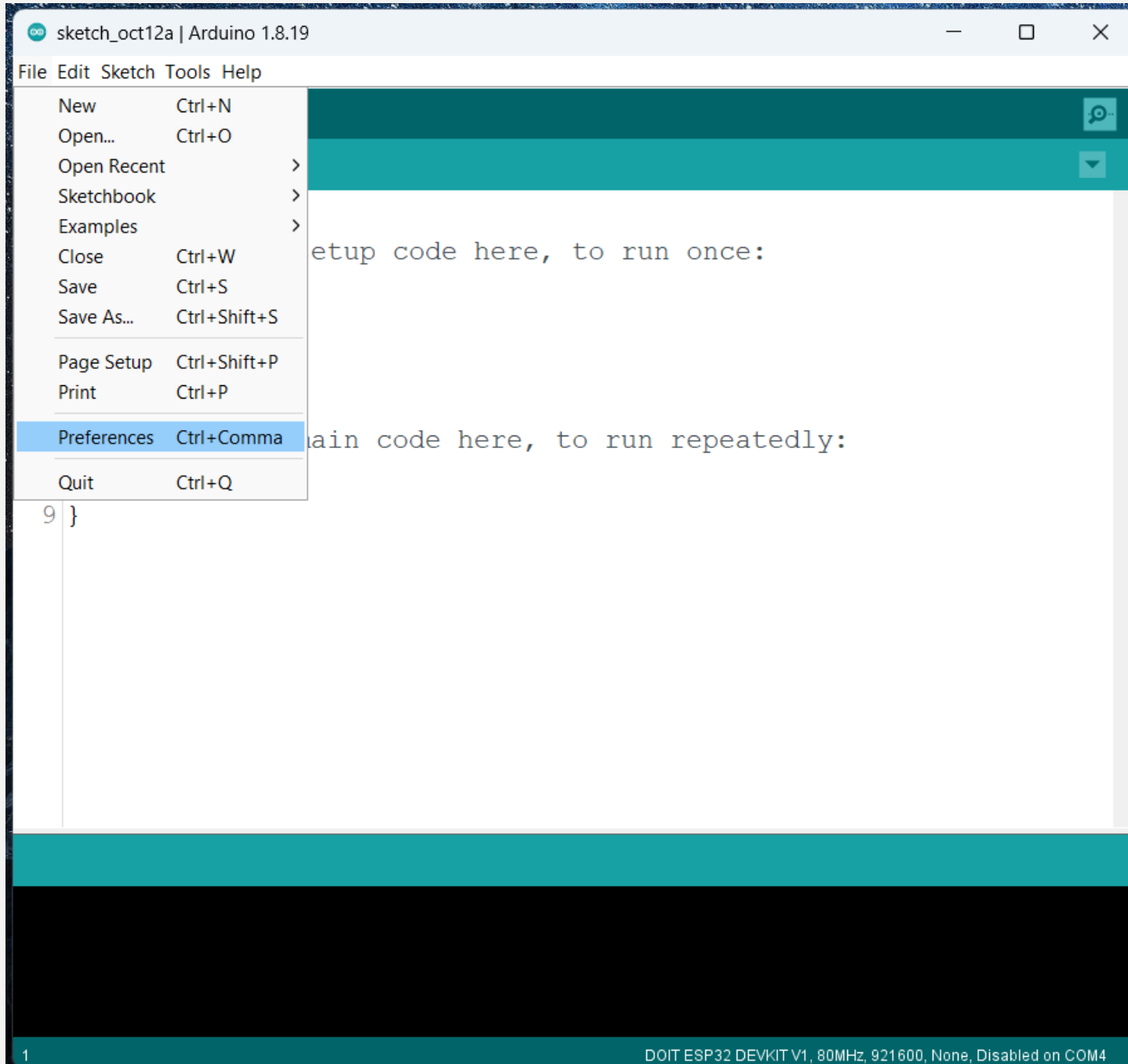

https://espressif.github.io/arduino-esp32/package_esp32_index.json

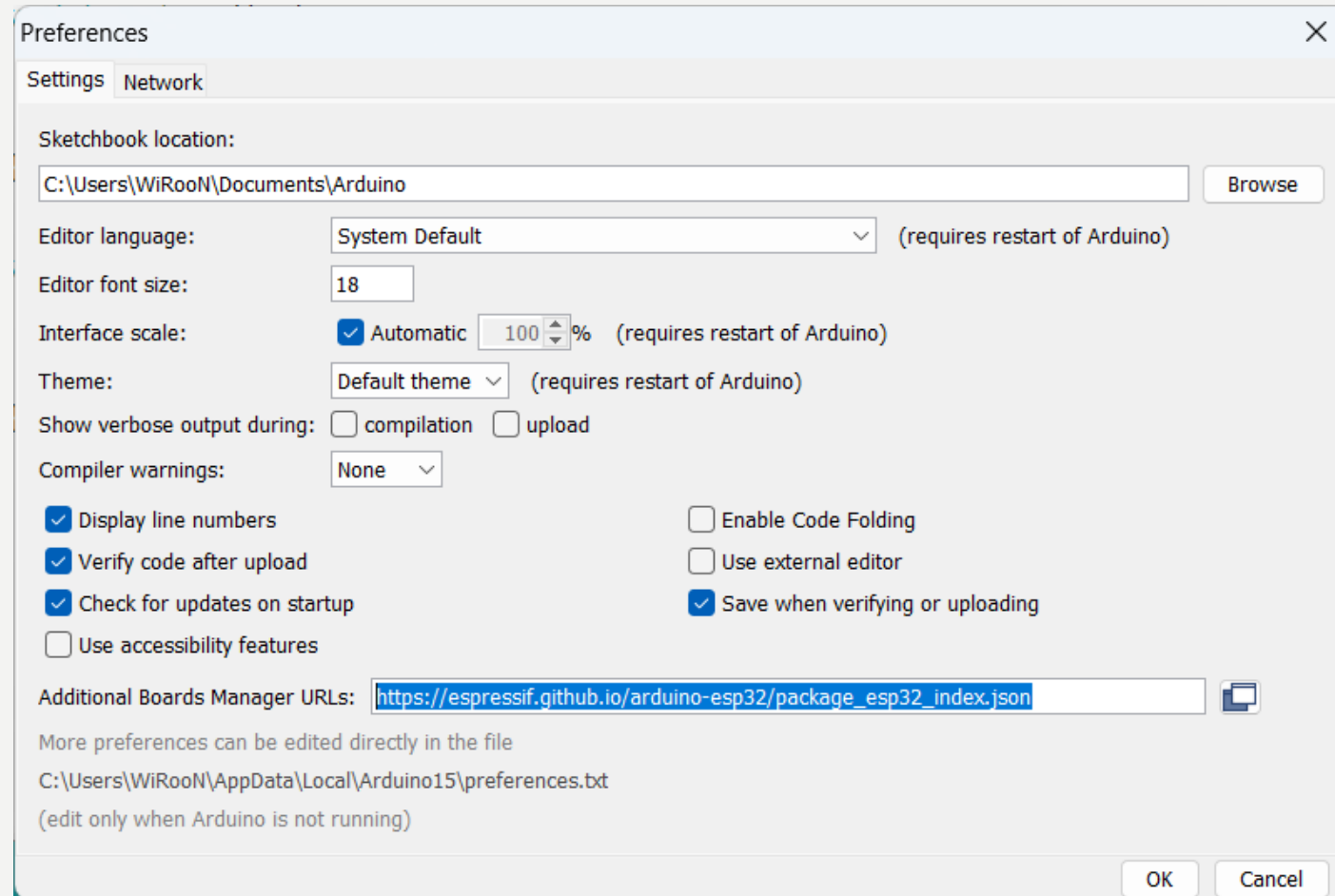

sketch_oct12a | Arduino 1.8.19

File Edit Sketch Tools Help

Auto Format Ctrl+T

Archive Sketch

Fix Encoding & Reload

Manage Libraries... Ctrl+Shift+I

Serial Monitor Ctrl+Shift+M

Serial Plotter Ctrl+Shift+L

WiFi101 / WiFinINA Firmware Updater

Board: "DOIT ESP32 DEVKIT V1" > Boards Manager...

Upload Speed: "921600" > Arduino AVR Boards >

Flash Frequency: "80MHz" > ESP32 Arduino >

Core Debug Level: "None" > tedly:

Erase All Flash Before Sketch Upload: "Disabled" >

Port: "COM4" >

Get Board Info

Programmer >

Burn Bootloader

```
1 void s
2 // p
3
4 }
5
6 void l
7 // p
8
9 }
```

1 DOIT ESP32 DEVKIT V1, 80MHz, 921600, None, Disabled on COM4

Boards Manager

Type All

Arduino ESP32 Boards
by **Arduino**
Boards included in this package:
Arduino Nano ESP32.
[More Info](#)

esp32
by **Espressif Systems** version **2.0.17** **INSTALLED**
Boards included in this package:
ESP32 Dev Board, ESP32-S2 Dev Board, ESP32-S3 Dev Board, ESP32-C3 Dev Board, Arduino Nano ESP32.
[More Info](#)

sketch_oct12a | Arduino 1.8.19

File Edit Sketch Tools Help

```
1 void s
2 // p
3
4 }
5
6 void l
7 // p
8
9 }
```

Auto Format Ctrl+T

Archive Sketch

Fix Encoding & Reload

Manage Libraries... Ctrl+Shift+I

Serial Monitor Ctrl+Shift+M

Serial Plotter Ctrl+Shift+L

WiFi101 / WiFININA Firmware Updater

Board: "ESP32-WROOM-DA Module" >

Upload Speed: "921600" >

CPU Frequency: "240MHz (WiFi/BT)" >

Flash Frequency: "80MHz" >

Flash Mode: "QIO" >

Flash Size: "4MB (32Mb)" >

Partition Scheme: "Default 4MB with spiiffs (1.2MB APP/1.5MB SPIFFS)" >

Core Debug Level: "None" >

Arduino Runs On: "Core 1" >

Events Run On: "Core 1" >

Erase All Flash Before Sketch Upload: "Disabled" >

Port: "COM4" >

Get Board Info

Programmer >

Burn Bootloader

Boards Manager...

Arduino AVR Boards >

ESP32 Arduino >

- Adafruit Feather ESP32-S2
- Adafruit Feather ESP32-S2 TFT
- Adafruit Feather ESP32-S2 Reverse T
- Adafruit Feather ESP32-S3 2MB PSR
- Adafruit Feather ESP32-S3 No PSRA
- Adafruit Feather ESP32-S3 TFT
- Adafruit Feather ESP32-S3 Reverse T
- Adafruit QT Py ESP32
- Adafruit QT Py ESP32-C3
- Adafruit QT Py ESP32-S2
- Adafruit QT Py ESP32-S3 No PSRAM
- Adafruit QT Py ESP32-S3 (4M Flash ;
- Adafruit ItsyBitsy ESP32
- Adafruit MatrixPortal ESP32-S3
- Adafruit pyCamera S3
- Adafruit Qualia ESP32-S3 RGB666
- NodeMCU-32S
- MH ET LIVE ESP32DevKIT
- MH ET LIVE ESP32MiniKit
- ESP32vn IoT Uno
- DOIT ESP32 DEVKIT V1**
- DOIT ESPduino32
- OLIMEX ESP32-EVB
- OLIMEX ESP32-GATEWAY
- OLIMEX ESP32-PoE
- OLIMEX ESP32-PoE-ISO
- OLIMEX ESP32-DevKit-LiPo

WROOM-DA Module, Default 4MB with spiiffs (1.2MB APP/1.5MB SPIFFS), 240MHz (WiFi/BT), QIO, 80MHz, 4MB (32Mb), 921600, Core 1, Core 1, None, Disabled on COM4

sketch_oct12a | Arduino 1.8.19

File Edit Sketch Tools Help

Auto Format Ctrl+T

Archive Sketch

Fix Encoding & Reload

Manage Libraries... Ctrl+Shift+I

Serial Monitor Ctrl+Shift+M

Serial Plotter Ctrl+Shift+L

WiFi101 / Wi-FiNINA Firmware Updater

Board: "DOIT ESP32 DEVKIT V1" >

Upload Speed: "921600" >

Flash Frequency: "80MHz" >

Core Debug Level: "None" >

Erase All Flash Before Sketch Upload: "Disabled" >

Port: "COM4" >

Get Board Info

Programmer >

Burn Bootloader

Serial ports

✓ COM4

```
1 void s
2 // p
3
4 }
5
6 void l
7 // p
8
9 }
```

tedly:

1 DOIT ESP32 DEVKIT V1, 80MHz, 921600, None, Disabled on COM4

ทดสอบโปรแกรม

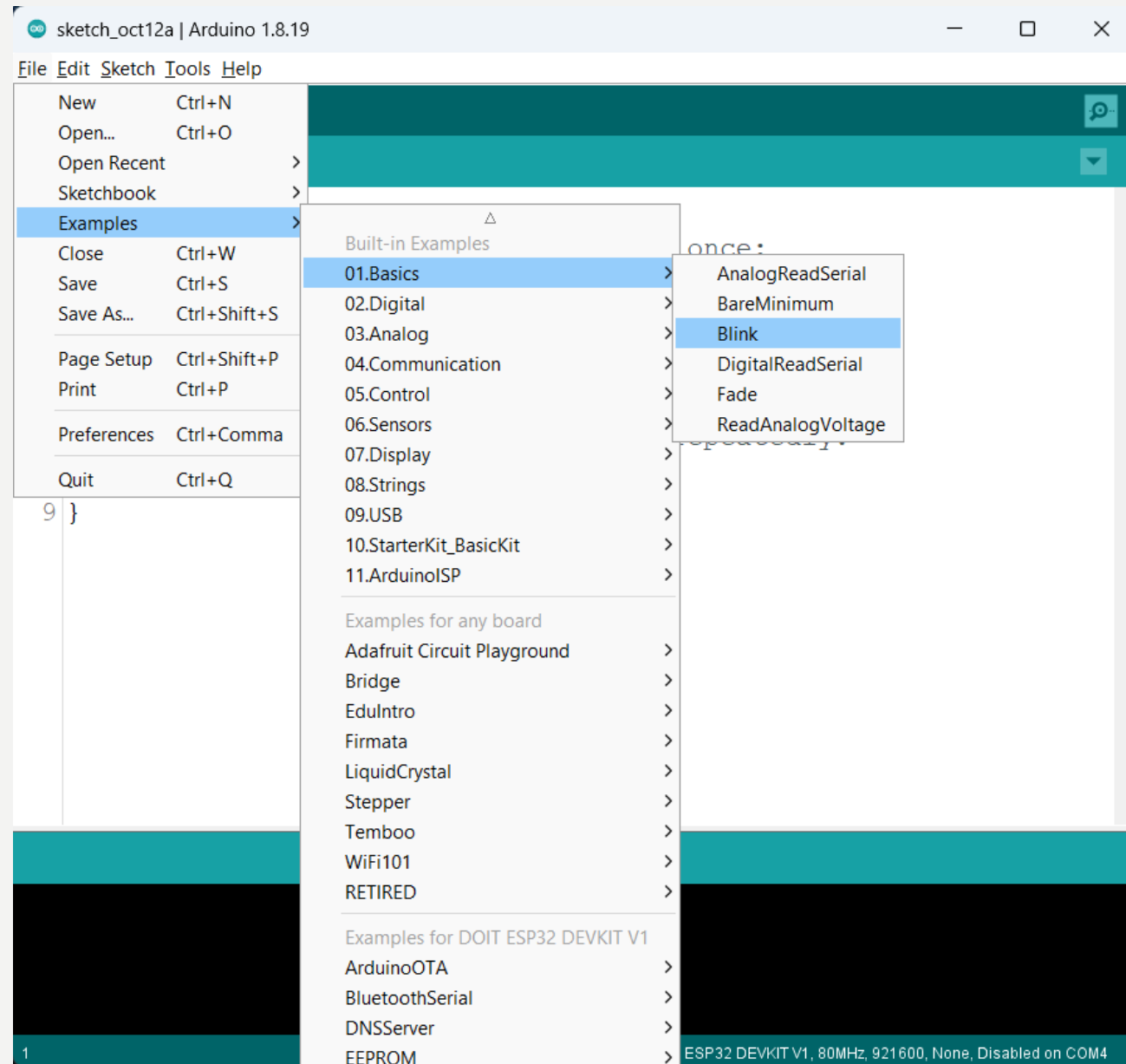

```
Blink | Arduino 1.8.19
File Edit Sketch Tools Help
Blink
1 /*
2  Blink
3
4  Turns an LED on for one second, then off for one second, repea
5
6  Most Arduinos have an on-board LED you can control. On the UNO
7  it is attached to digital pin 13, on MKR1000 on pin 6. LED_BUI
8  the correct LED pin independent of which board is used.
9  If you want to know what pin the on-board LED is connected to
10 model, check the Technical Specs of your board at:
11 https://www.arduino.cc/en/Main/Products
12
13 modified 8 May 2014
14 by Scott Fitzgerald
15 modified 2 Sep 2016
16 by Arturo Guadalupi
```

```
Blink | Arduino 1.8.19
File Edit Sketch Tools Help
Blink
22 https://www.arduino.cc/en/Tutorial/BuiltInExamples/Blink
23 */
24
25 // the setup function runs once when you press reset or power th
26 void setup() {
27   // initialize digital pin LED_BUILTIN as an output.
28   pinMode(LED_BUILTIN, OUTPUT);
29 }
30
31 // the loop function runs over and over again forever
32 void loop() {
33   digitalWrite(LED_BUILTIN, HIGH); // turn the LED on (HIGH is
34   delay(1000); // wait for a second
35   digitalWrite(LED_BUILTIN, LOW); // turn the LED off by maki
36   delay(1000); // wait for a second
37 }
```

Blink | Arduino 1.8.19

File Edit Sketch Tools Help

Upload

Blink

```
22 https://www.arduino.cc/en/Tutorial/BuiltInExamples/Blink
23 */
24
25 // the setup function runs once when you press reset or power th
26 void setup() {
27     // initialize digital pin LED_BUILTIN as an output.
28     pinMode(LED_BUILTIN, OUTPUT);
29 }
30
31 // the loop function runs over and over again forever
32 void loop() {
33     digitalWrite(LED_BUILTIN, HIGH); // turn the LED on (HIGH is
34     delay(1000); // wait for a second
35     digitalWrite(LED_BUILTIN, LOW); // turn the LED off by maki
36     delay(1000); // wait for a second
37 }
```

1

DOIT ESP32 DEVKIT V1, 80MHz, 921600, None, Disabled on COM4

```
Blink | Arduino 1.8.19
File Edit Sketch Tools Help
Blink
22 https://www.arduino.cc/en/Tutorial/BuiltInExamples/Blink
23 */
24
25 // the setup function runs once when you press reset or power th
26 void setup() {
27   // initialize digital pin LED_BUILTIN as an output.
28   pinMode(LED_BUILTIN, OUTPUT);
29 }
30
31 // the loop function runs over and over again forever
32 void loop() {
33   digitalWrite(LED_BUILTIN, HIGH); // turn the LED on (HIGH is
34   delay(1000); // wait for a second
35   digitalWrite(LED_BUILTIN, LOW); // turn the LED off by maki
36   delay(1000); // wait for a second
37 }
Uploading...
Global variables use static space (2K) of dynamic memory, leaving 0
esptool.py v4.5.1
Serial port COM4
Connecting.....
1 DOIT ESP32 DEVKIT V1, 80MHz, 921600, None, Disabled on COM4
```

Blink | Arduino 1.8.19

File Edit Sketch Tools Help

Blink

```
22 https://www.arduino.cc/en/Tutorial/BuiltInExamples/Blink
23 */
24
25 // the setup function runs once when you press reset or power th
26 void setup() {
27   // initialize digital pin LED_BUILTIN as an output.
28   pinMode(LED_BUILTIN, OUTPUT);
29 }
30
31 // the loop function runs over and over again forever
32 void loop() {
33   digitalWrite(LED_BUILTIN, HIGH); // turn the LED on (HIGH is
34   delay(1000); // wait for a second
35   digitalWrite(LED_BUILTIN, LOW); // turn the LED off by maki
36   delay(1000); // wait for a second
37 }
```

Done uploading.

Leaving...

Hard resetting via RTS pin...

1 DOIT ESP32 DEVKIT V1, 80MHz, 921600, None, Disabled on COM4

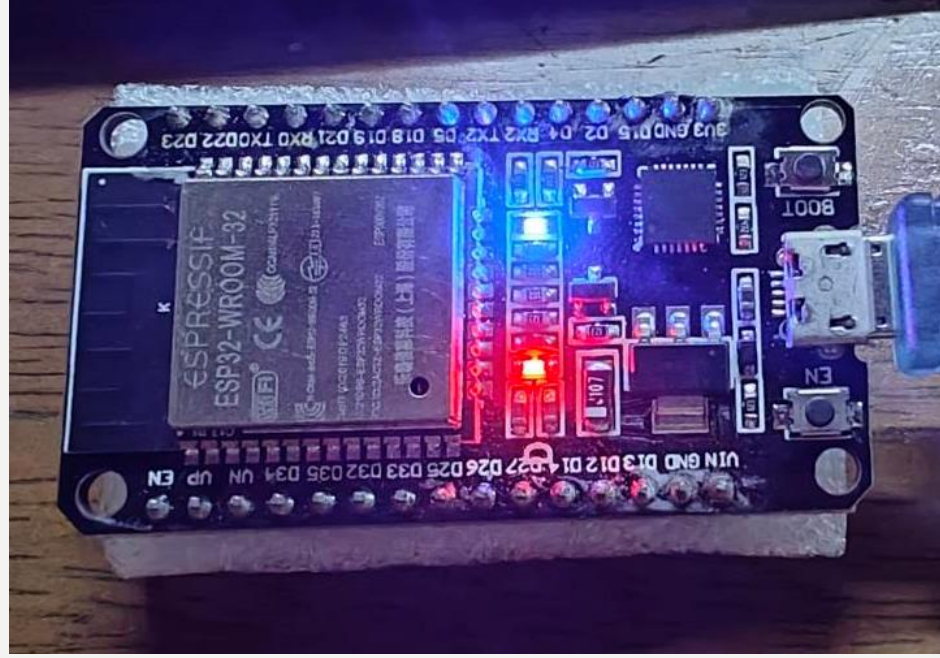
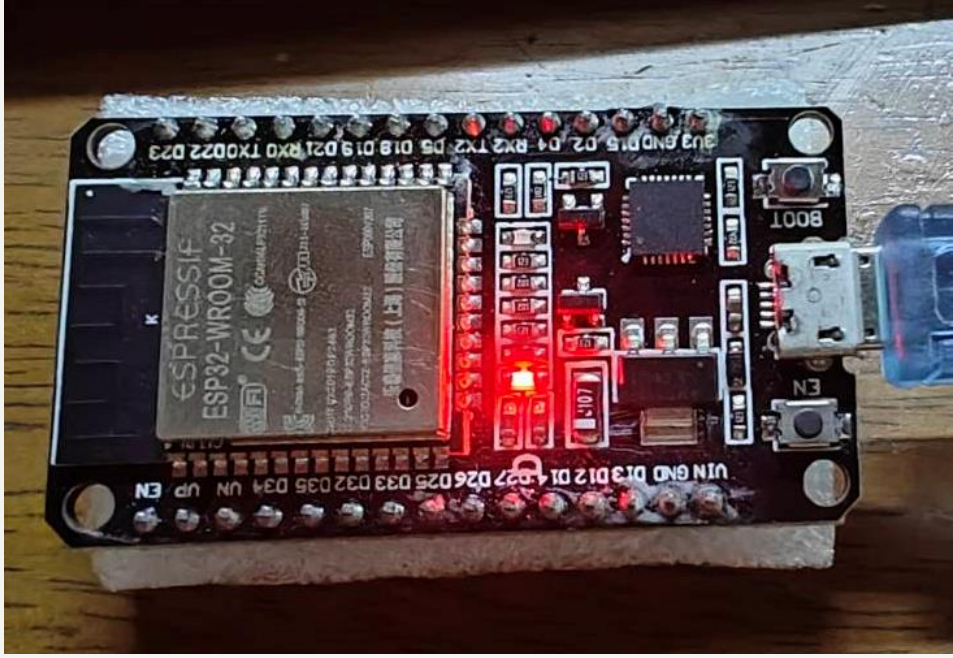



sketch_oct12b \$

```
1 //-----Header-----
2 #include <Wire.h>
3
4 //-----void setup()-----
5 void setup() {
6   Wire.begin();
7   Serial.begin (115200);
8   while (!Serial);
9 }
10 //-----void loop()-----
11 void loop() {
12   Serial.println ("\nScanning...");
13   for (byte i = 8; i < 120; i++) {
14     Wire.beginTransaction (i);
15     if (Wire.endTransmission () == 0) {
16       Serial.print ("LCD Module Address: ");
17       Serial.print (i, DEC);
18       Serial.print (" (0x");
19       Serial.print (i, HEX);
20       Serial.println("\n");
21     }
22   }
23   delay(5000);
24 }
25
```

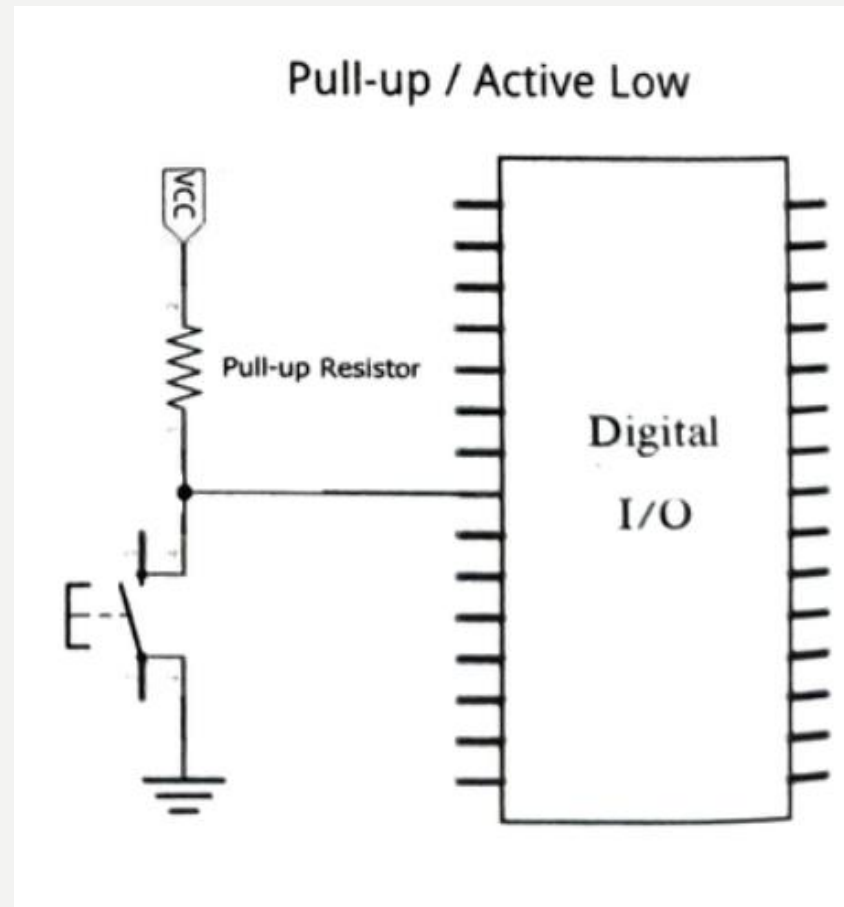

การต่อวงจรให้อุปกรณ์ทำงานในแบบ Active Low/Active High

Active Low หรือ Pull-Up

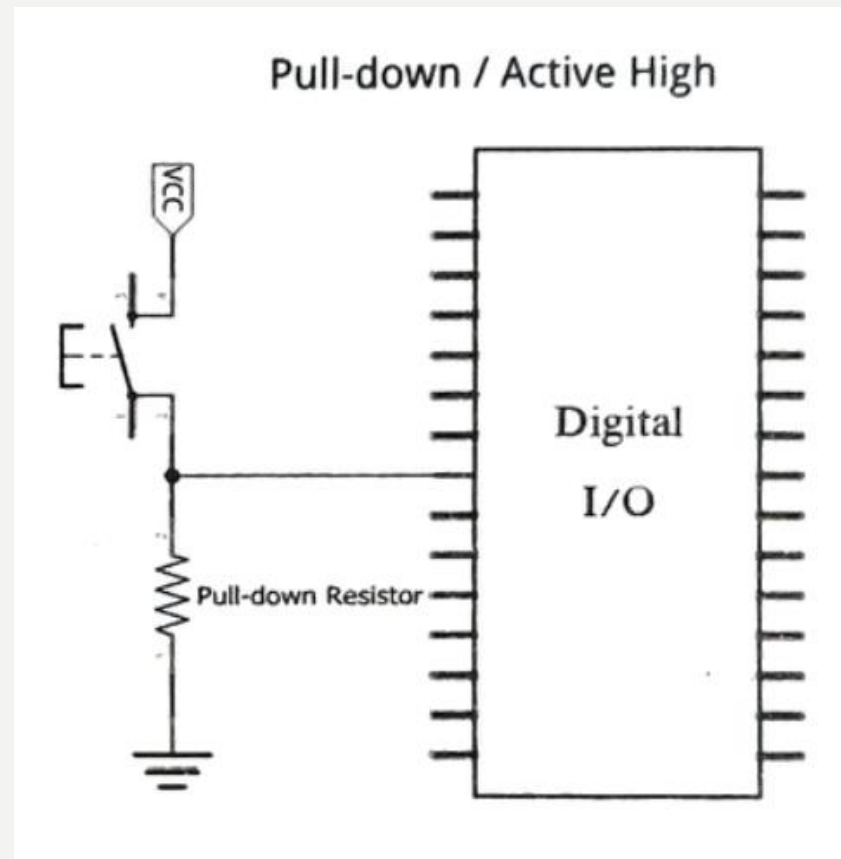

Active High หรือ Pull-Down

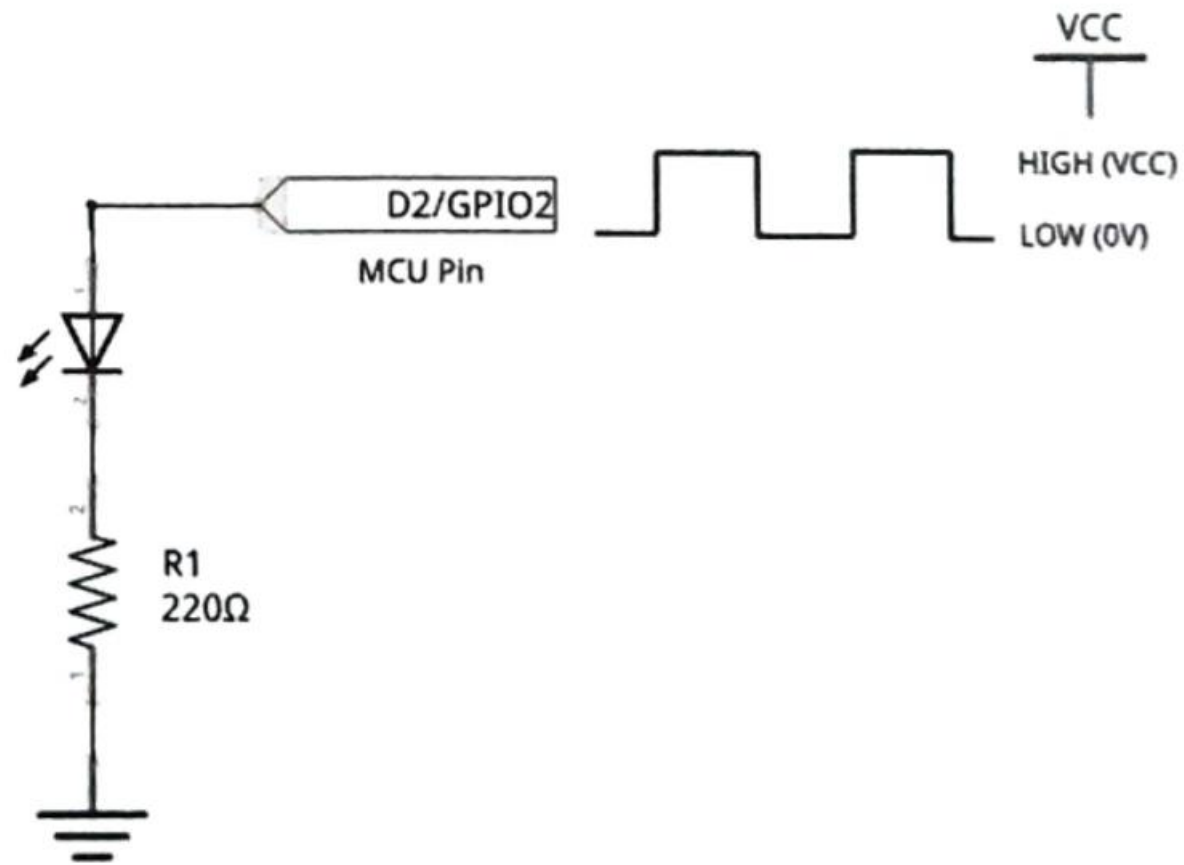



การต่อวงจรของหลอดไฟ LED แบบ Built-in ที่ติดตั้งมากับบอร์ด

การใช้ Serial Monitor



The image shows a screenshot of the Arduino IDE interface. The window title is "page62 | Arduino 1.8.19". The menu bar includes "File", "Edit", "Sketch", "Tools", and "Help". Below the menu bar is a toolbar with icons for checking, running, saving, uploading, and downloading, along with a search icon. The main editor area shows a sketch named "page62 §" with the following code:

```
1 void setup() {  
2   Serial.begin(115200);  
3   delay(1000);  
4   Serial.print("Hello Test. ");  
5   Serial.print("I am testing a program");  
6 }  
7  
8 void loop() {  
9  
10 }  
11 |
```

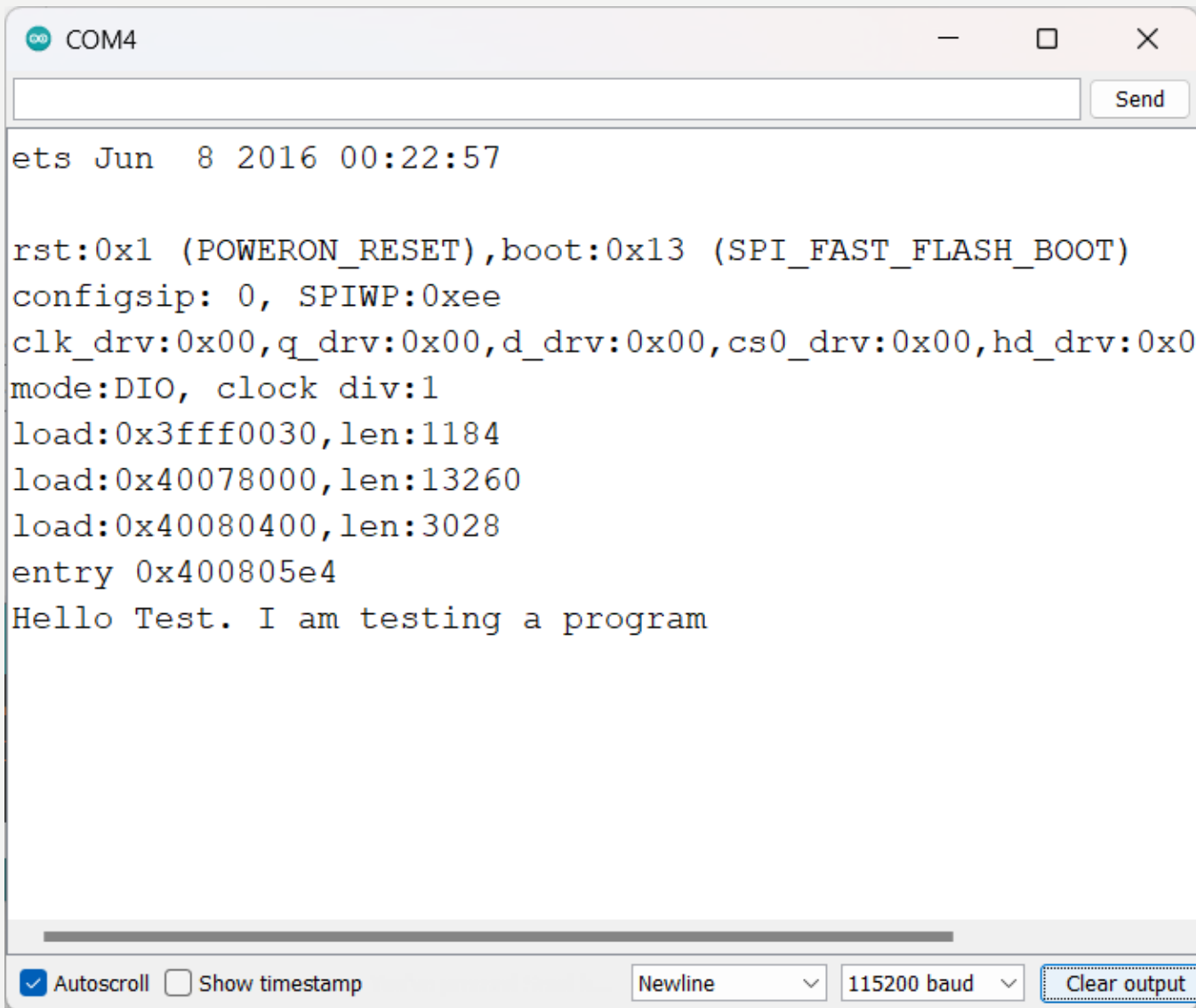

The image shows a serial terminal window with the title 'COM4'. At the top, there is a text input field and a 'Send' button. The main area contains the following text:

```
ets Jun  8 2016 00:22:57

rst:0x1 (POWERON_RESET),boot:0x13 (SPI_FAST_FLASH_BOOT)
configsip: 0, SPIWP:0xee
clk_drv:0x00,q_drv:0x00,d_drv:0x00,cs0_drv:0x00,hd_drv:0x00
mode:DIO, clock div:1
load:0x3fff0030,len:1184
load:0x40078000,len:13260
load:0x40080400,len:3028
entry 0x400805e4
Hello Test. I am testing a program
```

At the bottom of the window, there are several controls: a checked 'Autoscroll' checkbox, an unchecked 'Show timestamp' checkbox, a 'Newline' dropdown menu, a '115200 baud' dropdown menu, and a 'Clear output' button.



The image shows a screenshot of the Arduino IDE interface. The window title is "page63 | Arduino 1.8.19". The menu bar includes "File", "Edit", "Sketch", "Tools", and "Help". The toolbar contains icons for a checkmark, a right arrow, a grid, an upload button, a download button, and a search icon. The file name "page63" is displayed in the top right of the editor area. The code is as follows:

```
1 void setup() {
2   Serial.begin(115200);
3   delay(100);
4   Serial.print("Hello Test.");
5   Serial.println("I am testing a program");
6   int a, b, c;
7   a = 10;
8   b = 20;
9   c = a + b;
10  Serial.print("Value a = ");
11  Serial.println(a);
12  Serial.print("Value b = ");
13  Serial.println(b);
14  Serial.print("Value c = ");
15  Serial.println(c);
16 }
17
18 void loop() {
19
20 }
```

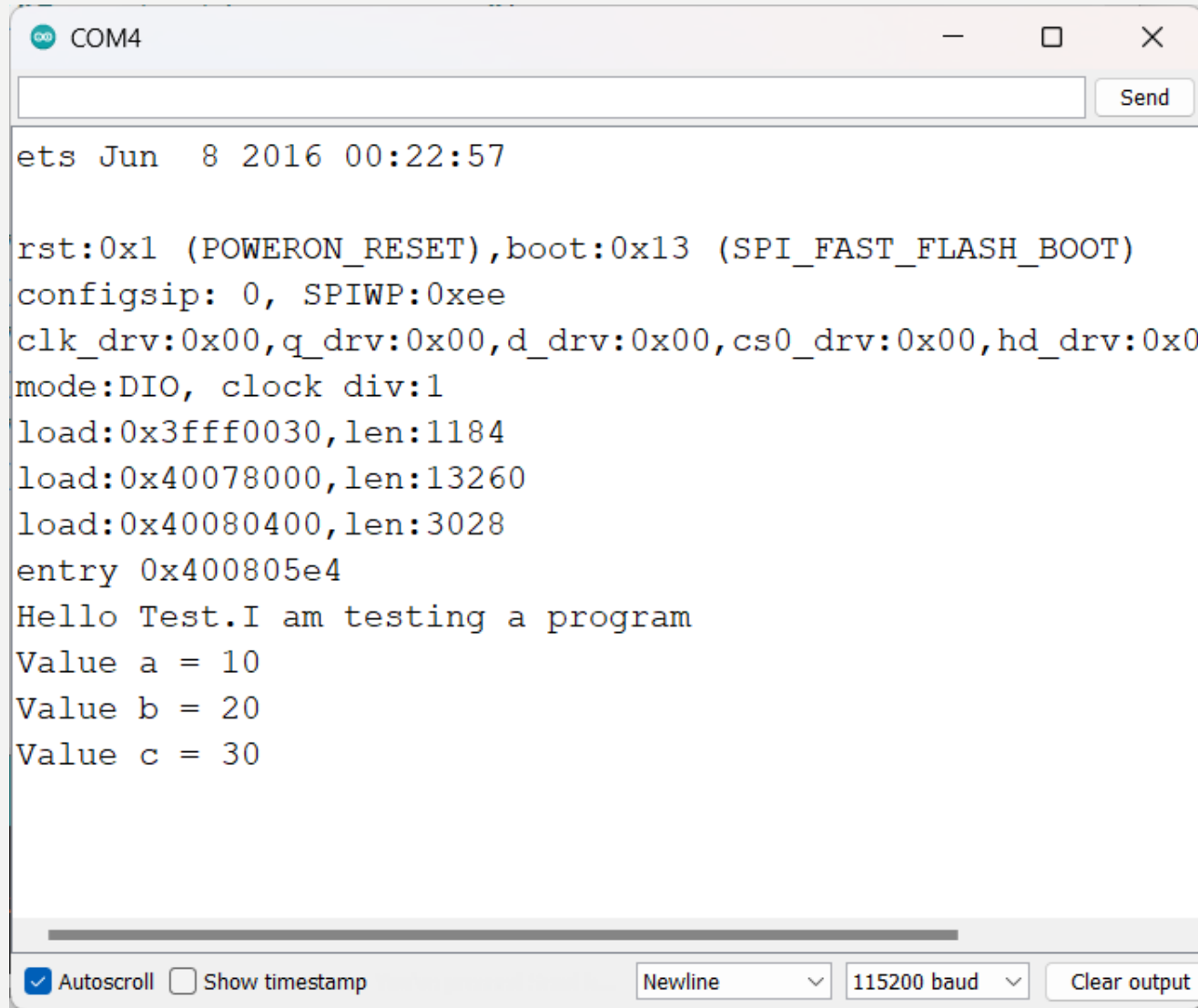

The image shows a serial terminal window titled "COM4". The window contains the following text:

```
ets Jun  8 2016 00:22:57

rst:0x1 (POWERON_RESET),boot:0x13 (SPI_FAST_FLASH_BOOT)
configsip: 0, SPIWP:0xee
clk_drv:0x00,q_drv:0x00,d_drv:0x00,cs0_drv:0x00,hd_drv:0x00
mode:DIO, clock div:1
load:0x3fff0030,len:1184
load:0x40078000,len:13260
load:0x40080400,len:3028
entry 0x400805e4
Hello Test.I am testing a program
Value a = 10
Value b = 20
Value c = 30
```

At the bottom of the window, there are several controls: a checked "Autoscroll" checkbox, an unchecked "Show timestamp" checkbox, a "Newline" dropdown menu, a "115200 baud" dropdown menu, and a "Clear output" button.

การใช้ Serial Monitor ดูข้อมูลที่ส่งออกจากบอร์ด

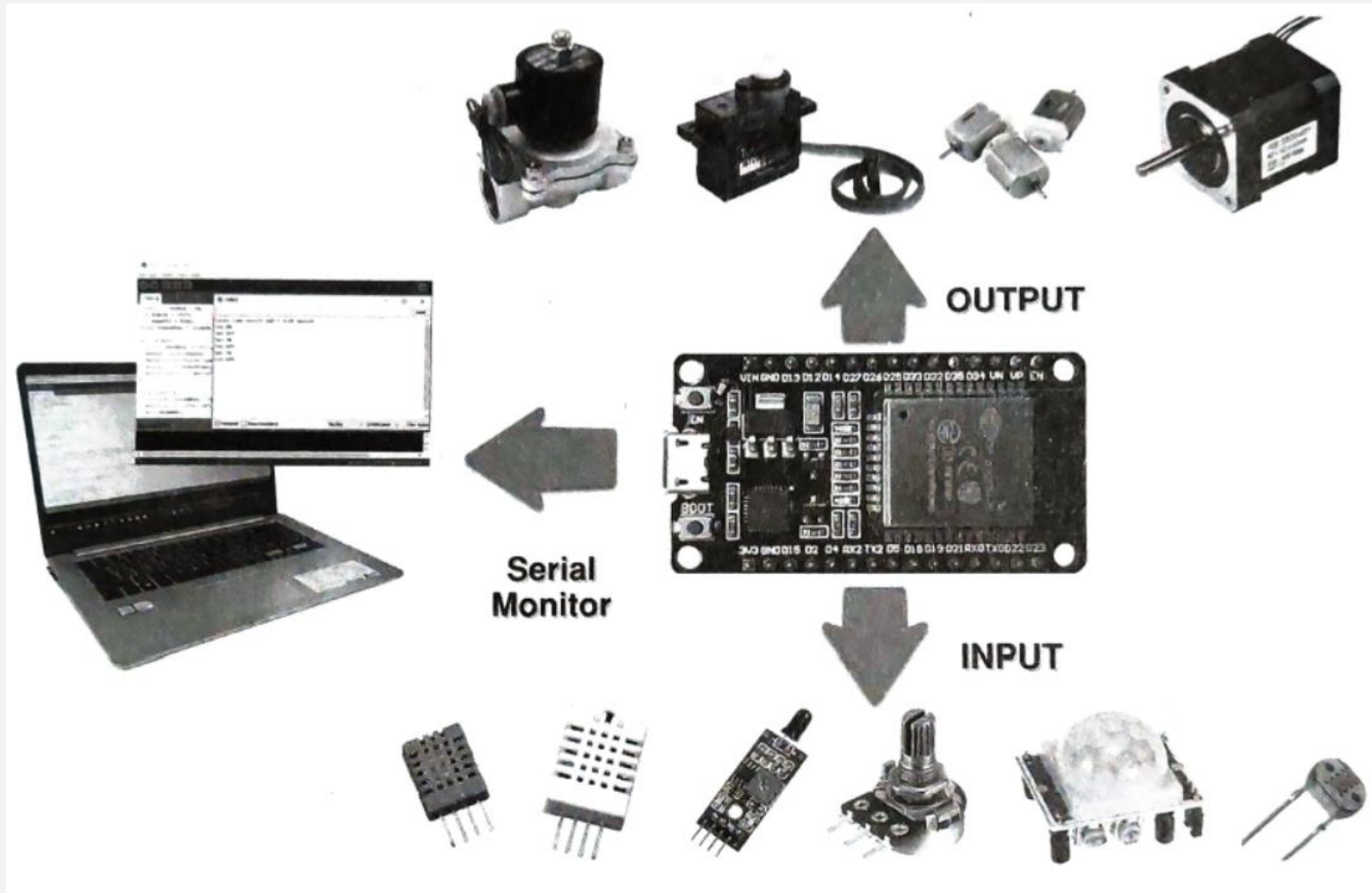

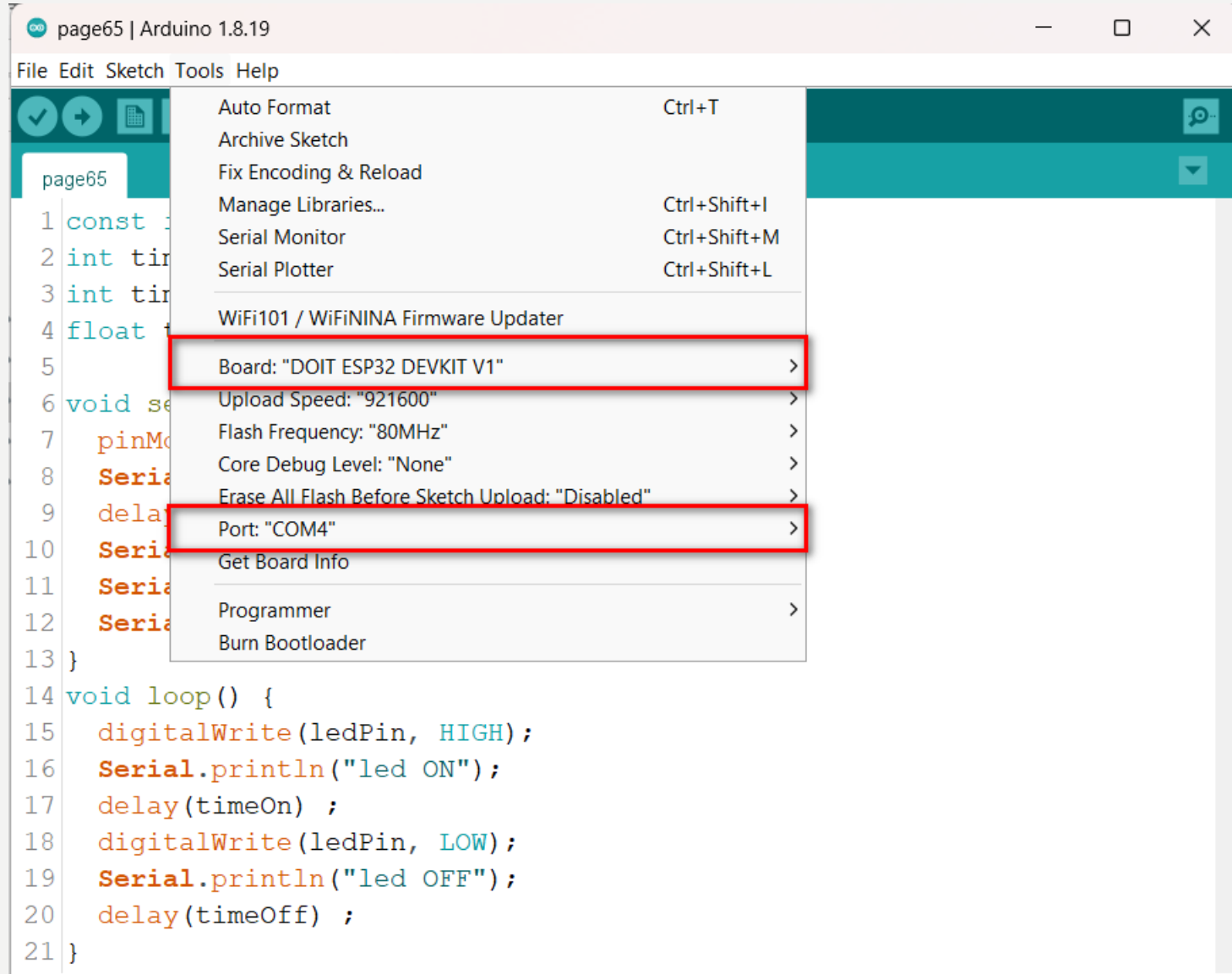

```
page65 | Arduino 1.8.19
File Edit Sketch Tools Help
page65 $
1 const int ledPin = 2;
2 int timeOn = 1500;
3 int timeOff = 2000;
4 float totalTime = (timeOn + timeOff) / 1000;
5
6 void setup() {
7   pinMode(ledPin, OUTPUT);
8   Serial.begin(115200);
9   delay(100);
10  Serial.print("Cycle time on/off LED = ");
11  Serial.print(totalTime);
12  Serial.println(" second");
13 }
14 void loop() {
15  digitalWrite(ledPin, HIGH);
16  Serial.println("led ON");
17  delay(timeOn) ;
18  digitalWrite(ledPin, LOW);
19  Serial.println("led OFF");
20  delay(timeOff) ;
21 }
```

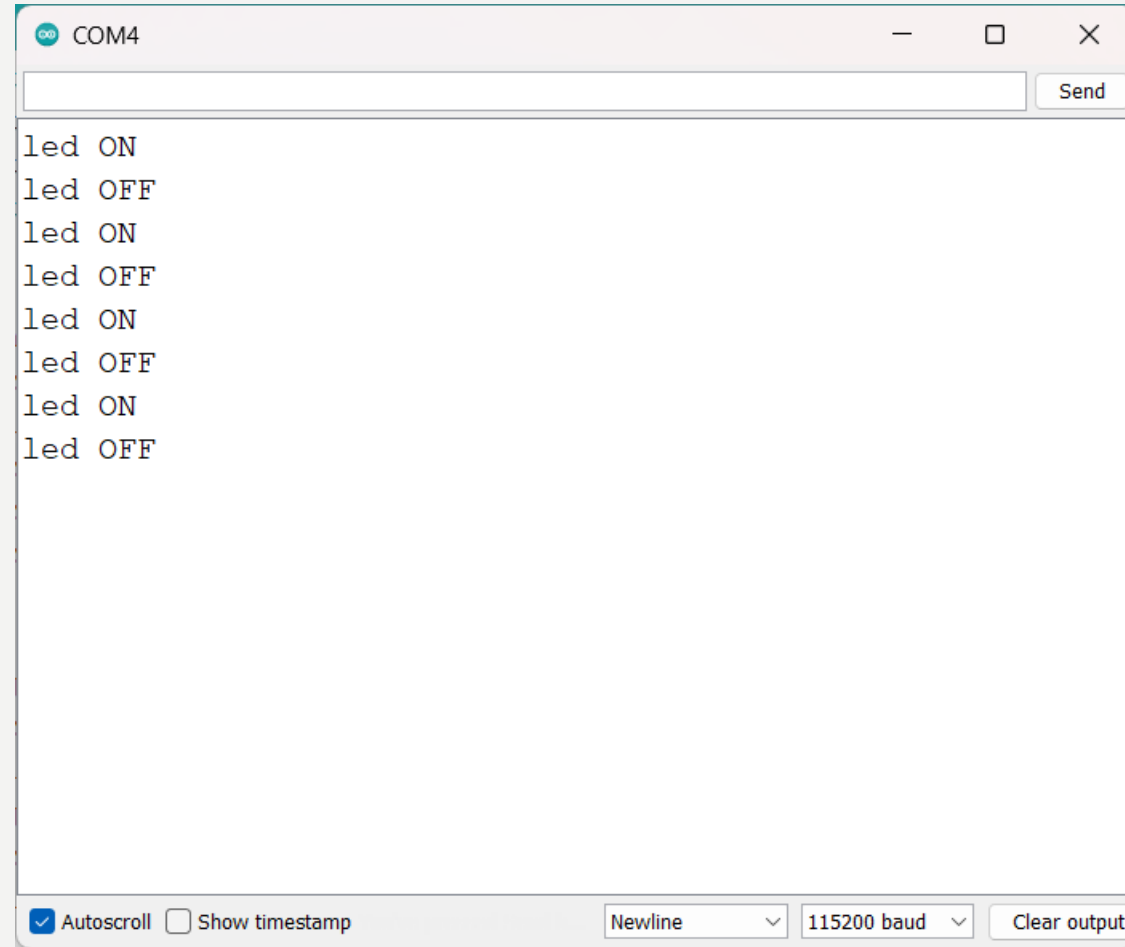

A screenshot of a serial terminal window titled "COM4". The window has a title bar with standard minimize, maximize, and close buttons. Below the title bar is a text input field and a "Send" button. The main area of the window displays a series of text messages: "led ON", "led OFF", "led ON", "led OFF", "led ON", "led OFF", "led ON", and "led OFF". At the bottom of the window, there are several controls: a checked checkbox for "Autoscroll", an unchecked checkbox for "Show timestamp", a dropdown menu set to "Newline", a dropdown menu set to "115200 baud", and a "Clear output" button.

```
COM4
```

led ON
led OFF
led ON
led OFF
led ON
led OFF
led ON
led OFF

Autoscroll Show timestamp Newline 115200 baud Clear output

การใช้ Serial Monitor ส่งข้อมูลจากแป้นพิมพ์ไปยังบอร์ด

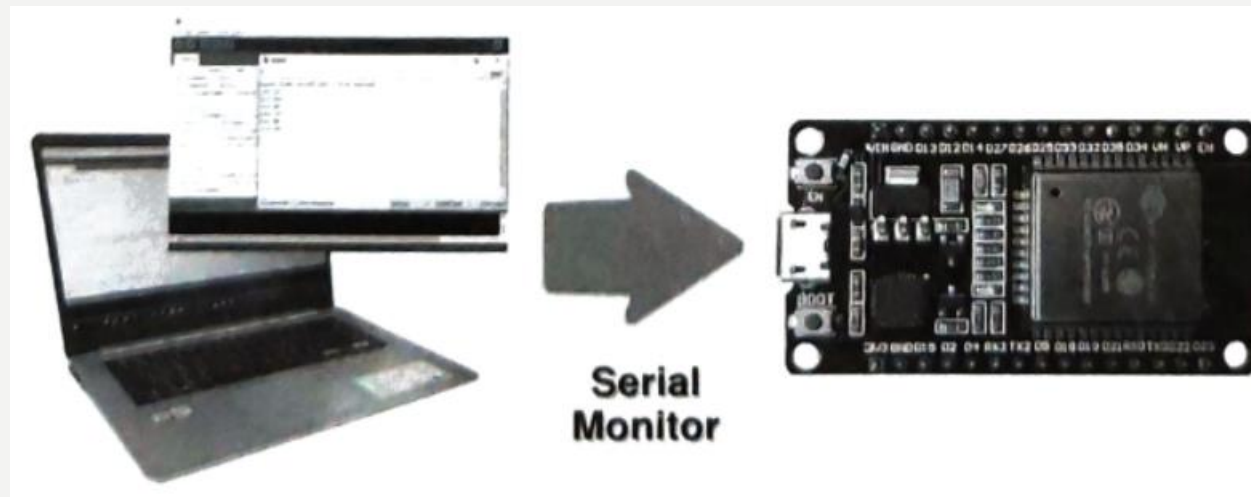

```
page67 | Arduino 1.8.19
File Edit Sketch Tools Help
page67
1 const int ledPin = 2;
2
3 void setup() {
4   pinMode(ledPin, OUTPUT) ;
5   Serial.begin(115200);
6 }
7
8 void loop() {
9   if (Serial.available() > 0) {
10    int inRead = Serial.read();
11    if (inRead == '1') {
12      digitalWrite(ledPin, HIGH) ;
13    } else if (inRead == '0') {
14      digitalWrite(ledPin, LOW) ;
15    } else if (inRead > '1') {
16      Serial.println("Please enter 0 or 1 only");
17    }
18    delay(100);
19  }
20 }
```

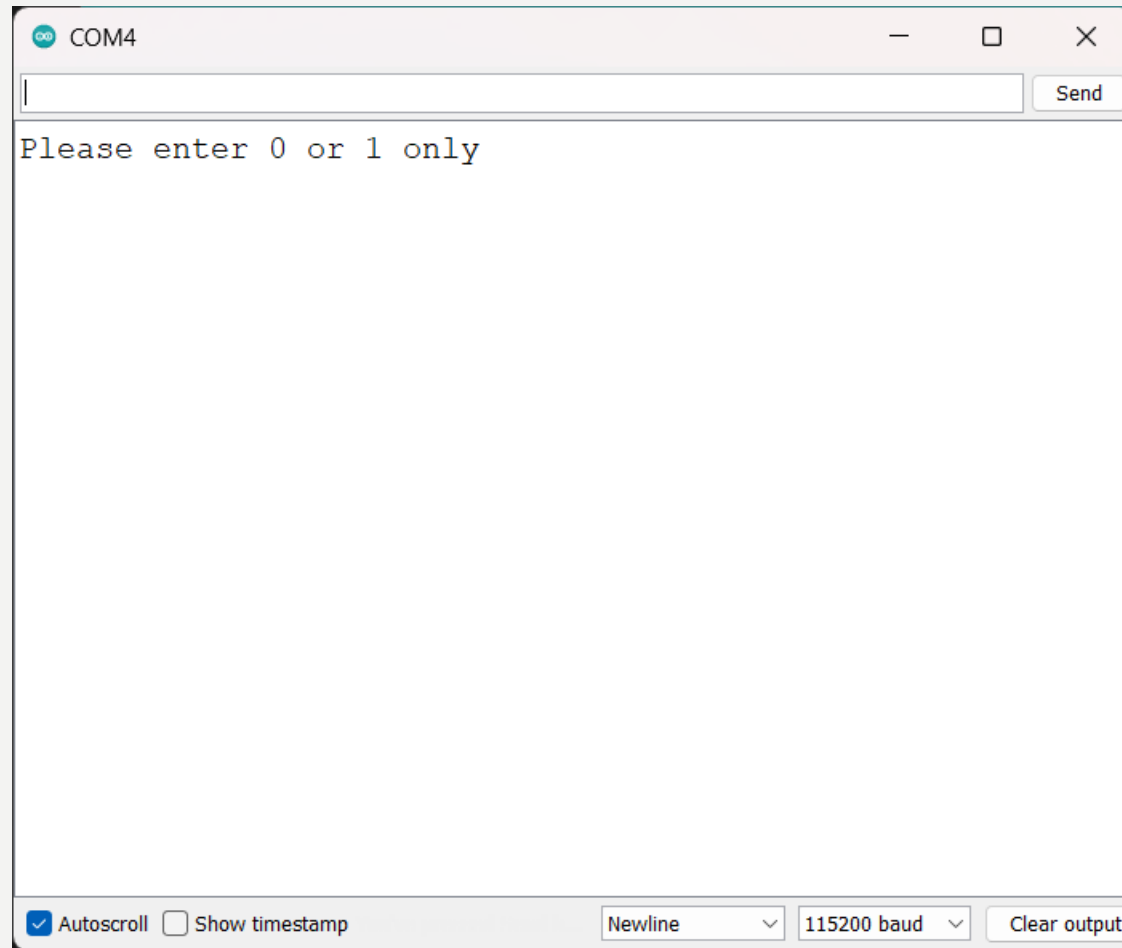

การพล็อตกราฟด้วย Serial Plotter

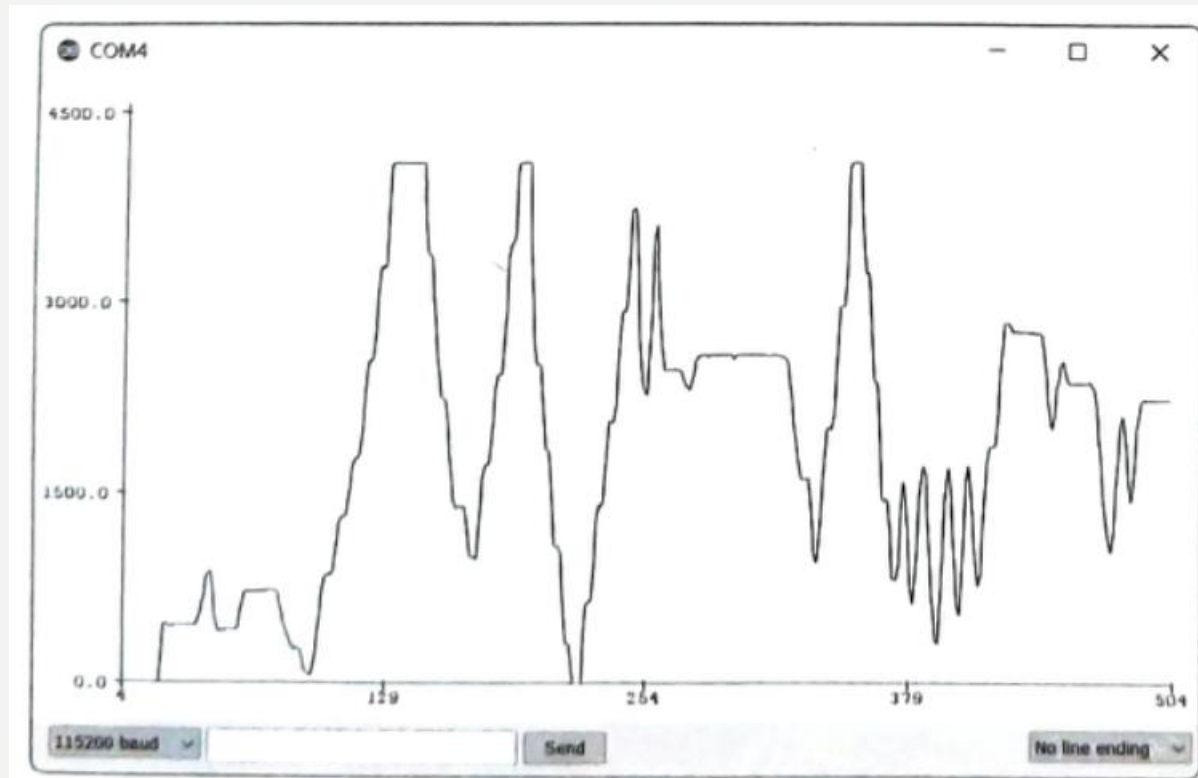

การใช้งาน Serial Plotter

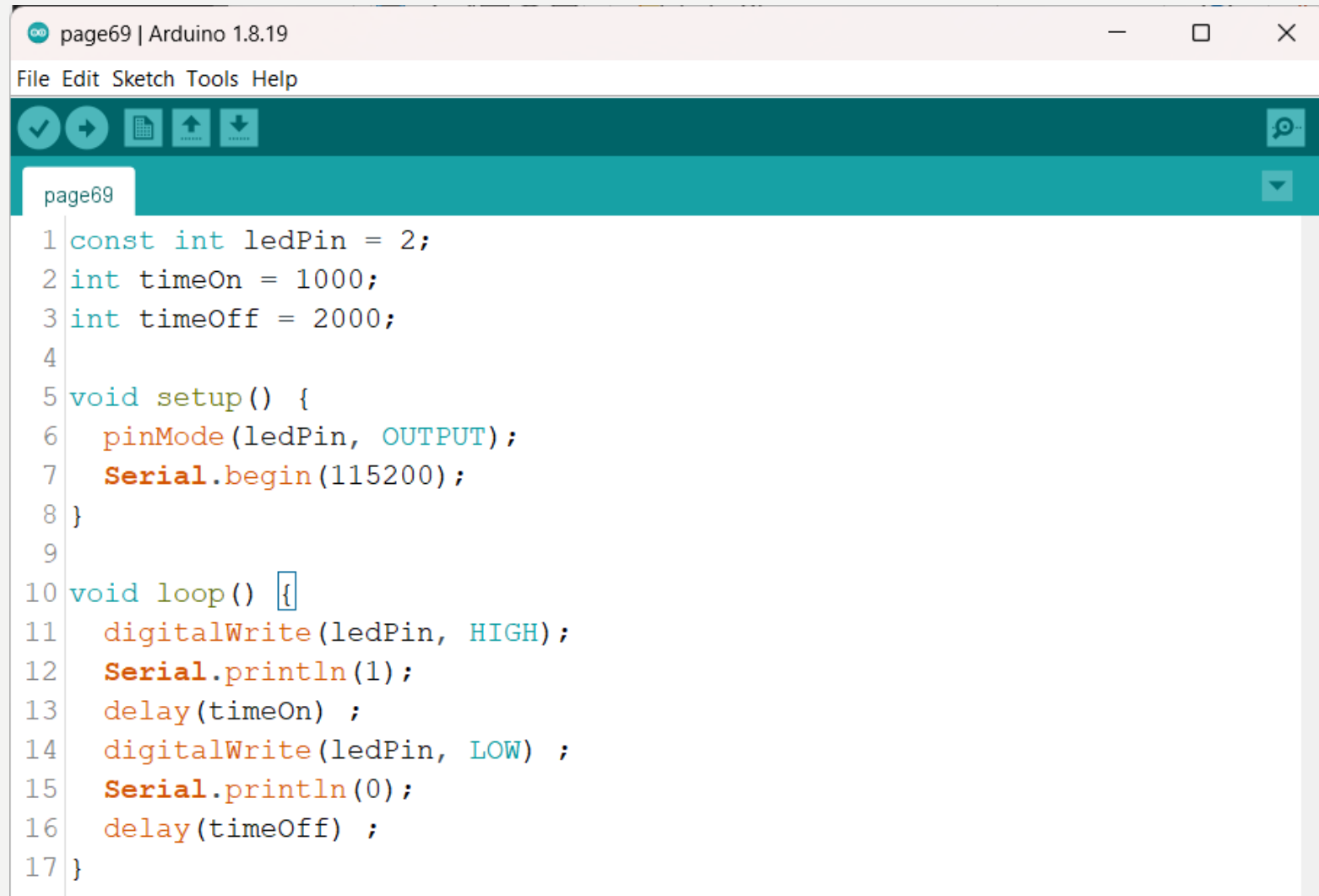

The image shows a screenshot of the Arduino IDE interface. The window title is "page69 | Arduino 1.8.19". The menu bar includes "File", "Edit", "Sketch", "Tools", and "Help". The toolbar contains icons for saving, running, uploading, and downloading. The active tab is labeled "page69". The code editor displays the following C++ code:

```
1 const int ledPin = 2;
2 int timeOn = 1000;
3 int timeOff = 2000;
4
5 void setup() {
6   pinMode(ledPin, OUTPUT);
7   Serial.begin(115200);
8 }
9
10 void loop() {
11   digitalWrite(ledPin, HIGH);
12   Serial.println(1);
13   delay(timeOn) ;
14   digitalWrite(ledPin, LOW) ;
15   Serial.println(0);
16   delay(timeOff) ;
17 }
```