

Battery Management Guide



Charging

Gauging

Protection

Authentication

Monitoring



Battery Management Guide

Introduction and Contents

Texas Instruments (TI) offers a complete battery management portfolio with a full line of high-performance products ranging from battery chargers to highly-efficient battery fuel gauges. Also offered are power protection, authentication, and alternative charging sources such as nano power harvesting and wireless power.

TI makes designing easier with leading-edge design tools and support, a broad selection of evaluation modules (EVMs), application notes, comprehensive technical documentation, and more. Samples and small orders (shipped within 24 hours via TI authorized distributors) help you accelerate your time-to-market.

Included in this selection guide you will find design factors, featured products, graphical representations of portfolios and parametric tables.

For more information about battery management products and resources, visit www.ti.com/battery

Table of Contents

Battery Management System Applications

3	Overview
4	Energy Harvesting and Nano Power Solutions
5	Electric Bicycle Solutions
6	Wireless Power Devices
7	Handheld Consumer Medical Equipment
8	Portable Industrial Solutions
9	Automotive Power Solutions

Battery Management Products

10	Battery Chargers
22	Battery Charger Protection
23	Battery Fuel Gauges and Monitors
26	Battery and Peripheral Authentication
27	Battery (Li-Ion) Protection
28	Wireless Power Solutions

Design and Development Tools

32	Resources
----	-----------

Get Longer Running, Healthier Batteries from TI

Innovative Products

Longer run-time and faster, safer charging



- Broadest portfolio
- Longest possible run-time, most accurate battery capacity measurement
- Faster, safer charging eliminates the need to over design or overcompensate

Robust Design Tools

Streamline development cycle



- Evaluation modules, development kits, software, reference designs
- Find the right IC for your application's performance
- Streamlined process means easier implementation and faster time to market

Battery Experts

TI knows batteries



- Decades of design experience at work for you
- Battery chemistry library covers all known battery types
- Battery scientists drive new technologies and devices

Get more out of your battery with TI Battery Management Solutions

Battery Management System Applications

Overview

End applications in wireless, computing, consumer, medical, industrial, and automotive markets continue to expand into the portable space. Battery management solutions from TI help address system protection, cost-effective linear, and highly-efficient switch-mode battery charging. New advances in switch-mode charging increase efficiency and decrease power dissipation, promoting a green environment by wasting less energy. With battery-powered systems demanding increased reliability, TI ensures maximum product safety with chargers that protect batteries from over-voltage and overcurrent conditions.

Battery Chemistry

Lithium Ion (Li-Ion) is the most widely used chemistry family for rechargeable batteries. There are different chemistries in the Li-Ion family with different operating characteristics such as discharge profiles and self-discharge rate. TI battery management devices are developed by chemistry to account for these differences to charge the battery more efficiently and report the remaining energy in the battery more accurately.

Fundamentals

TI products support portable applications such as mobile phones, smartphones, tablets, consumer devices, navigation devices, notebook computers, many medical, industrial, and automotive applications. TI has a battery management device to match your design specifications. We also offer the evaluation modules, application notes, samples and data sheets needed to get your design to market faster.

Portable Power system Diagram

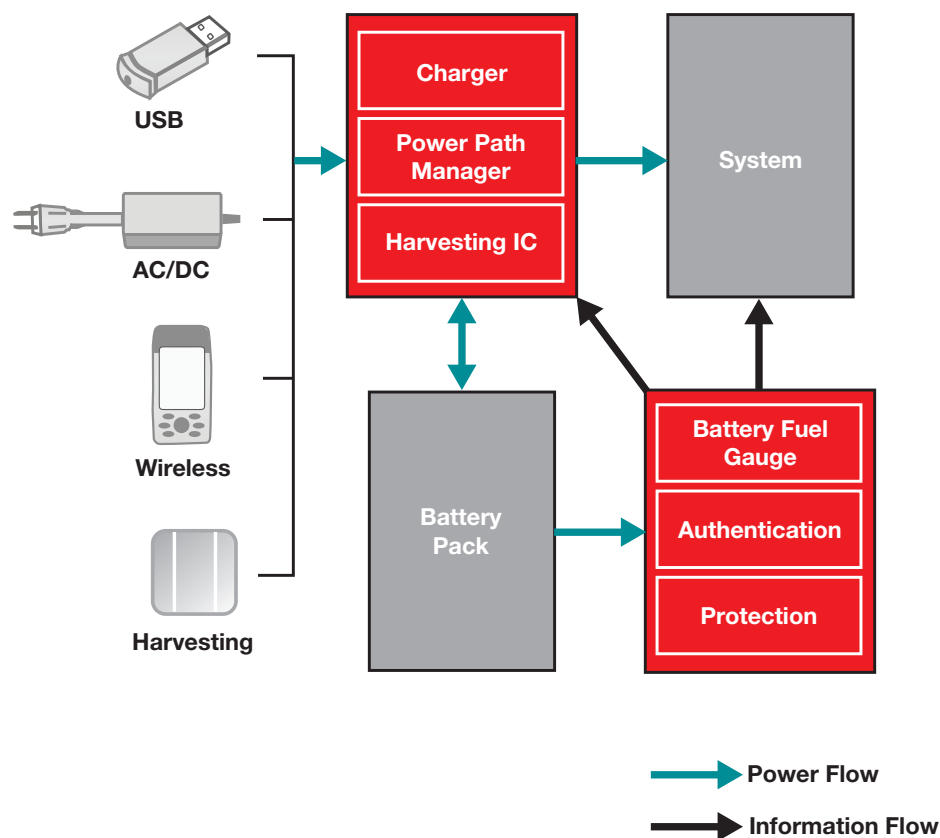

Battery Management System Applications

Energy Harvesting and Nano Power Solutions

Design Factors

Harvester Element — The type of element used for energy harvesting depends on the power requirements of the load. The energy capable of being harvested varies according to the element selection. TI's energy harvesting solutions can interface to a variety of harvesters such as solar (PV) cells, thermo-electric generators (TEGs) and piezo devices.

Storage Element — Energy that is harvested is usually stored for later use in periods of "dark time" when harvesting

may not be possible due to insufficient ambient energy. TI's energy harvesting solutions are capable of storing energy in different types of storage elements such as Li-Ion rechargeable cells, super-caps, conventional caps and thin-film batteries (solid-state batteries).

Ultra-Low-Power Conversion Unit — The low-level input delivered by a harvester element needs to be converted to a usable level for downstream microelectronics and the power-conversion solution must be very efficient. TI's energy harvesting solutions

have the industry's lowest active current requirements, thus allowing most of the harvested energy to be transferred to the load.

Activity Level — Energy harvesting systems spend most of their time in sleep state; waking up periodically to take and report measurements, then going back to sleep until it is time for the next measurement. The power consumed in the sleep state is very critical for extended and reliable operation to prevent premature shutdown.

Typical Application

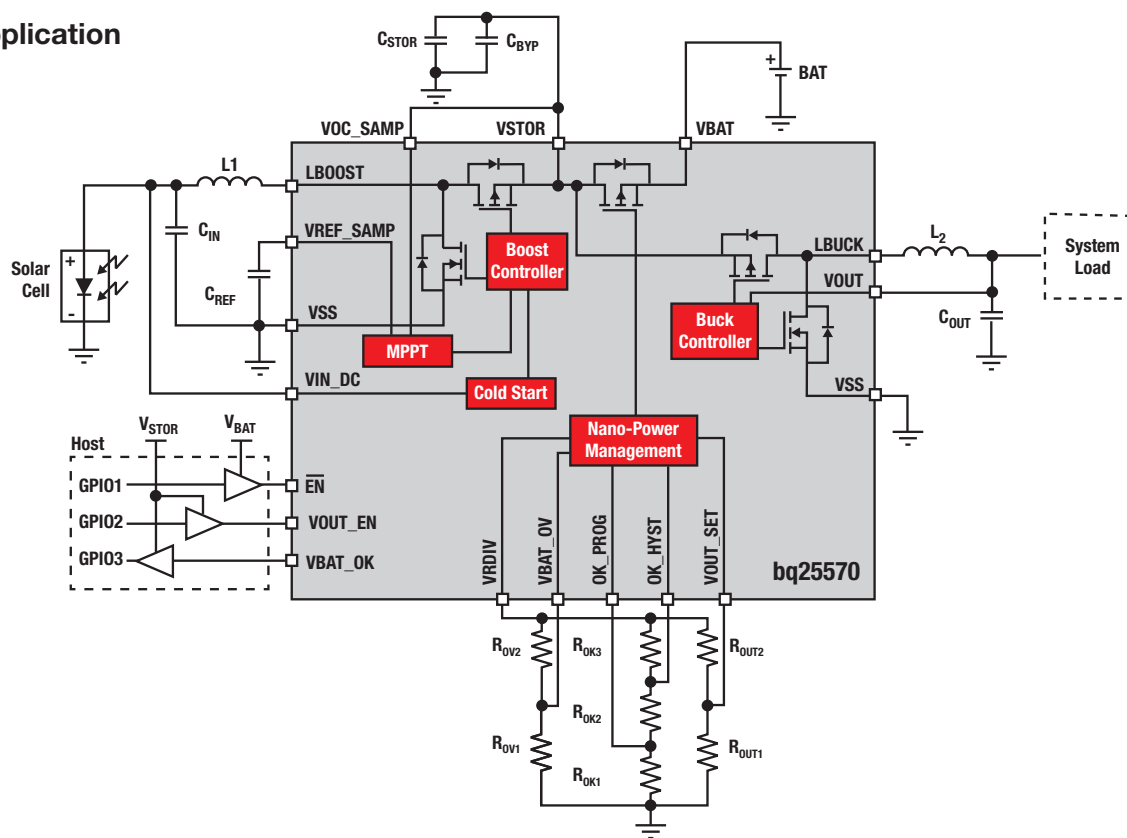

Get more information: www.ti.com/product/bq25570

Featured Energy-Harvesting Devices

Device	Description
bq25505	Ultra-low-power boost converter with battery management and autonomous power-path multiplexing
bq25504	Ultra-low-power boost converter with battery management
bq25570	Ultra-low-power boost converter with battery management and buck output regulation
TPS62736/37	Ultra-low I_Q nano-buck regulators
bq25504EVM-674	Evaluation module for bq25504 ultra-low-power boost converter
TPS62736EVM-205	Evaluation module for TPS62736 programmable-output, ultra-low-power buck converter

New products are listed in bold red.

Battery Management System Applications

Electric Bicycle Solutions

In many parts of the world, electric bicycles (e-bikes) offer a convenient and affordable alternative to the automobile or public transportation. Compared to traditional, purely mechanical bicycles, e-bikes provide motor assistance for riders to conquer tough uphill inclines and render a daily commute nearly effortless.

Today, roughly 150 million e-bikes are already on the road and this number is projected to double in less than half a decade. In Asia, the majority of current and older generation models still employ a lead acid battery, while those sold in Europe use Lithium-Ion chemistry. With the price between the two reigning chemistries converging, the future development trend for e-bikes is in favor of Lithium-Ion, which offers several tangible benefits for the typical bicycle owner.

Features

- Higher gravimetric and volumetric density translates to smaller and lighter battery packs that can be easily removed for charging
- Extended cycle life for reliable operation of three years and beyond
- Eco-friendly with far less toxicity than lead acid

A typical e-bike system includes three core components — a battery pack, motor drive unit and user display.

- **Battery pack** — Integrates all electronics needed for safe charging and discharging and may include more sophisticated electronics to calculate things such as remaining capacity and battery health.

- **Motor drive unit** — Powered by the battery, a complex mix of sensors and a motor controller that provides torque assistance while the bike is in operation. Some high-end solutions also offer features such as regenerative braking, electronic gearshift and maximum speed limiting.

- **User display** — Serves as the primary interface to the rider and provides up-to-date information on the bicycle. Displays metrics such as remaining distance, motor power output and battery condition.

Typical Application

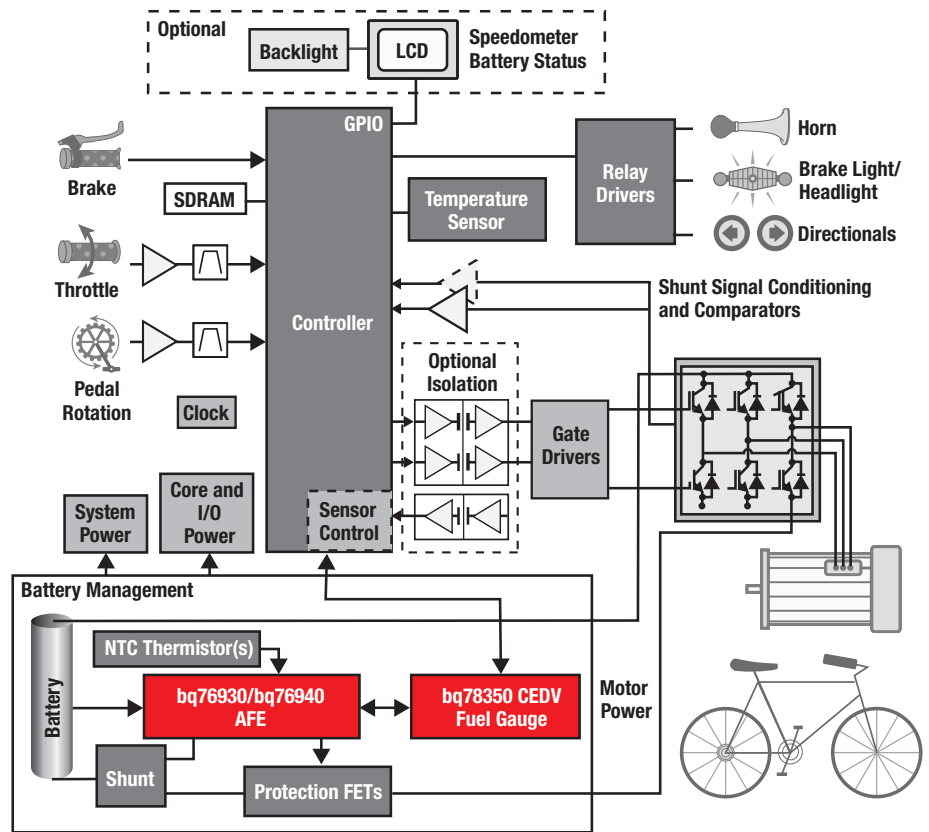

Featured E-Bike Devices

Device	Description
bq76930	6-10S next-generation analog front-end with digital I ² C interface, integrated ADCs and hardware protection
bq76940	9-15S next-generation analog front-end with digital I ² C interface, integrated ADCs and hardware protection
bq78350	CEDV fuel gauging battery manager with configurable protection, lifetime data logging, cell balancing and SMBus interface and LED display. Pair with bq76920/bq76930/bq76940

Device	Description
bq34z110	Pack-based Impedance Track™ fuel gauge for lead acid
bq77PL900	18-V, 24-V and 36-V (5-10S) dual-mode, analog front-end and standalone voltage, current and temperature pack protector
bq771800	5S secondary overvoltage protector
bq771600	4S secondary overvoltage protector

New devices are listed in bold red.

Battery Management System Applications

Wireless Power Devices

A wireless power system consists of a transmitter (charging pad) and a receiver (mobile device). Both contain a coil and electronics. Power is transferred wirelessly between the coils via inductive coupling. These systems are typically used for charging batteries in mobile devices, or powering subsystems.

Applications

- Smartphones
- Accessory chargers
- Digital cameras
- Bluetooth® headsets
- Tablet computers
- Portable industrial devices
- Portable and wearable equipment for medical, health and fitness applications
- In-car charging systems
- Speakers

Typical features included with RX and TX devices are compliant to WPC v1.1 specification, foreign-object detection (FOD), 5-V, 12-V, or 19-V support for transmitter power, 5-V, 7-V or adjustable receiver output options, and automatic adapter detection. A built-in Li-Ion charge controller is also included in some of the receiver devices.

Typical Application

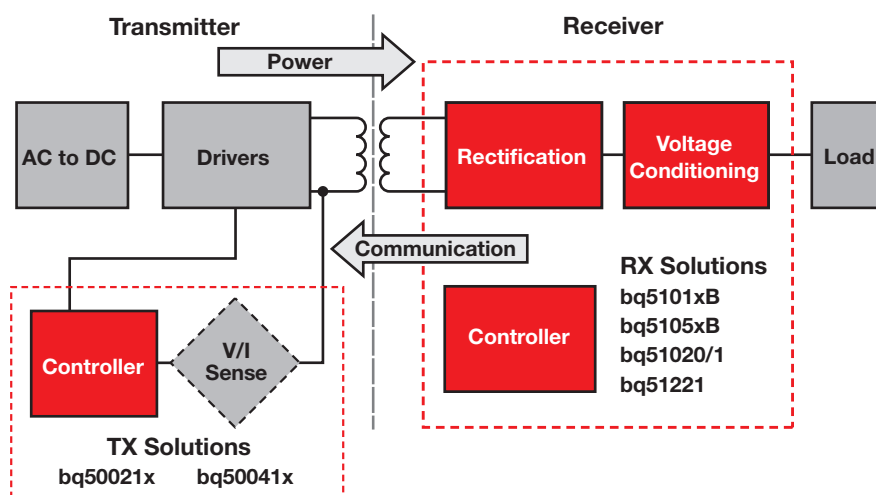

Featured Wireless Power Devices

Device	Description
bq51003	2.5-W highly integrated wireless-receiver Qi-compliant (WPC v1.1) power supply
bq51013B	5-W Qi-compliant, fully-integrated wireless-power receiver device
bq51010B	5-W highly-integrated wireless receiver, Qi-compliant power supply
bq51020	Qi-compliant high-efficiency, 5-W receiver with adjustable output voltage
bq51021	Qi-compliant high-efficiency, 5-W receiver with adjustable output voltage and I ² C control
bq51050B	4.2-V Qi-compliant, highly-integrated, secondary-side, direct Lithium-Ion charger
bq51051B	4.35-V integrated wireless power, Li-Ion-charger receiver, Qi-compliant
bq51221	Dual-mode, WPC v1.1/PMA high-efficiency receiver with adjustable output voltage I ² C control
bq500210	WPC v1.0 transmitter solution for 19-V _N systems
bq500212A	Latest WPC v1.1, 5-V transmitter with reduced BOM and improved, simplified FOD
bq500412A	Latest WPC v1.1, 12-V transmitter with reduced BOM and improved, simplified FOD
bq500414Q	AEC-Q100-qualified, A6 transmitter for automotive applications
bq51025	10-W WPC v1.1-compliant single-chip wireless power receiver
bq500215	Fixed frequency 10-W WPC v1.1 wireless power transmitter

New products are listed in bold red.

Get more information: www.ti.com/wirelesspower

Battery Management System Applications

Handheld Consumer Medical Equipment

Rechargeable Li-Ion batteries are becoming common place in consumer medical devices where extended battery life is a key requirement. Features such as additional memory, audio feedback and wireless connectivity drive the need for higher power, which means higher battery capacities. Many applications are now available as portable devices.

Applications

- Blood glucose meters
- Digital blood pressure meters
- Digital thermometers
- Digital pulse/heart rate monitors
- Blood cholesterol meters
- Portable and wearable equipment for medical, health and fitness applications

Li-Ion charge controllers and fuel gauges have become key components in these systems. Typical features included on these power management devices include power-path support, USB and AC adapter support, wide input-voltage capability, battery-status outputs, cell balancing and battery-capacity tracking.

Typical Application

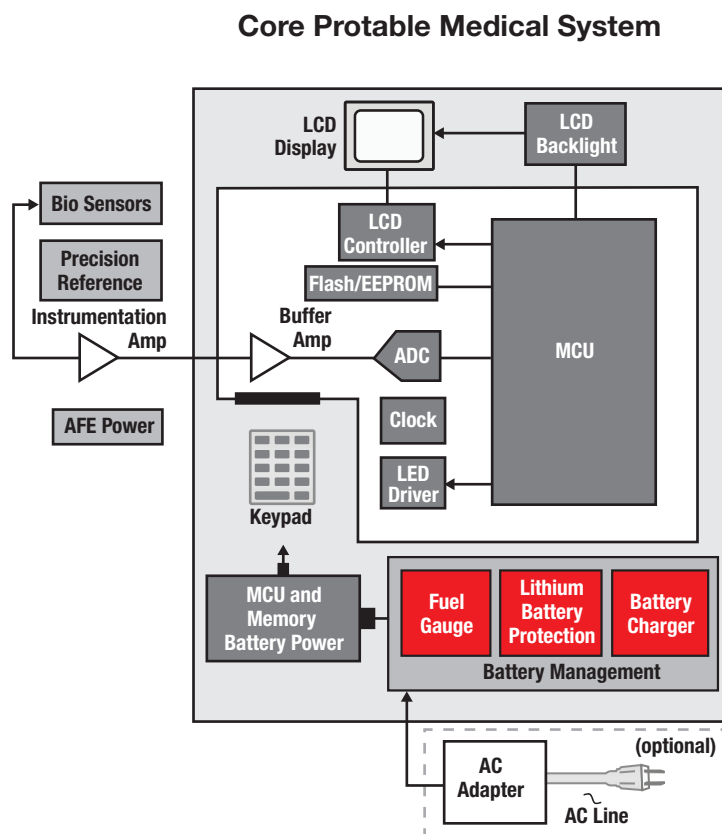

Featured Medical Equipment Devices

Device	Description
bq24040/45	1-A, single-input, single-cell Li-Ion battery charger with auto start
bq24250	2-A, single-input, I ² C/standalone, switch-mode Li-Ion battery charger
bq24253	2-A, single-input, I ² C/standalone, switch-mode Li-Ion battery charger
bq51050B	Qi-compliant, wireless-power, secondary-side, direct Li-Ion charger
bq500212A	Qi-compliant, 5-V wireless-power transmitter manager
bq27541	Single-cell, Li-Ion-battery fuel gauge for battery-pack integration
bq27742	Single-cell, Li-Ion-battery fuel gauge with integrated protection
bq24314A/C	Overvoltage and overcurrent protection IC with Li+ charger front-end protection
bq24133	Synchronous switch-mode Li-Ion and Li-Polymer stand-alone battery charger
bq24610	Stand-alone synchronous switch-mode Li-Ion or Li-Polymer battery charger with 5-V to 28-V V _{CC} input

Battery Management System Applications

Portable Industrial Solutions

The increasing need to harness renewable power sources such as photovoltaic and wind energy, coupled with the proliferation of cloud data services, have led to a surge of interest in industrial energy storage systems (ESS). Some ESS are optimized for extended runtime. For

example, a home off-grid PV-to-battery system where solar energy charges a battery during daylight hours, which in turn is used at night.

Others applications are geared towards high-rate brief discharges, such as data center backup during emergency-system

power loss. From simple protectors and analog front ends (AFEs) to sophisticated pack-management controllers and fuel gauges, TI's industrial battery management solutions are designed to maximize scalability across the full spectrum of ESS application requirements.

Intelligent Pack with Monitoring Application

The bq76920/bq76930/bq76940 AFE family offers a modular approach to pack management, with built-in ADCs and a fully digital interface to any host microcontroller.

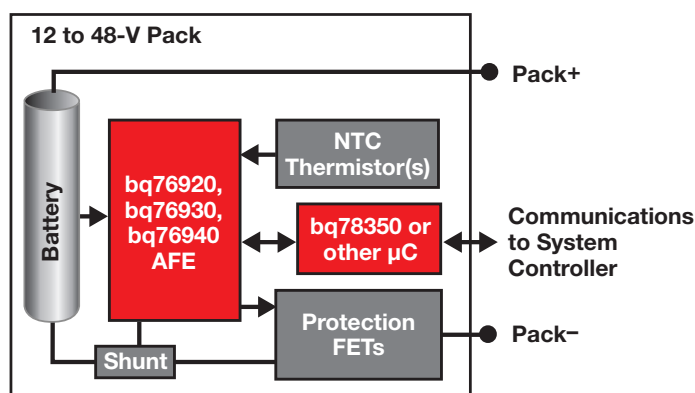

Key Features

- Handles up to 48-V modules; large systems may be built by stacking modules
- Measures cell voltage, temperature and integrated pack current
- Built-in overvoltage, undervoltage, overcurrent and short-circuit protection
- Output LDO in either 2.5-V or 3.3-V options
- Pairs with optional MCU for fuel gauging
- I²C communication to MCU

Featured Industrial Power Devices

Device	Description
bq76920	3-5S next-generation analog front-end with digital I ² C interface, integrated ADCs and hardware protection
bq76930	6-10S next-generation analog front-end with digital I ² C interface, integrated ADCs and hardware protection
bq76940	9-15S next-generation analog front-end with digital I ² C interface, integrated ADCs and hardware protection
bq78350	Companion CEDV fuel-gauge battery manager with LED driver for bq76940, bq76930 and bq76920
bq76925	3-6S analog front-end with analog output and hardware short circuit detection
bq76PL536A	3-6S stackable analog front-end with integrated precision ADC and SPI interface

Device	Description
bq24133	Synchronous switch-mode Li-Ion and Li-Polymer stand-alone battery charger
bq24610	Stand-alone synchronous switch-mode Li-Ion or Li-Polymer battery charger with 5-V to 28-V V _{CC} input
bq34z110	Pack-based Impedance Track™ fuel gauge for lead acid
bq77PL900	18-V, 24-V and 36-V (5-10S) dual-mode analog front end and standalone voltage, current and temperature pack protector
bq771800	5S secondary overvoltage protector
bq771600	4S secondary overvoltage protector

New products are listed in bold red.

Battery Management System Applications

Automotive Power Solutions

TI's battery management devices for electric, hybrid and plug-in-hybrid vehicles are designed to provide high accuracy, communication robustness and hot-plug performance. Products such as the bq76PL536A-Q1 integrated protector help minimize board space and component count.

The bq76PL536A-Q1 is good design choice for monitoring voltage, temperature and other sensors in applications that use a large-capacity battery.

Key Features

- 3- to 6-series cell support for all chemistries
- Stackable vertical interface
- Hot-pluggable
- No isolation components required between devices
- Qualified for automotive applications
- Temperature range -40°C to 105°C
- High accuracy (± 1 mV typical)
- Two temperature inputs and one general-purpose input
- Built-in comparators (secondary protector) for:
 - Over and undervoltage protection
 - Overtemperature protection
- Low power

Typical Application

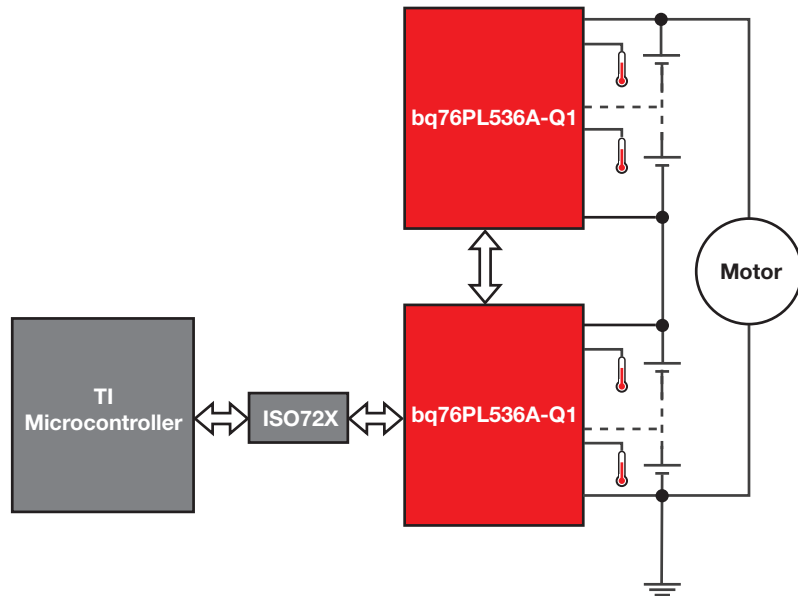

bq76PL536A Accuracy Rating vs. Temperature

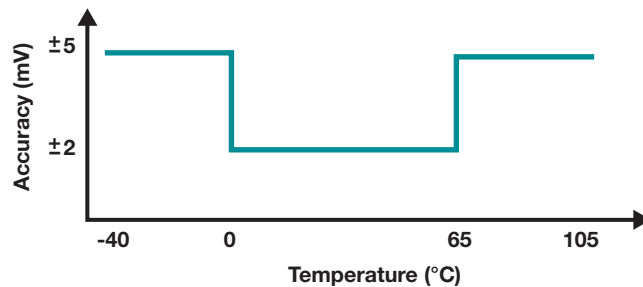

Featured Automotive Power Devices

Device	Description
bq76PL536A-Q1	3- to 6-series cell Lithium-Ion battery monitor and secondary protection IC for EV and HEV applications
EMB1428Q	Active-balancing, switch-matrix gate driver
EMB1499Q	Active-balancing, bidirectional current DC/DC controller

Battery Management Products

Battery Chargers

Design Factors

Battery Chemistry — Each battery chemistry has different operating characteristics, such as discharge profiles and self-discharge rate. TI gas-gauge devices are developed to account for these differences and accurately display remaining energy in the battery. Each battery chemistry has unique requirements for its charge algorithm, which is critical for maximizing its capacity, cycle life and safety.

Charge-Control Topology — A simple linear topology works well in applications

with low-power (e.g., one- or two-cell Li-Ion) battery packs that are charged at less than 1 A. A switch-mode topology is well-suited for fast charging from USB ports or for large battery packs that require charge rates >1 A. The switch-mode conversion minimizes heat generation during charging. A wireless power topology uses shared magnetic fields to provide the benefit of contactless power transfer. Wireless charging provides an additional battery-charging option for portable devices or as a replacement for other 5-V charging sources.

Input Voltage — Wide input-voltage range of the device and input overvoltage protection offer maximum safety and allow use of low-cost unregulated wall adapters.

Number of Series Cells — A battery pack is constructed from a string of series and parallel cells. Each series cell, or group of parallel cells, requires protection from overcharge, overdischarge and short-circuit conditions.

Battery Chargers

Purpose

- Correctly charge using constant current and voltage
- Maximize battery life and capacity
- Maintain safe operating range for voltage, current and temperature

What type of power source is available to recharge your battery pack?

- **High-Voltage AC Power** — The first stage of the battery-charging circuit requires an isolated power converter to generate a lower-voltage DC rail that is used to charge the battery pack.
- **Mid-Voltage DC Power** (~12 to 30 VDC) — A switch-mode charger will be the likely charge-control solution. For higher currents (above 4 A), external power FETs will likely be required. For currents below 4 A, in many cases a fully integrated solution may be possible.
- **Low-Voltage DC** (e.g., from adapter or USB port) — A low-cost linear charger may be usable for currents below 1 A. Low-voltage switch-mode chargers are recommended for currents above 1 A.

If the application requires simultaneous battery charging and system operation, the charger device should include power-path control functionality.

Single-Cell Li-Ion Charger Quick Reference

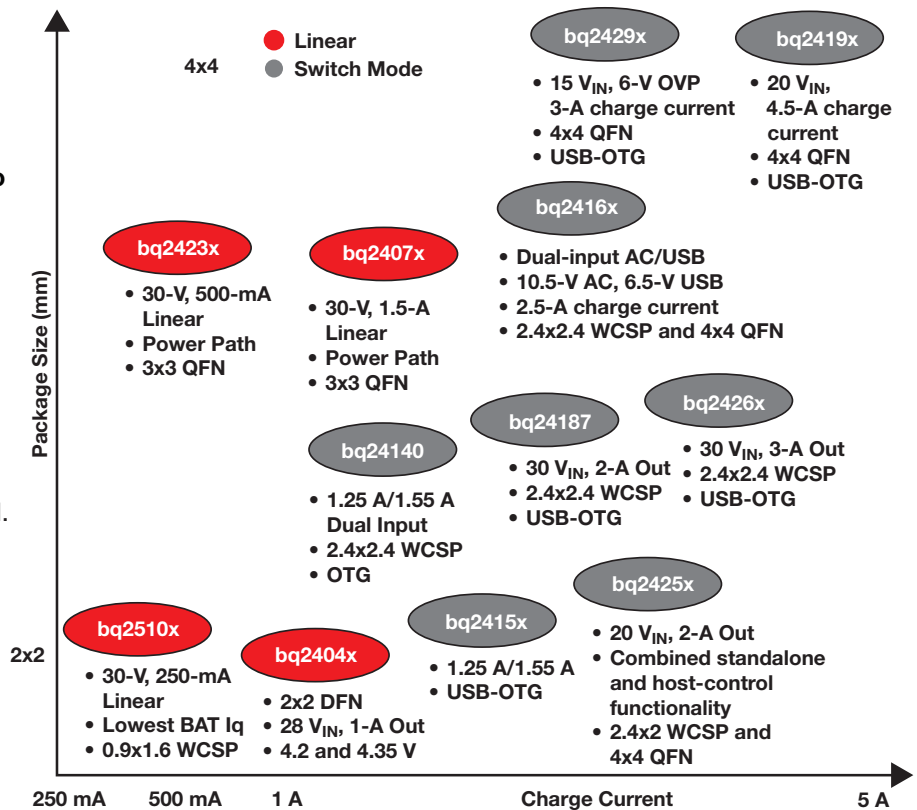

Battery Management Products

Battery Chargers

Ultra-Small 250-mA Linear Charger in 0.9mm x 1.6mm WCSP

bq2510x

The bq2510x family is the new 250-mA linear charger designed for low-current applications such as wearables. The bq2510x holds the industries' lowest I_q (quiescent current) at only 75 nA max. The bq2510x features a more accurate charge current control (down to 10 mA), which makes it ideal for small-capacity battery. This family comes in an ultra-small 0.9 x 1.6mm WCSP package.



Qi (WPC) Compliant Wireless Charger for Low Power Wearable Application
www.ti.com/tool/TIDA-00318

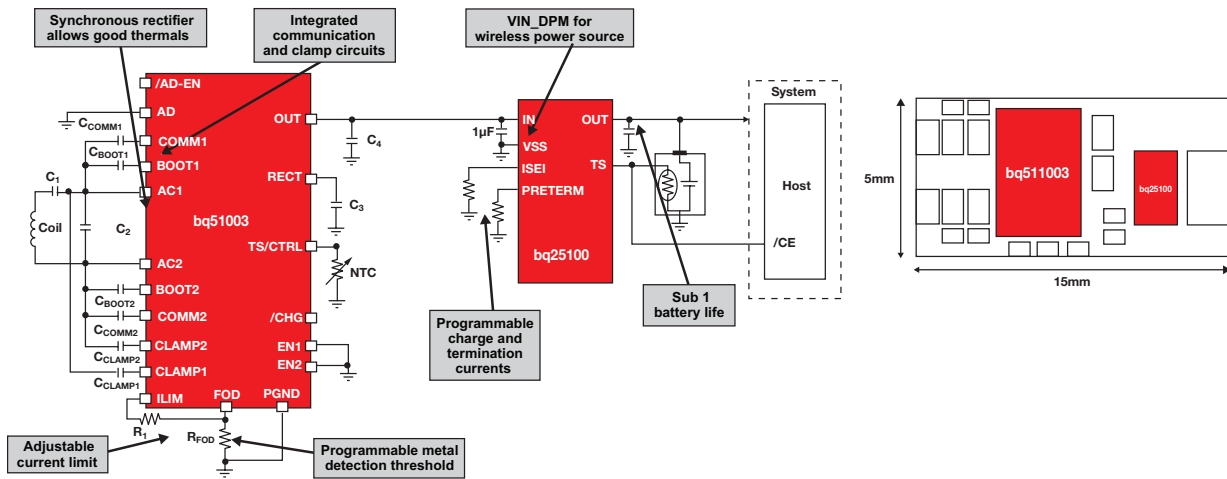

Device	VBATREG	ICHG	BAT Leakage	OVP	Min Term	Charge LED Driver	TS	WCSP	Size
bq25100	4.2 V	250 mA	50 nA	6.5 V	1 mA	No	JEITA	6 balls	0.9mm x1.6mm
bq25100A	4.3 V	250 mA	50 nA	6.5 V	1 mA	No	JEITA	6 balls	0.9mm x1.6mm
bq25100H	4.35 V	250 mA	50 nA	6.5 V	1 mA	No	JEITA	6 balls	0.9mm x1.6mm
bq25101	4.2 V	250 mA	50 nA	6.5 V	1 mA	Yes	JEITA	6 balls	0.9mm x1.6mm

Get more information: www.ti.com/product/bq25100

Ultra-Low-Power, Harvester PMIC with Boost Charger and Autonomous Power Multiplexor

bq25505

The bq25505 is the first of a new family of intelligent integrated energy-harvesting, nano-power management solutions that are well suited for meeting the special needs of ultra-low-power applications. The product is specifically designed to efficiently acquire and manage the microwatts (µW) to milliwatts (mW) of power generated from a variety of DC sources like photovoltaic (solar) or thermal electric generators (TEGs).

Key Features

- Cold-start voltage: $V_{IN} \geq 330$ mV
- Continuous energy harvesting from input sources as low as 100 mV
- Ultra-low quiescent current: 320 nA
- Energy can be stored to rechargeable Li-Ion batteries, thin-film batteries, super capacitors or conventional capacitors
- Programmable maximum power point tracking (MPPT)

Applications

- Energy harvesting, solar charger, thermal electric generator (TEG)
- Wireless sensor networks (WSN)

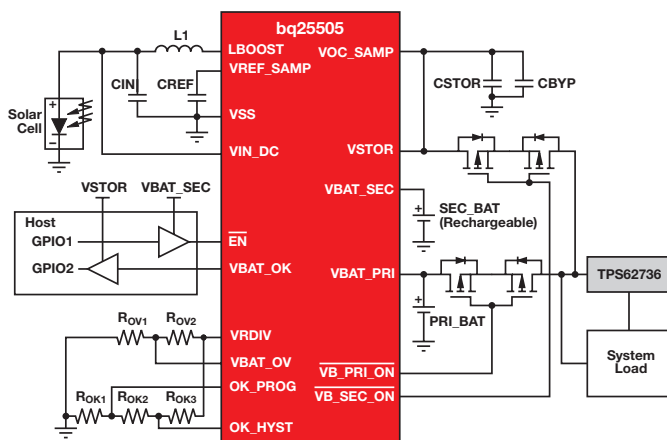

Get more information: www.ti.com/product/bq25505

Battery Management Products

Battery Chargers

2.5-A, Dual-Input, Switch-Mode Charger with Power-Path Management and Host I²C Control or Stand Alone

bq2416x Family

The bq2416x family of highly integrated, single-cell, Li-Ion battery chargers include system power-path management. They are targeted for space-limited, portable applications with high-capacity batteries.

Key Features

- Start-up system from deeply discharged battery or no battery
- Sync 1.5-MHz PWM switch mode
- Supports USB 2.0 and USB 3.0 charger applications
- 20-V max V_{IN} rating
- Integrated FETs with 2.5-A charging from V_{IN} and 1.5 A on USB input
- Integrated power path and driver for optional external discharge FET
- Integrated input current sensing and limiting (±5%)
- Dual inputs are fully isolated

- Control charge parameters, timers, V_{INDPM} threshold
- Thermal regulation protection for output current control
- 2.8x2.8-mm WCSP and 4x4-mm QFN package options

Applications

- Handheld portable products
- Portable computing
- Portable media players
- DSC and DVR equipment

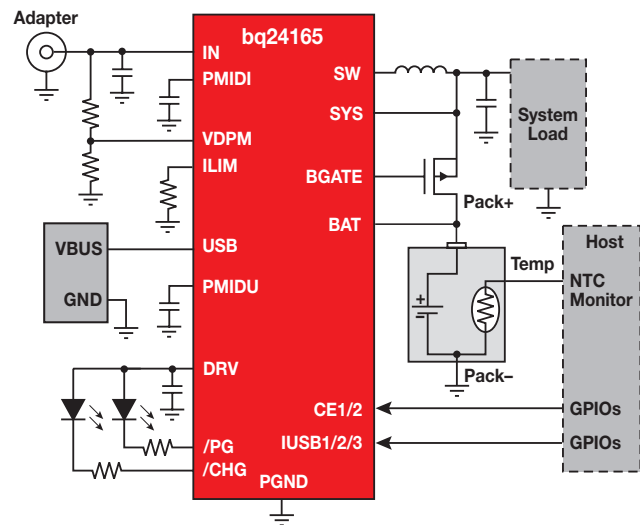
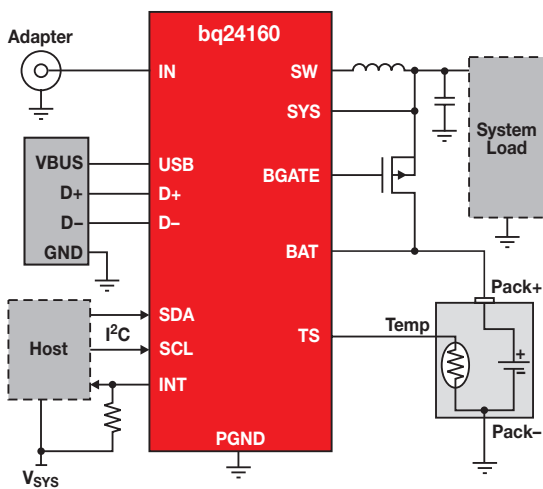

Get more information: www.ti.com/product/bq24160 or [bq24165](http://www.ti.com/product/bq24165)

Single-Cell Chargers Selection Guide

Device	Number of Cells	V _{IN} OVP (V)	Charge Current (A)	Charge Voltage (V)	Topology	Internal FET	Temp Monitor	WCSP	QFN	EVM	USB Detection	Price*
Host Mode with I²C System Interface												
bq24160/A	1	10.5/6.5 (USB)	2.5/1.5 (USB)	3.5 to 4.4	Switching	Yes	Yes, JEITA	49	24	✓	D+/D-	1.95
bq24161/B	1	10.5/6.5 (USB)	2.5/1.5 (USB)	3.5 to 4.4	Switching	Yes	Yes, Std	49	—	✓	PSEL	1.95
bq24163	1	10.5/6.5 (USB)	2.5/1.5 (USB)	3.5 to 4.4	Switching	Yes	Yes, JEITA	49	24	✓	D+/D-	1.95
bq24168	1	6.5/6.5 (USB)	2.5/1.5 (USB)	3.5 to 4.4	Switching	Yes	Yes, JEITA	49	24	✓	PSEL	1.95
Stand Alone System Interface												
bq24165	1	10.5/6.5 (USB)	2.5/1.5 (USB)	4.2	Switching	Yes	via Host JEITA Adj CE1/2	49	24	✓	I _{USB1/2/3}	1.95
bq24166	1	10.5/6.5 (USB)	2.5/1.5 (USB)	4.2	Switching	Yes	Yes/Std	49	24	✓	I _{USB1/2/3}	1.95
bq24167	1	10.5/6.5 (USB)	2.5/1.5 (USB)	4.2	Switching	Yes	via Host JEITA Adj CE1/2	49	24	✓	I _{USB1/2/3}	1.95

*Suggested resale price in U.S. dollars in quantities of 1,000.

Battery Management Products

Battery Chargers

High-Current, High-Efficiency, Narrow-VDC Chargers for Single-Cell Li-Ion with Power-Path Management and USB OTG

bq2419x, bq2429x Families

The bq2419x/29x families of fully integrated single-cell 4.5/3-A NVDC-1 chargers feature power-path management. These devices achieve fast charging, USB detection, and high USB on-the-go (OTG) efficiency with small overall solution size.

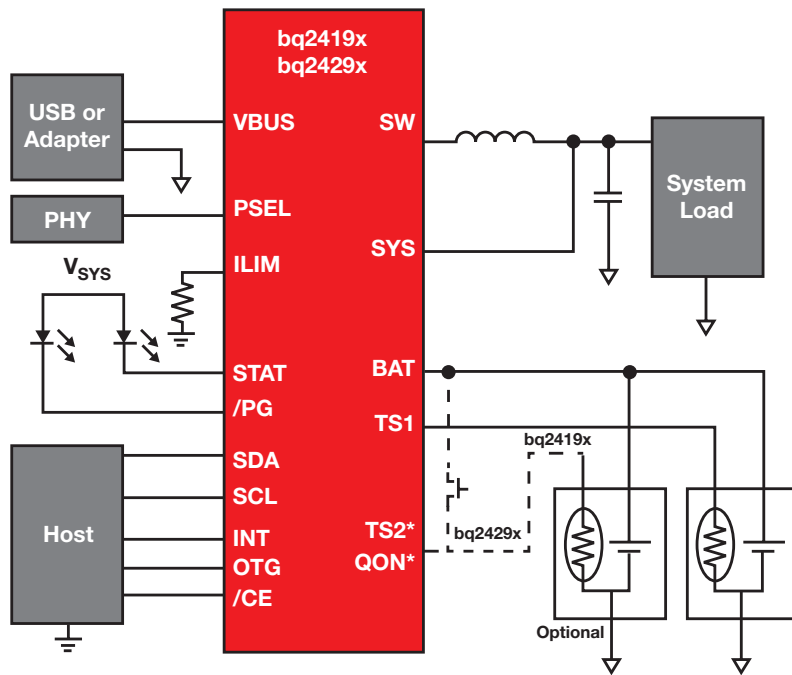

*TS2 for bq2419x, QON for bq2429x

Key Features

- NVDC-1 system with power-path management, system instant-on with no battery or deeply discharged battery
- I²C host control or autonomous charging with default parameters
- High integration including battery FET, AC switching FETS, current sensing and compensation
- Input-voltage range:
 - bq2419x: 3.9 to 17 V
 - bq2429x: 5 V
- USB-compliant 2.5/4.5-A charger with 1.5-MHz switching mode and D+/D- detection or PSEL
- High charging efficiency:
 - bq2419x: 92% at 2.5 A and 90% at 4 A
 - bq2429x: 88% at 2 A
- High USB OTG efficiency: 90% at 1 A
- Programmable thermal-regulation
- 4 x 4-mm QFN package, pin-to-pin compatible

Applications

- Tablets and E-readers
- Fast charging for smartphones
- Applications requiring high instant system power

Get more information: www.ti.com/product/bq24190 or [bq24295](http://www.ti.com/product/bq24295)

Single-Cell Integrated Chargers with I²C

Device	Number of Cells	V _{IN} Abs Max (V)	V _{IN} OVP (V)	Charge Current (A)	Default Charging Current (A)	Charge Voltage (V)	Default Charging Voltage (V)	Topology	Integrated Power FET	Temp Monitor	QFN/MLP	EVM	USB Detection	Price*
Host Control with I²C System Interface or Autonomous Charging and USB OTG														
bq24190	1	20	18	4.5	2	3.5 to 4.4	4.2	Switching	Yes	Yes, Std	24	✓	D+/D-	2.90
bq24192	1	20	18	4.5	2	3.5 to 4.4	4.2	Switching	Yes	Yes, Std	24	✓	PSEL	2.90
bq24192I	1	20	18	4.5	1	3.5 to 4.4	4.1	Switching	Yes	Yes, Std	24	✓	PSEL	2.90
bq24193	1	20	18	4.5	2	3.5 to 4.4	4.2	Switching	Yes	Yes, JEITA	24	✓	PSEL	2.90
bq24196	1	20	18	2.5	2	3.5 to 4.4	4.2	Switching	Yes	Yes, Std	24	✓	PSEL	1.95
bq24296	1	15	6.4	3	2	3.5 to 4.4	4.2	Switching	Yes	Yes, Std	24	✓	PSEL	1.95
bq24297	1	15	6.4	3	2	3.5 to 4.4	4.2	Switching	Yes	Yes, Std	24	✓	D+/D-	1.95

*Suggested resale price in U.S. dollars in quantities of 1,000.

New devices are listed in bold red.

Battery Management Products

Battery Chargers

2.5/4.5/3-A, I²C-Controlled, Single-Cell USB/Adapter Charger with 1.0/2.1/1.5-A Synchronous Boost Operation

bq24195L, bq24195, bq24295

The bq24195L is a fully integrated 2.5-A charger with 1-A synchronous boost operation. The bq24195 is a fully integrated 4.5-A charger with 2.1-A synchronous boost operation. The bq24295 is a fully integrated 3-A 5-V charger with 1.5-A synchronous boost operation. They are the one-chip solutions for 1S battery backup with high synchronous boost efficiency.

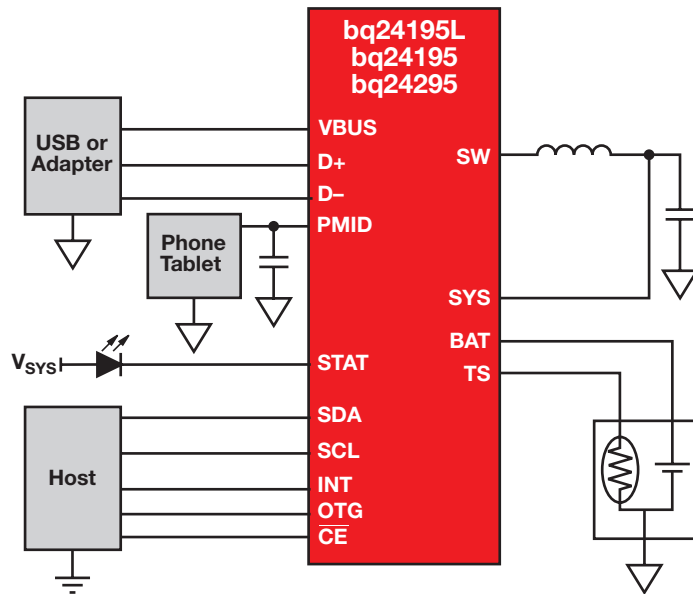

Key Features

- Fully integrated single-chip solution for 1S battery
- USB-compliant 1.5-MHz switching-mode charger with D+/D- detection
- High synchronous boost efficiency:
 - bq2419x: 94% at 1 A and 90% at 2.1 A
 - bq24295: 88% 1.5 A
- High charging efficiency:
 - bq2419x: 92% at 2.5 A and 90% at 4A
 - bq24295: 90% at 2 A
- I²C host control or autonomous charging with default parameters
- Input-voltage range:
 - bq2419x: 3.9 to 17 V
 - bq24295: 5 V
- 4 x 4-mm QFN package, pin-to-pin compatible

Applications

- Power bank, power pack, juice pack for smartphone and tablet backup power

Get more information: www.ti.com/product/bq24195L or [bq24195](http://www.ti.com/product/bq24195)

Single-Cell Integrated Chargers with I²C for Power Bank Applications

Device	Number of Cells	V _{IN} Abs Max (V)	V _{IN} OVP (V)	Charge Current (A)	Default Charging Current (A)	Charge Voltage (V)	Default Charging Voltage (V)	Topology	Integrated Power FET	Temp Monitor	QFN/MLP	EVM	USB Detection	Price*
Host Control with I²C System Interface or Autonomous Charging and Synchronous Boost Operation														
bq24195L	1	20	18	2.5	2	3.5 to 4.4	4.2	Switching	Yes	Yes	24	✓	D+/D-	2.90
bq24195	1	20	18	4.5	2	3.5 to 4.4	4.2	Switching	Yes	Yes	24	✓	D+/D-	3.25
bq24295	1	15	6.4	3	2	3.5 to 4.4	4.2	Switching	Yes	Yes, Std	24	✓	D+/D-	1.95

*Suggested resale price in U.S. dollars in quantities of 1,000.

New devices are listed in bold red.

Battery Management Products

Battery Chargers

2.0-A Switch-Mode Charger with Power-Path Management and Host I²C or Stand Alone Control Option

NEW

bq2425x Family

The bq2425x family of chargers is ideal for space-constrained portable applications. The combination of I²C control and standalone functionality on a single device provides full system-design flexibility across customer platforms. In addition, with a 1- μ A shipmode current, battery life can be extended for accessories applications.

Key Features

- 20-V-input tolerant; operation up to 10.5 V (bq24250/1/3) or 6.5 V (bq24257)
- NVDC architecture
- Input-voltage dynamic power management allows compatibility with multiple external adapter types

- Charge-time optimizer—fastest possible charge rate at any power level
- Compliant with BC1.2 and JEITA standards

bq24250/1/7 Features

- I²C Interface or stand-alone mode in one device

- Automatic USB current setting from D+/D- (bq24251/7) or EN1/EN2 from host (bq24250), compliant with BC1.2
- Programmable battery-charge output between 3.5 and 4.44 V using I²C or 4.2 V fixed

bq24253 Features

- Fixed battery-charge regulation at 4.2 V
- USB charge rate select using D+/D- detection
- Resistor-programmable current limits

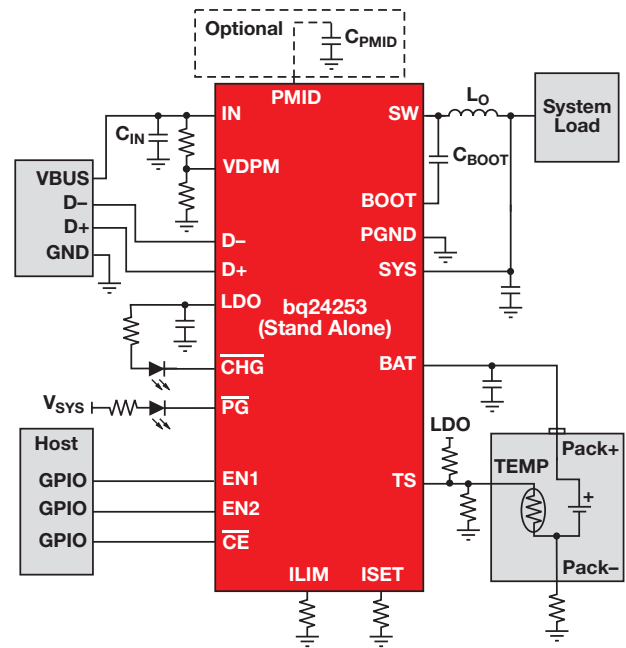
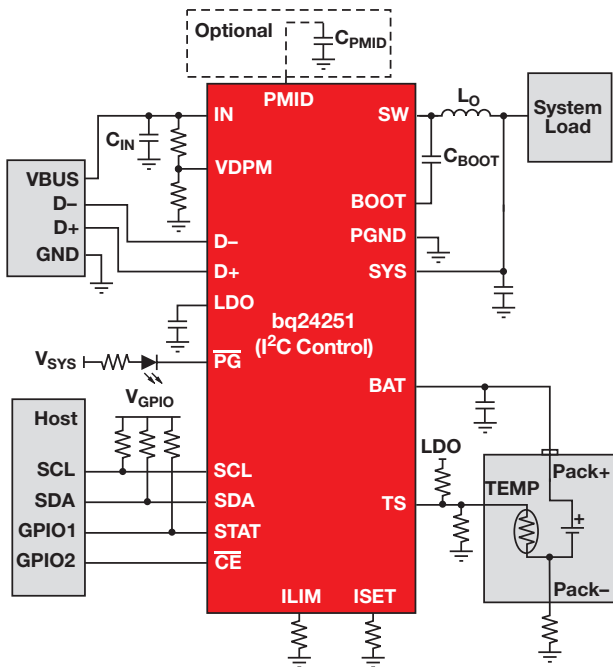

Get more information: www.ti.com/product/bq24251 or [bq24253](http://www.ti.com/product/bq24253)

Selection Guide

Device	Number of Cells	V _{IN} Absolute Max (V)	V _{IN} OVP (V)	Charge Current (A)	Charge Voltage (V)	Control Interface	Topology	Integrated Power FET	Temperature Monitor	Packaging			Comments	Price*
										WCSP	QFN/MLP	EVM		
bq24250/51	1	20	10.5	2.0	3.5 to 4.4	I ² C/Stand Alone	Switching	Yes	Yes	30	24	✓	EN1-2 or D+/D- detection, JEITA, Power Path	1.15
bq24253	1	20	10.5	2.0	4.2	Stand Alone	Switching	Yes	Yes	30	24	✓	D+/D- detection, JEITA, Power Path	1.15
bq24257	1	20	6.5	2.0	3.5 to 4.4	I ² C/Stand Alone	Switching	Yes	Yes	30	24	✓	D+/D- detection, JEITA	1.15

*Suggested resale price in U.S. dollars in quantities of 1,000.

New products are listed in bold red.

Battery Management Products

Battery Chargers

3.0-A-Output, 30-V-Input Switch-Mode Charger with Power-Path Management and USB OTG Support Host, I²C Control or Stand Alone

NEW

bq2426x Family

The bq2426x family of chargers offers higher current levels and wide-input-voltage tolerance. 30-V capability provides a robust system design in a very small footprint.

Key Features

- 30-V-input tolerant; operation up to 6.5 V (bq24262), 10.5 V (bq24260) or 14 V (bq24261/6) allows compatibility with 5-V or 12-V adapter types
- NVDC architecture
- USB OTG support (5-V output at 1 A)
- Charge-time optimizer—fastest possible charge rate at any power level

- Compliant with BC1.2 and JEITA standards

bq24260/1/2 Features

- I²C control
- Automatic USB current setting from D+/D- (bq24260) or PSEL from USB PHY (bq24261/2)

- Programmable battery-charge output between 3.5 and 4.4 V
- Programmable charge-termination current

bq24266 Features

- Stand-alone operation
- Fixed battery-charge regulation at 4.2 V
- Voltage-based, JEITA-compatible NTC monitoring input
- USB input current limit and VinDPM adjustable by host GPIO

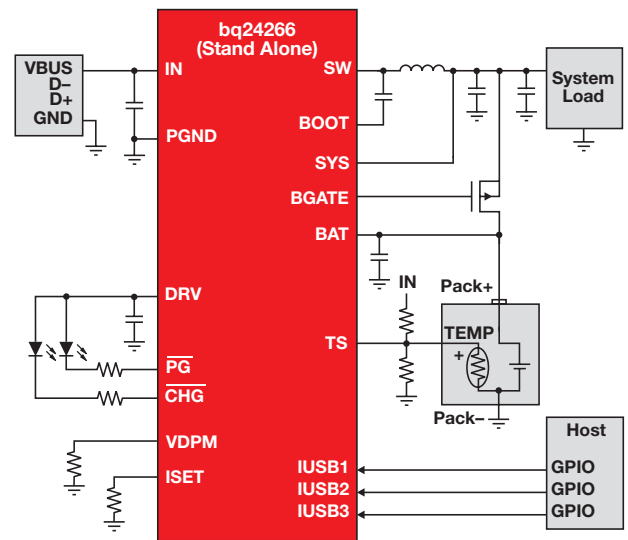
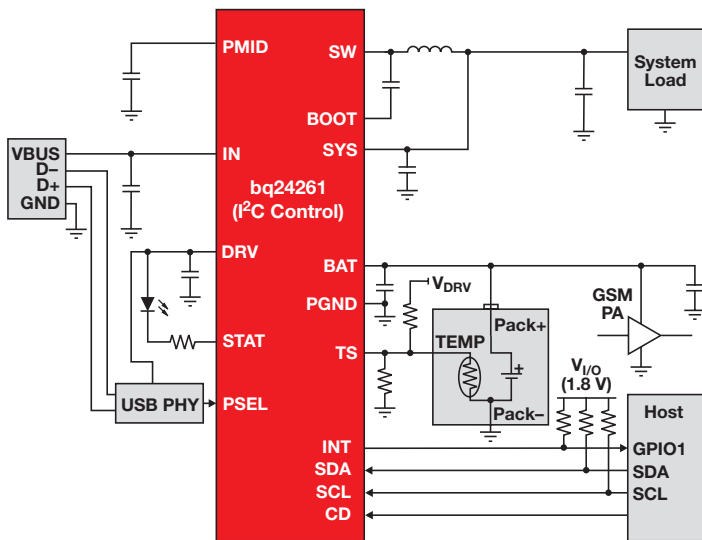

Selection Guide

Device	Number of Cells	V _{IN} Absolute Max (V)	V _{IN} OVP (V)	Charge Current (A)	Charge Voltage (V)	Control Interface	Topology	Integrated Power FET	Temperature Monitor	Packaging			Comments	Price*
										WCSP	QFN/MLP	EVM		
bq24260	1	30	10.5	3.0	3.5 to 4.4	I ² C	Switching	Yes	Yes	36	24	✓	D+/D- detect, JEITA, Power Path, OTG	1.75
bq24261	1	30	14	3.0	3.5 to 4.4	I ² C	Switching	Yes	Yes	36	24	✓	PSEL detect, JEITA, Power Path, OTG	1.75
bq24262	1	30	6.5	3.0	3.5 to 4.4	I ² C	Switching	Yes	Yes	36	24	✓	PSEL detect, JEITA, Power Path, OTG	1.75
bq24266	1	30	14	3.0	4.2	Stand Alone	Switching	Yes	Yes		24	✓	JEITA, Power Path, OTG	1.75

*Suggested resale price in U.S. dollars in quantities of 1,000.

New devices are listed in bold red.

Battery Management Products

Battery Chargers

Switch-Mode Multi-Cell (1 to 3) Li-Ion Battery Chargers with Integrated FETs

bq241xx Family

The bq24170 is a highly integrated stand-alone Li-Ion or Li-Polymer switch-mode battery charger with two integrated N-channel power MOSFETs. It offers a constant-frequency synchronous PWM controller with highly accurate regulation of input current, charge current and voltage. It closely monitors the battery-pack temperature to allow charging only in a preset temperature window. It also provides battery detection, preconditioning, charge termination and charge-status monitoring.

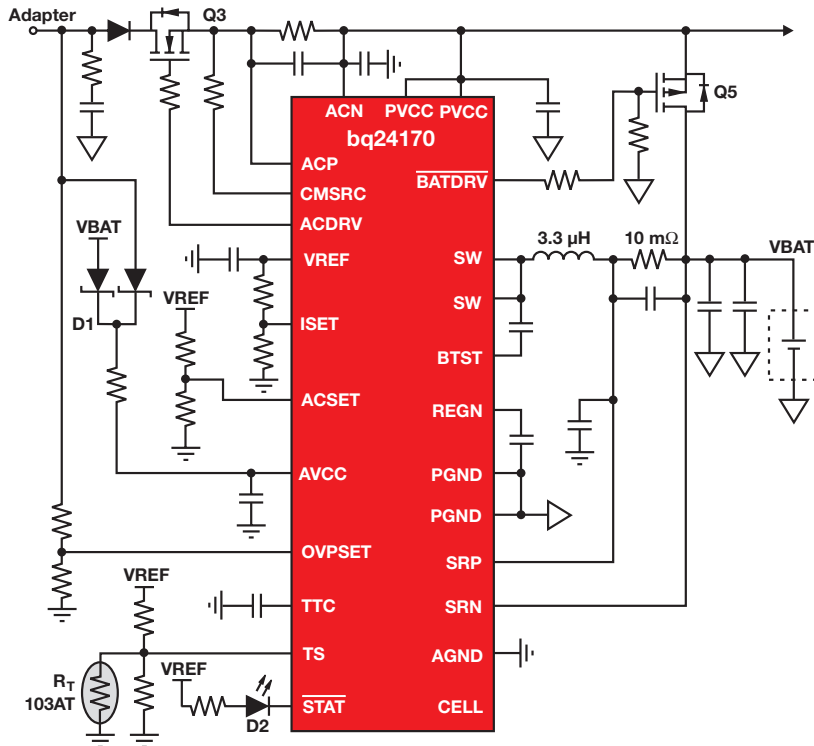

Key Features

- 1.6-MHz synchronous switch-mode charger with 4-A integrated N-channel MOSFETs
- Up to 94% efficiency
- 4.5-V to 17-V input operating range
- Battery charge voltage: 1, 2 or 3 cells with 4.2 V per cell

Applications

- Tablet PCs
- Netbooks and ultra-mobile computers
- Portable data-capture terminals
- Portable printers
- Medical-diagnostics equipment
- Battery-bay chargers
- Battery back-up systems

Get more information: www.ti.com/product/bq24170

Chargers with Internal FETs Selection Guide

Device	Number of Cells	Control Topology	Host or Stand Alone	Integrated Power FET	Charge Current (A)	V _{IN} Max (V)	Primary Charge Termination Method ¹	Safety Timer	Temp Monitor	Packaging: QFN/MLP	EVM	Comments	Price*
Multi-Cell Switch-Mode Stand-Alone Battery Chargers with Internal FETs (Converters) — Lithium-Ion													
bq24170	1 to 3	Switching	Stand Alone	Yes	4.0	20	Min current	Yes	Yes	24	✓	Power Path	1.80
bq24171	1 to 3	Switching	Stand Alone	Yes	4.0	20	Min current	Yes	Yes	24	✓	JEITA Power Path	1.80
bq24172	1 to 3	Switching	Stand Alone	Yes	4.0	20	Min current	Yes	Yes	24	✓	Adjustable charge voltage, Power Path	1.80
bq24133	1 to 3	Switching	Stand Alone	Yes	2.5	20	Min current	Yes	Yes	24	✓	Power Path	1.75
bq24130	1 to 3	Switching	Host	Yes	4.0	20	Min current/Host controlled	—	Yes	20	✓	Charges battery or super capacitor	1.95
bq24100	1	Switching	Stand Alone	Yes	2.0	20	Min current	Yes	Yes	20	✓	On/Off status pin; bq24120 offers enhanced EMI performance	2.00
bq24108	1	Switching	Stand Alone	Yes	2.0	20	Min current	Yes	Yes	20	—	Blinking status pin; bq24120 offers enhanced EMI performance	2.00
bq24103A	1 or 2	Switching	Stand Alone	Yes	2.0	20	Min current/Host controlled	Yes	Yes	20	✓	bq24123 offers enhanced EMI performance	2.00
bq24113A	1 or 2	Switching	Host	Yes	2.0	20	Min current/Host controlled	Yes	Yes	20	✓	bq24123 offers enhanced EMI performance	2.00
bq24105	1 to 3	Switching	Host	Yes	2.0	20	Min current/Host controlled	Yes	Yes	20	✓	bq24125 offers enhanced EMI performance	3.50
bq24115	1 to 3	Switching	Host	Yes	2.0	20	Min current/ Host controlle	Yes	Yes	20	✓	bq24125 offers enhanced EMI performance	3.50

¹Host controlled = system processor must terminate charging.

*Suggested resale price in U.S. dollars in quantities of 1,000.

Battery Management Products

Battery Chargers

Stand-Alone Synchronous Switch-Mode Li-Ion or Li-Polymer Battery Charger

bq246xx

The bq24610 is a highly integrated Li-Ion or Li-Polymer switch-mode battery charger. It offers a constant-frequency synchronous switching PWM controller with highly accurate regulation of charge current and voltage. It also provides charge preconditioning, termination, adapter current regulation and charge-status monitoring.

Key Features

- 600-kHz NMOS/NMOS synchronous buck converter
- Stand-alone charger support for Li-Ion or Li-Polymer battery
- Supports up to six battery cells (bq24610) and has an input operating range of 5- to 28-V V_{CC}
- Up to 10-A charge current and adapter current

Applications

- Netbooks, mobile Internet devices and ultra-mobile PCs
- PDAs
- Handheld terminals
- Industrial and medical equipment

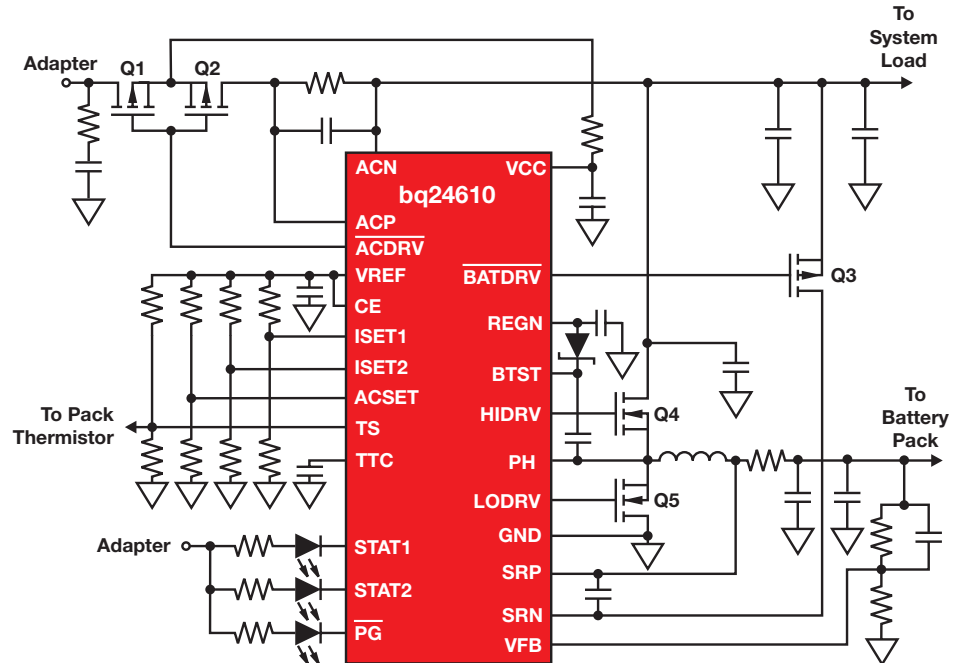

Get more information: www.ti.com/product/bq24610

Multi-Cell Charger Controllers Selection Guide

Device	Number of Cells	Control Topology	Integrated Power FET	V_{IN} Max (V)	Primary Charge Termination Method	Safety Timer	Temp Monitor	Packaging: QFN/MLP	EVM	Comments	Price*
Multi-Cell Switch-Mode Stand-Alone Battery Chargers with External FETs (Controllers) — Lithium-Ion (except where noted)											
bq24600	1 to 6	Switching	No	32	Min current	Yes	Yes	16/24	✓	1200 kHz	2.50
bq24610	1 to 6	Switching	No	32	Min current	Yes	Yes	16/24	✓	600 kHz	2.90
bq24616	1 to 6	Switching	No	32	Min current	Yes	Yes	16/24	✓	JEITA, 600 kHz	2.90
bq24617	1 to 5	Switching	No	26	Min current	Yes	Yes	—	✓	600 kHz	2.90
bq24618	1 to 6	Switching	No	32	Min current	Yes	Yes	16/24	—	Supports 4.7 V_{IN}	2.90
bq24620	1 to 7	Switching	No	32	Min current	Yes	No	16/24	✓	LiFePO ₄	2.90
bq24630	1 to 7	Switching	No	32	Min current	Yes	No	16/24	✓	LiFePO ₄ , system power selector	2.90
bq24640	1 to 9	Switching	No	33	SuperCap-specific	No	Yes	16	✓	Supports SuperCap	3.65
bq24650	1 to 6	Switching	No	33	Min current	Yes	Yes	16	✓	Solar charger for Li-Ion/polymer, LiFePO ₄ , lead-acid chemistries	2.85

*Suggested resale price in U.S. dollars in quantities of 1,000.

Battery Management Products

Battery Chargers

Selection Guide

Device	Number of Cells	V _{IN} Absolute Max (V)	V _{IN} OVP (V)	Charge Current (A)	Charge Voltage (V)	Control Interface	Topology	Integrated Power FET	Temperature Monitor	Packaging			Comments	Price*	
										WCSP	QFN/MLP	EVM			
Multi-Chemistry (Li-Ion or NiCd/NiMH)															
bq24030/31/35	1	18	6.4	2	4.2/4.1/4.2	Stand Alone	Linear	Yes	Yes		20	✓	Regulated 4.4-V output for AC input condition	1.80	
bq24032A/38	1	18	6.4	2	4.2/ (4.24/4.36)	Stand Alone	Linear	Yes	Yes		20	✓	Regulated 4.4-V output for AC input condition	1.80	
bq24040/41	1	30	6.6/7.1	1	4.2	Stand Alone	Linear	Yes	Yes		10	✓		0.45	
bq24045	1	30	6.6/7.1	1	4.35	Stand Alone	Linear	Yes	Yes		10	✓		0.45	
bq24050/52	1	30	6.6	0.8	4.2	Stand Alone	Linear	Yes	Yes		10	✓	JEITA Charging (100K NTC — bq24052)	0.50	
bq24055	1	30	6.6	0.8	4.2	Stand Alone	Linear	Yes	Yes		12	✓	JEITA, PG Pin	0.60	
bq24072/72T	1	28	6.6	1.5	4.3 / 4.2	Stand Alone	Linear	Yes	Yes		16	✓	V _{OUT} tracks V _{BAT} , V _{IN_DPPM}	1.00	
bq24073	1	28	6.6	1.5	4.2	Stand Alone	Linear	Yes	Yes		16	✓	V _{IN_DPPM}	1.00	
bq24074	1	28	10.5	1.5	4.2	Stand Alone	Linear	Yes	Yes		16	✓	V _{IN_DPPM}	1.00	
bq24075T/79T	1	28	6.6	1.5	4.2/4.1	Stand Alone	Linear	Yes	Yes		16	✓	SYSOFF pin disconnects battery, V _{IN_DPPM} , powers system and charges battery	1.00	
bq24090/91	1	12	6.6	1	4.2	Stand Alone	Linear	Yes	Yes		10	✓	10K NTC (100K NTC — bq24091)	0.40	
bq24092/93	1	12	6.6	1	4.2	Stand Alone	Linear	Yes	Yes		10	✓	JEITA, 10K NTC (JEITA, 100K NTC — bq24093)	0.40	
bq24095	1	12	6.6	1	4.35	Stand Alone	Linear	Yes	Yes		10	✓	10K NTC	0.40	
bq24140	1	20	9.8	1.5	Adj	I ² C	Switching	Yes	No		30	✓	Simultaneous charge and USB OTG output	1.60	
bq24153A/58	1	20	6.5	1.25	3.5 to 4.4	I ² C	Switching	Yes	No		20	✓	USB OTG supported with boost, no battery detect on power up (bq24158)	0.95	
bq24156A/59	1	20	9.8	1.5	3.5 to 4.4	I ² C	Switching	Yes	No		20	✓	No battery detect on power up (bq24159)	0.95	
bq24157	1	20	6.5	1.25	3.5 to 4.4	I ² C	Switching	Yes	No		20	✓	USB OTG supported with boost, no battery detect on power up, safety timer disabled	0.90	
bq24160/A	1	20	10.5/6.5(USB)	2.5/1.5	3.5 to 4.4	I ² C	Switching	Yes	Yes		49	24	✓	D+/D- detect, JEITA, 3-V V _{BAT_SHORT}	1.95
bq24161/B	1	20	10.5/6.5(USB)	2.5/1.5	3.5 to 4.4	I ² C	Switching	Yes	Yes		49	24	✓	USB selection pin, std temp	1.95
bq24163	1	20	10.5/6.5(USB)	2.5/1.5	3.5 to 4.4	I ² C	Switching	Yes	Yes		49	24	✓	D+/D- detect, JEITA	1.95
bq24165	1	20	10.5/6.5(USB)	2.5/1.5	4.2	Stand Alone	Switching	Yes	Yes		49	24	✓	I _{USB} 1/2/3 USB select, no temp monitor, JEITA	1.95
bq24166	1	20	10.5/6.5(USB)	2.5/1.5	4.2	Stand Alone	Switching	Yes	Yes		49	24	✓	I _{USB} 1/2/3 USB select, temp monitor, std temp	1.95
bq24167	1	20	10.5/6.5(USB)	2.5/1.5	4.2	Stand Alone	Switching	Yes	Yes		49	24	✓	I _{USB} 1/2/3 USB select, temp monitor, JEITA	1.95
bq24168	1	20	6.5/6.5(USB)	2.5/1.5	3.5 to 4.4	I ² C	Switching	Yes	Yes		49	24	✓	USB select pins, JEITA, no timers	1.95
bq24180	1	20	16.5	1.5	3.5 to 4.4	I ² C	Switching	Yes	Yes		25	24	✓	Accessory power output	1.00
bq24185	1	20	16.5	1.5	3.5 to 4.4	I ² C	Switching	Yes	Yes		25	24	✓	USB OTG supported with boost	1.00
bq24187	1	30	6.5	2.0	3.5 to 4.4	I ² C	Switching	Yes	Yes		36	24	✓	PSEL detect, JEITA, Power Path, OTG	1.75
bq24190	1	20	18	4.5	3.5 to 4.4	I ² C/Stand Alone	Switching	Yes	Yes		24	24	✓	D+/D-, 1.3-A OTG, standard temp., 12-mΩ battery FET	2.90
bq24192	1	20	18	4.5	3.5 to 4.4	I ² C/Stand Alone	Switching	Yes	Yes		24	24	✓	PSEL, 1.3-A OTG, standard temp., 12-mΩ battery FET	2.90
bq24192I	1	20	18	4.5	3.5 to 4.4	I ² C/Stand Alone	Switching	Yes	Yes		24	24	✓	PSEL, 1.3-A OTG, standard temp., 1-A default charging	2.90
bq24193	1	20	18	4.5	3.5 to 4.4	I ² C/Stand Alone	Switching	Yes	Yes		24	24	✓	PSEL, 1.3-A OTG, JEITA, 12-mΩ battery FET	2.90
bq24196	1	20	18	2.5	3.5 to 4.4	I ² C/Stand Alone	Switching	Yes	Yes		24	24	✓	PSEL, 1.3-A OTG, standard temp., 12-mΩ battery FET	1.95
bq24195L	1	20	18	2.5	3.5 to 4.4	I ² C/Stand Alone	Switching	Yes	Yes		24	24	✓	D+/D-, 1.0-A synchronous boost for power bank	2.90
bq24195	1	20	18	4.5	3.5 to 4.4	I ² C/Stand Alone	Switching	Yes	Yes		24	24	✓	D+/D-, 2.1-A synchronous boost for power bank	3.25
bq24232	1	28	10.5	0.5	4.2	Stand Alone	Linear	Yes	Yes		16	✓	SYSOFF pin disconnects battery, V _{IN_DPPM} , powers system and charges battery	1.00	
bq24232H	1	28	10.5	0.5	4.35	Stand Alone	Footnote 1	Yes	Yes		16	✓	Higher voltage battery pack flexibility (4.35 V), USB friendly, powers system and charges battery	1.15	
bq24250/51	1	20	10.5	2.0	3.5 to 4.4	I ² C/Stand Alone	Switching	Yes	Yes		30	24	✓	EN1-2 or D+/D- detection, JEITA, Power Path	1.15
bq24253	1	20	10.5	2.0	4.2	Stand Alone	Switching	Yes	Yes		30	24	✓	D+/D- detection, JEITA, Power Path	1.15
bq24257	1	20	6.5	2.0	3.5 to 4.4	I ² C/Stand Alone	Switching	Yes	Yes		30	24	✓	D+/D- detection, JEITA	1.15
bq24260	1	30	10.5	3.0	3.5 to 4.4	I ² C	Switching	Yes	Yes		36	24	✓	D+/D- detect, JEITA, Power Path, OTG	1.75
bq24261	1	30	14	3.0	3.5 to 4.4	I ² C	Switching	Yes	Yes		36	24	✓	PSEL detect, JEITA, Power Path, OTG	1.75
bq24262	1	30	6.5	3.0	3.5 to 4.4	I ² C	Switching	Yes	Yes		36	24	✓	PSEL detect, JEITA, Power Path, OTG	1.75
bq24266	1	30	14	3.0	4.2	Stand Alone	Switching	Yes	Yes		24	24	✓	JEITA, Power Path, OTG	1.75
bq24270/71	1	20	6.5	1.5	3.5 to 4.4	I ² C	Switching	Yes	Yes		49	24	✓	D+/D- detect or PSEL, JEITA, Power Path	1.25
bq24272	1	20	10.5	2.5	3.5 to 4.4	I ² C	Switching	Yes	Yes		49	24	✓	Power Path	1.25
bq24273	1	20	10.5	2.5	3.5 to 4.4	I ² C	Switching	Yes	Yes		49	24	✓	non-Power Path	1.25
bq24278	1	20	10.5	2.5	4.2	Stand Alone	Switching	Yes	Yes		49	24	✓	Input current limit programming input	1.25
bq25040	1	30	6.9	1.1	4.2	Stand Alone	Linear	Yes	Yes		10	✓	USB compliant w/50-mA integrated LDO	0.55	
bq25050	1	30	6.5	1	4.2	Single Wire	Linear	Yes	Yes		10	✓	Single-wire interface	0.60	
bq25060	1	30	10.5	1	4.2	Stand Alone	Linear	Yes	Yes		10	✓	USB compliant w/50-mA integrated LDO	0.65	

¹Linear/Switch-Mode/CC/CV

*Suggested resale price in U.S. dollars in quantities of 1,000.

New devices are listed in bold red.

Battery Management Products

Battery Chargers

Selection Guide (Continued)

Device	Number of Cells	V _{IN} Absolute Max (V)	V _{IN} OVP (V)	Charge Current (A)	Charge Voltage (V)	Control Interface	Topology	Integrated Power FET	Temperature Monitor	Packaging			EVM	Comments	Price*
										WCSOP	QFN/MLP				
Multi-Chemistry (Li-Ion or NiCd/NiMH) (Continued)															
bq25100	1	30	6.5	0.25	4.2	Stand Alone	Linear	Yes	Yes	6		✓	Small solution with 1-mA termination support and extremely low battery leakage	0.75	
bq25100A	1	30	6.5	0.25	4.3	Stand Alone	Linear	Yes	Yes	6		—	Small solution with 1-mA termination support and extremely low battery leakage	0.75	
bq25100H	1	30	6.5	0.25	4.35	Stand Alone	Linear	Yes	Yes	6		—	Small solution with 1-mA termination support and extremely low battery leakage	0.75	
bq25101	1	30	6.5	0.25	4.2	Stand Alone	Linear	Yes	Yes	6		—	Small solution with 1-mA termination support and extremely low battery leakage. Charge pin indication	0.75	
bq24130	1 to 3	20	Adj	4	Adj	I ² C	Switching	Yes	Yes	20		✓	Host control, supports Li-Ion and Super Cap	1.95	
bq24133	1 to 3	20	Adj	2.5	4.2/Cell	Stand Alone	Switching	Yes	Yes	24		✓	Power Path	1.75	
bq24170	1 to 3	20	Adj	4	4.2/Cell	Stand Alone	Switching	Yes	Yes	24		✓	Power Path	1.80	
bq24171	1 to 3	20	Adj	4	Adj	Stand Alone	Switching	Yes	Yes	24		✓	JEITA, Power Path	1.80	
bq24172	1 to 3	20	Adj	4	Adj	Stand Alone	Switching	Yes	Yes	24		✓	Adjustable charge voltage, Power Path	1.80	
bq24707A	1 to 4	30	Adj	8	Adj	SMBus	Switching	No	No	20		✓	Programmable switching frequency	2.90	
bq24735	1 to 4	30	Adj	8	Adj	SMBus	Switching	No	No	20		✓	Intel CPU Turbo Mode support	3.00	
bq24617	1 to 5	33	32	10 (Ext)	Adj	Stand Alone	Switching	No	Yes	24		✓	600 kHz	2.75	
bq24600	1 to 6	33	32	10 (Ext)	Adj	Stand Alone	Switching	No	Yes	16		✓	1200 kHz	2.00	
bq24610	1 to 6	33	32	10 (Ext)	Adj	Stand Alone	Switching	No	Yes	24		✓	600 kHz	2.75	
bq24616	1 to 6	33	32	10 (Ext)	Adj	Stand Alone	Switching	No	Yes	24		✓	JEITA	2.75	
bq24618	1 to 6	33	32	10 (Ext)	Adj	Stand Alone	Switching	No	Yes	24		✓	USB V _{IN} and adapter	2.75	
bq24715	2 to 3	30	26	8	Adj	SMBus	Switching	No	No	20		✓	NVDC charger	2.25	
bq24725A	2 to 4	30	Adj	8	Adj	SMBus	Switching	No	No	20		✓	Programmable switching frequency, enhanced safety, battery learn	2.00	

Device	Number of Cells	V _{IN} Absolute Max (V)	V _{IN} OVP (V)	Charge Current (A)	Charge Voltage (V)	Control Interface	Topology	Integrated Power FET	Temperature Monitor	Packaging			EVM	Comments	Price*	
										QFN/MLP	TSSOP	SOIC				DIP
Solar/Energy Harvesting (Li-Ion)																
bq24210	1	20	7.7	0.800	4.2	Stand Alone	Linear	Yes	Yes	10			✓	Solar panel V _{IN}	1.10	
bq25504	1	5.5	Adj	0.1	2.5 to 5.25	Stand Alone	Boost	Yes	Yes	16			✓	Energy harvester, ultra-low power and quiescent current, high efficiency, dynamic MPPT	2.10	
bq25505	1	5.5	Adj	0.1	2.5 to 5.25	Stand Alone	Boost	Yes	Yes	16			✓	Energy harvester, 330-nA ultra-low power and quiescent current, high efficiency, dynamic MPPT, autonomous power-path multiplexing	2.40	
bq25570	1	5.5	Adj	0.1	2.5 to 5.25	Stand Alone	Boost-Buck	Yes	Yes	16			✓	Energy harvester, <488-nA ultra-low power and quiescent current, high efficiency, dynamic MPPT	2.90	
bq24650	1 to 6	33	32	10 (Ext)	Adj	Stand Alone	Switching	No	Yes	16			✓	Max power point tracking (MPPT)	2.85	
LiFePO₄																
bq25070	1	30	10.5	1	3.5	Stand Alone	Linear	Yes	Yes	10			✓	LiFePO ₄ , 50-mA LDO	0.75	
bq25071	1	30	10.5	1	3.5	Stand Alone	Linear	Yes	Yes	10			✓	Standard one charger solution for LiFePO ₄ and 50-mA LDO	0.75	
bq24620	1 to 7	33	32	10 (Ext)	Adj	Stand Alone	Switching	No	Yes	16			✓	LiFePO ₄ , 300 kHz	2.90	
bq24630	1 to 7	33	32	10 (Ext)	Adj	Stand Alone	Switching	No	Yes	24			✓	LiFePO ₄ , 300 kHz, power selector	2.90	
Super Cap																
bq24640	1 to 9	33	32	10 (Ext)	Adj	Stand Alone	Switching	No	Yes	16			✓	SuperCap	2.90	
NiCd/NiMH Chemistry																
bq2002/C/E/F	Multiple	7	—	>2	6	Stand Alone	Current-limited	No	Yes			8	8	—	Trickle charge	0.85
bq2004/E/H	Multiple	7	—	>2	5.5	Stand Alone	Switching	No	Yes			16	16	—	Selectable timers and pulse-trickle rates	2.15
bq2005	Multiple	7	—	>2	5.5	Stand Alone	Switching	No	Yes			20	20	—	Sequential fast charge of two battery packs	2.15
bq24400/1	Multiple	7	—	>2	5.5	Stand Alone	Switching	No	Yes	8	8			—		1.55

*Suggested resale price in U.S. dollars in quantities of 1,000.

New devices are listed in bold red.

Battery Management Products

Battery Chargers

Selection Guide (Continued)

Device	Number of Cells	V _{IN} Absolute Max (V)	V _{IN} OVP (V)	Charge Current (A)	Charge Voltage (V)	Control Interface	Topology	Integrated Power FET	Temperature Monitor	Packaging				EVM	Comments	Price*	
										QFN/MLP	TSSOP	SOIC	DIP				
Lead-Acid Chemistry																	
bq24450	Multiple	40	—	>2	—	Stand Alone	Linear	No	No			16	16	—	Temp-compensated internal reference	2.75	
bq2031	Multiple	7	—	>2	—	Stand Alone	Switching	No	Yes			16	16	✓	Three user-selectable charge algorithms to accommodate cyclic and standby applications	2.80	
Multi-Chemistry (Li-Ion and NiCd/NiMH)																	
bq2000/T	Multiple	7	—	—	—	Stand Alone	Switching	Yes	Yes			8	8	8	✓	Charges NiCd, NiMH, and Li-Ion	1.50
bq24650	1 to 6	33	32	10 (Ext)	Adj	Stand Alone	Switching	No	Yes	16					✓	Max power point tracking	2.85
bq24765	2 to 4	30	—	—	—	Stand Alone	Switching	Yes	No	34					✓	SMBus charger with integrated power FETs	3.95

*Suggested resale price in U.S. dollars in quantities of 1,000.

New devices are listed in **bold red**.

Device	Standard	Output Current (A)	Output Voltage (V)	Function	V _{IN} Absolute Max (V)	Control Interface	Integrated FET	Temperature Monitor	Package	Chip Scale (mm)	EVM	Comments	Price*
Wireless Power Receivers													
bq51003	WPC v1.1	0.5	5	Power Supply	20	Stand Alone	Yes	Yes	CSP	3x2x0.5	✓	2.5-W WPC v1.1 receiver solution for wearable applications	1.30
bq51013B	WPC v1.1	1	5	Power Supply	20	Stand Alone	Yes	Yes	QFN	3x2x0.5	✓	5-W WPC v1.1 receiver solution	1.50
bq51050B/51B	WPC v1.1	1	4.2/4.35	Battery Charger	20	Stand Alone	Yes	Yes	QFN	3x2x0.5	✓	5-W direct battery charger, WPC v1.1 receiver solution	1.90
bq51010B	WPC v1.1	1	7	Power Supply	20	Stand Alone	Yes	Yes	QFN	3x2x0.5	✓	5-W WPC v1.1 receiver solution with 7-V outputs for reduced power loss	1.70
bq51020	WPC v1.1	1.5	Adj (4-8)	Power Supply	20	Stand Alone	Yes	Yes	CSP	3.6x2.9x0.5	✓	High-efficiency, 5-W WPC v1.1 receiver solution with adjustable output voltage	2.50
bq51021	WPC v1.1	1.5	Adj (4-8)	Power Supply	20	I ² C	Yes	Yes	CSP	3.6x2.9x0.5	✓	High-efficiency, 5-W WPC v1.1 receiver solution with adjustable output voltage and I ² C control	2.60
bq51221	WPC v1.1/ PMA	1.5	Adj (4-8)	Power Supply	20	I ² C	Yes	Yes	CSP	3.6x2.9x0.5	✓	Dual-mode, high-efficiency, 5-W WPC v1.1 and PMA receiver solution	3.00
bq51025	WPC v1.1	2	Adj (4.5-10)	Power Supply	20	I ² C	Yes	Yes	—	3.6x2.9x0.5	✓	Low WPC v.1.1 receiver to be used with the bq500215	4.00

*Suggested resale price in U.S. dollars in quantities of 1,000.

New devices are listed in **bold red**.

Device	Standard	Coil Type	Number of Coils Supported	V _{IN} (V)	Power (W)	Dynamic Power Limit	Automotive Qualified	Comments	Price*
Wireless Power Transmitters									
bq500210	WPC v1.0	A1/A10	1	19	5	No	No	WPC v1.0 transmitter solution for 19-V systems	1.90
bq500212A	WPC v1.1	A5/A11	1	5	5	Yes	No	Latest WPC v1.1, 5-V transmitter with reduced BOM and improved, simplified FOD	2.00
bq500412	WPC v1.1	A6	1,2,3	12	5	Yes	No	Latest WPC v1.1, A6 transmitter with reduced BOM and improved, simplified FOD	2.10
bq500414Q	WPC v1.1	A6	1,2,3	12	5	No	Yes	AEC-Q100-qualified A6 transmitter for automotive applications	3.40
bq500215	WPC v1.1	A29	1	12	5	No	No	WPC v1.1 receiver to be used with the bq51025	4.00

*Suggested resale price in U.S. dollars in quantities of 1,000.

New devices are listed in **bold red**.
Preview devices are listed in **bold teal**.

For a complete list of resources, visit: www.ti.com/chargers or www.ti.com/wirelesspower

Battery Management Products

Battery Charger Protection

Li+ Charger Front-End Protection IC

bq24314

Charger front-end protection devices provide protection from input overvoltage, input overcurrent and battery overvoltage conditions. The tri-level protection offers maximum safety when charging a handheld device. With integrated FET, the protection device comes in 2x2-mm and 3x4-mm SON packages.

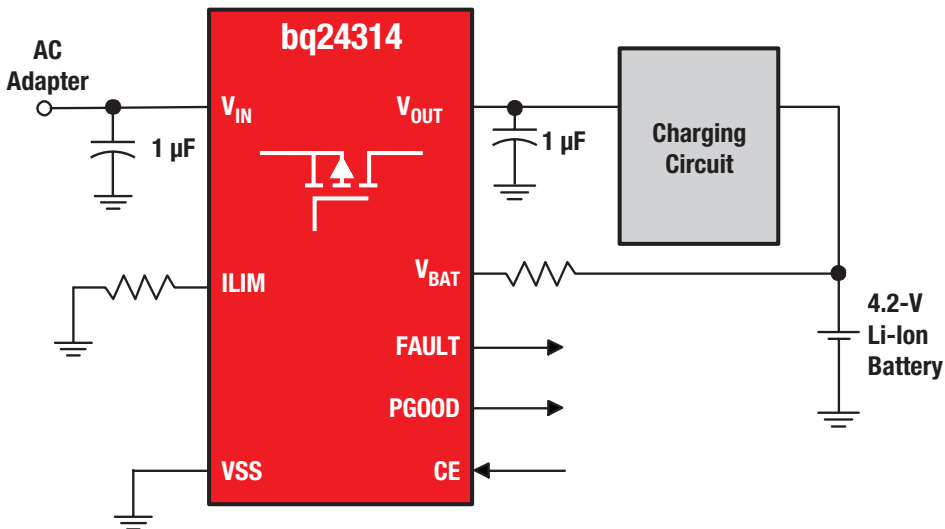

Key Features

- 30-V maximum input
- Up to 1.5-A input current
- Thermal shutdown
- Enable input
- Provides protection for three variables:
 - Input overvoltage (rapid response <1 µs)
 - User-programmable overcurrent with current limiting
 - Battery overvoltage

Applications

- Mobile phones and smartphones
- Portable navigation devices
- MP3 players
- Low-power handheld devices
- Bluetooth® headsets

Get more information: www.ti.com/product/bq24314

Selection Guide

Device	V _{IN} Max (V)	OVP (V)	OCP	Battery OVP (V)	LDO Output (V)	Max Operating Current (µA)	Package(s)	EVM	Comments	Price*
bq24300/4/5	30	10.5	Fixed 300 mA	4.35	5.5/4.5/5.0	400/500/500	8-QFN/SON	✓	Reverse polarity protection	0.30
bq24308	30	6.3	Fixed 700 mA or Prog. <1.5 A	4.35	5	500	8-QFN/SON	✓	Reverse polarity protection	0.30
bq24312	30	5.85	Prog. <1.5 A	4.35	—	500	8/12-QFN/SON	—	Fault indication	0.35
bq24313	11	10.5	Prog. <1.5 A	4.35	—	500	8/12-QFN/SON	—	Fault indication	0.35
bq24314/A	30	5.85	Prog. <1.5 A	4.35	—	600	8/12-QFN/SON	✓	Fault indication	0.35
bq24314C	30	5.85	Prog. <1.5 A	4.45	—	600	8/12-QFN/SON	✓	Fault indication	0.35
bq24315	30	5.85	Prog. <1.5 A	4.35	5.5	600	8-QFN/SON	✓	Fault indication	0.35
bq24316	30	6.8	Prog. <1.5 A	4.35	—	600	8/12-QFN/SON	✓	Fault indication	0.35
bq24380	30	6.3	No OCP	4.35	5.5	250	8-QFN/SON	✓	Fault indication	0.25
bq24381	30	7.1	No OCP	4.35	5	300	8-QFN/SON	✓	Fault indication	0.25
bq24382	30	10.5	No OCP	4.35	5	300	8-QFN/SON	—	Fault indication	0.25
bq24350	30	6.17	Fixed 1.2 A	4.35	5.5	500	8-QFN/SON	✓	Integrated charge FET	0.40
bq24351	30	10.5	Fixed 1.2 A	4.35	6.38	500	8-QFN/SON	✓	Integrated charge FET	0.40
bq24352	30	7.1	Fixed 1.2 A	4.35	5.5	500	8-QFN/SON	✓	Integrated charge FET	0.40

*Suggested resale price in U.S. dollars in quantities of 1,000.

Battery Management Products

Battery Fuel Gauges—Single-Cell Solutions

Design Factors

Battery Chemistry — Each battery chemistry has different operating characteristics, such as discharge profiles and the self-discharge rate. The battery chemistry is programmed in the dataflash of the TI fuel gauge to account for these differences. In addition, the conditions of the end-equipment system can be programmed in the gauge. Designers can choose to implement the

gauge in the host system or inside the pack. The programmed information is processed in TI's Impedance Track™ gauging technology for prediction of remaining battery capacity with >99% accuracy.

Features

TI gas gauges and battery monitors accurately track battery activity to compute the remaining battery capacity and system run-time.

Available features:

- Patented Impedance Track battery fuel-gauging technology for >99% accuracy
- System- and pack-side implementation
- Turnkey solution with complete CPU and battery fuel-gauge firmware
- Interrupt-driven gas gauge signaling the host with the battery's specific state-of-charge status
- Gas gauge with integrated LDO in small packages

System-Side Impedance Track™ Fuel Gauge with Integrated LDO

bq27520

The bq27520 is a high-performance, system-side fuel gauge with excellent accuracy, low power consumption and extremely small package size. By integrating the fuel-gauge function into the system board, portable-equipment designers can use either embedded or removable standard battery packs while adding the capability to accurately display remaining pack capacity and estimated run time. The bq27520 features an integrated voltage regulator that reduces the total component count for the system.

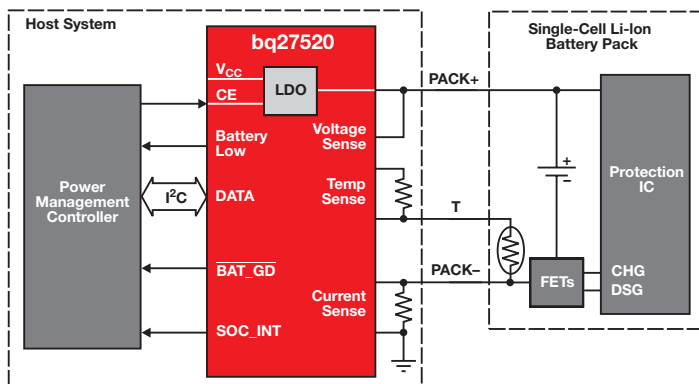

Get more information: www.ti.com/product/bq27520

Key Features

- Interrupt-generation capability reduces software burden on the system processor
- Patented Impedance Track™ algorithm for fuel gauging provides information such as remaining battery capacity, state of charge, minimum run time to empty, battery voltage, temperature and state of health.
- Requires only PACK+ (P+), PACK- (P-) and thermistor (T) connections to a removable battery pack or embedded battery circuit

Selection Guide

Device	Min Max Series Cell	SHA-1 Authentication	System or Pack	Communication Protocol	Other Features	Package	Price*
Lithium-Ion, Lithium-Polymer Chemistry							
bq27411-G1	1	—	Pack	I ² C	Pack-side Impedance Track™ fuel gauge/battery gas gauge	12-pin SON	1.15
bq27541-G1	1	Yes	Pack	I ² C/HDQ	Pack-side fuel gauge with Impedance Track technology	12-pin SON	1.45
bq27742-G1	1	Yes	Pack	I ² C/HDQ	Single-cell Li-Ion battery fuel gauge with integrated protection	15-pin CSP	1.45
bq27621-G1	1	—	System	I ² C	System-side fuel gauge with dynamic voltage correlation battery gas gauge	9-pin CSP	1.10
bq27441-G1	1	—	System	I ² C	System-side Impedance Track battery fuel gauge	12-pin SON	1.15
bq27421	1	—	System	I ² C	System-side fuel gauge with Impedance Track technology with integrated sense resistor	9-pin CSP	1.40
bq27425	1	—	System	I ² C	System-side fuel gauge with Impedance Track Lite technology with integrated sense resistor	15-ball CSP	1.40
bq27510-G3	1	—	System	I ² C	System-side fuel gauge with Impedance Track technology with integrated LDO	12-pin SON	1.45
bq27520-G4	1	—	System	I ² C	System-side fuel gauge with Impedance Track technology with integrated LDO	15-ball CSP	1.50
bq2753x	1	—	System	I ² C	Impedance Track technology fuel gauge with charger control	15-pin CSP	1.80

*Suggested resale price in U.S. dollars in quantities of 1,000.

New devices are listed in bold red.

Battery Management Products

Battery Fuel Gauges—Multi-Cell Solutions

Design Factors

Battery Chemistry — Each battery chemistry has different operating characteristics, such as discharge profiles and self-discharge rate. TI gas gauge devices are developed by chemistry to account for these differences to accurately display remaining energy in the battery.

Features

TI gas gauges and battery monitors accurately track battery activity to compute the remaining battery capacity and system run-time. They feature:

- Simple communication protocols
- High-resolution analog-to-digital converters for accurate charge/discharge measurement

- Integrated CPU on gas gauges to compute remaining battery capacity and run-time
- Advanced charge management satisfies JEITA specification of variable charging current and voltage with battery conditions

99% Accurate Gas Gauge Maximizes Run-Time

bq40z50

The bq40z50 device, incorporating patented Impedance Track™ technology, is a fully-integrated, single-chip, pack-based solution that provides a rich array of features for gas gauging, protection, and authentication for 1-series, 2-series, 3-series, and 4-series cell Li-Ion and Li-Polymer battery packs.

Using its integrated high-performance analog peripherals, the bq40z50 device measures and maintains an accurate record of available capacity, voltage, current, temperature, and other critical parameters in Li-Ion or Li-Polymer batteries, and reports this information to the system host controller over an SMBus v1.1 compatible interface.

Applications

- Notebook/ netbook PCs
- Medical and test equipment
- Portable instrumentation

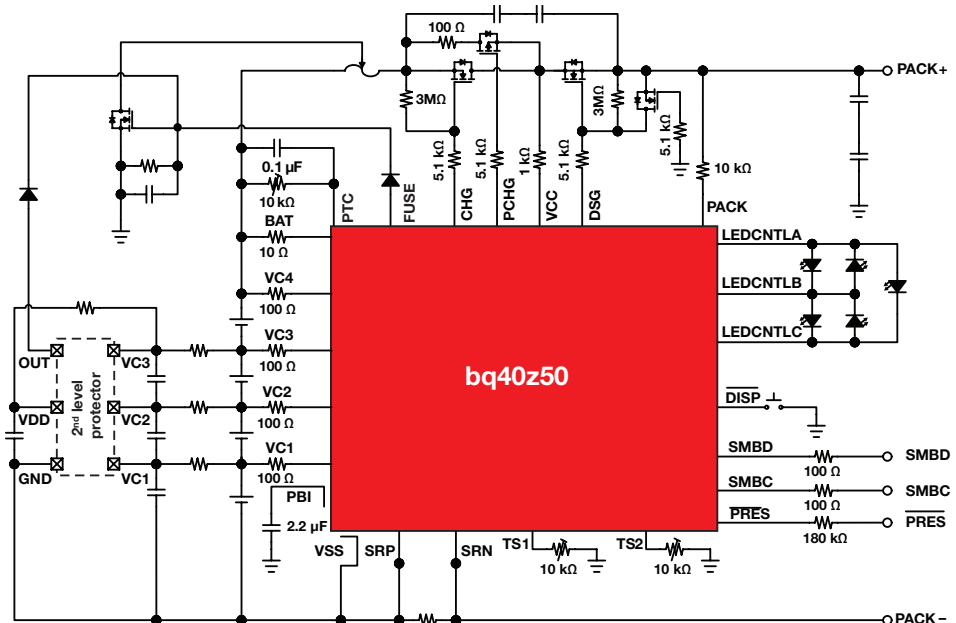

Get more information: www.ti.com/product/bq40z50

Multi-Cell Fuel Gauges Selection Guide

Device	Approx. Battery Capacity (mAh)	Min Max Series Cell	Number of LEDs	Communication Protocol	Other Features	Package	Price*
Lithium-Ion, Lithium-Polymer, LiFePO₄ Chemistry							
bq3060	500 to 32000	2 to 4	—	SMBus	CEDV+ gas gauge with integrated protector	24-pin TSSOP	3.55
bq40z50	500 to 32000	1 to 4	3, 4, or 5	SMBus	Fully integrated, single-chip, pack-based solution with protection and authentication with SHA-1 encryption and features high-side N-channel FET drive	32-pin QFN	3.45
bq20z655-R1	800 to 32000	2 to 4	3, 4, 5 or LCD	SMBus	Impedance Track™ fuel gauge with LED or LCD and integrated protector	44-pin TSSOP	5.20
bq34z950	800 to 32000	2 to 4	3, 4 or 5	SMBus or HDQ	Gas gauge and protection with Impedance Track technology	44-pin TSSOP	2.30
bq78350	—	3 to 15	1 to 5	SMBus	CEDV Li-Ion and LiFePO ₄ battery management controller that is companion to bq769x0 family	30-pin TSSOP	2.20
Lead Acid Chemistry							
bq34z110	Up to 650 Ah	1 to 16	4	I ² C or HDQ	Wide-range fuel gauge with Impedance Track technology	14-pin TSSOP	3.90
Super Cap							
bq33100	—	2 to 5	—	SMBus	Fully integrated 2, 3, 4 and 5 series super capacitor manager	24-pin TSSOP	4.20

*Suggested resale price in U.S. dollars in quantities of 1,000.

New devices are listed in bold red.

Battery Management Products

Battery Fuel Gauges—Multi-Cell Solutions

Multi-Cell Fuel Gauges Selection Guide

Device	Approx. Battery Capacity (mAh)	Min Max Series Cell	Number of LEDs	Communication Protocol	Other Features	Package	Price*
Battery Monitors							
bq76920	—	3 to 5	—	I ² C	Battery monitor with digital I ² C interface, integrated ADCs and hardware protection	20-pin TSSOP	1.50
bq76930	—	6 to 10	—	I ² C	Battery monitor with digital I ² C interface, integrated ADCs and hardware protection	30-pin TSSOP	2.75
bq76940	—	9 to 15	—	I ² C	Battery monitor with digital I ² C interface, integrated ADCs and hardware protection	44-pin TSSOP	3.95
bq76925	—	3 to 6	—	I ² C	Battery monitor with analog voltage output and hardware short circuit detection	20-pin TSSOP or 24-pin QFN	0.99
bq76PL536A	—	3 to 192	—	SPI	3-6S EV and UPS stackable analog front-end with integrated precision ADC and SPI interface, AEC-100 qualified	64-pin HTQFP	6.30
bq77PL900	—	5 to 10	—	I ² C	Dual-mode analog front-end and standalone voltage, current and temperature pack protector	48-pin SSOP	2.95

*Suggested resale price in U.S. dollars in quantities of 1,000.

New devices are listed in bold red.

Li-Ion and Li-Phosphate Battery Monitors

bq769x0

The bq769x0 family of robust analog front-end (AFE) devices serves as part of a complete pack monitoring and protection solution for next-generation, high-power systems. Typical applications are light electric vehicles, power tools, and uninterruptible power supplies. The bq769x0 is designed with low power in mind. The bq76920 device supports up to 5-series cells or typical 18-V packs; the bq76930 handles up to 10-series cells or typical 36-V packs; and the bq76940 works for up to 15-series cells or typical 48-V packs. A variety of battery chemistries may be managed with these AFEs, including Lithium Ion, Lithium iron phosphate, and more.

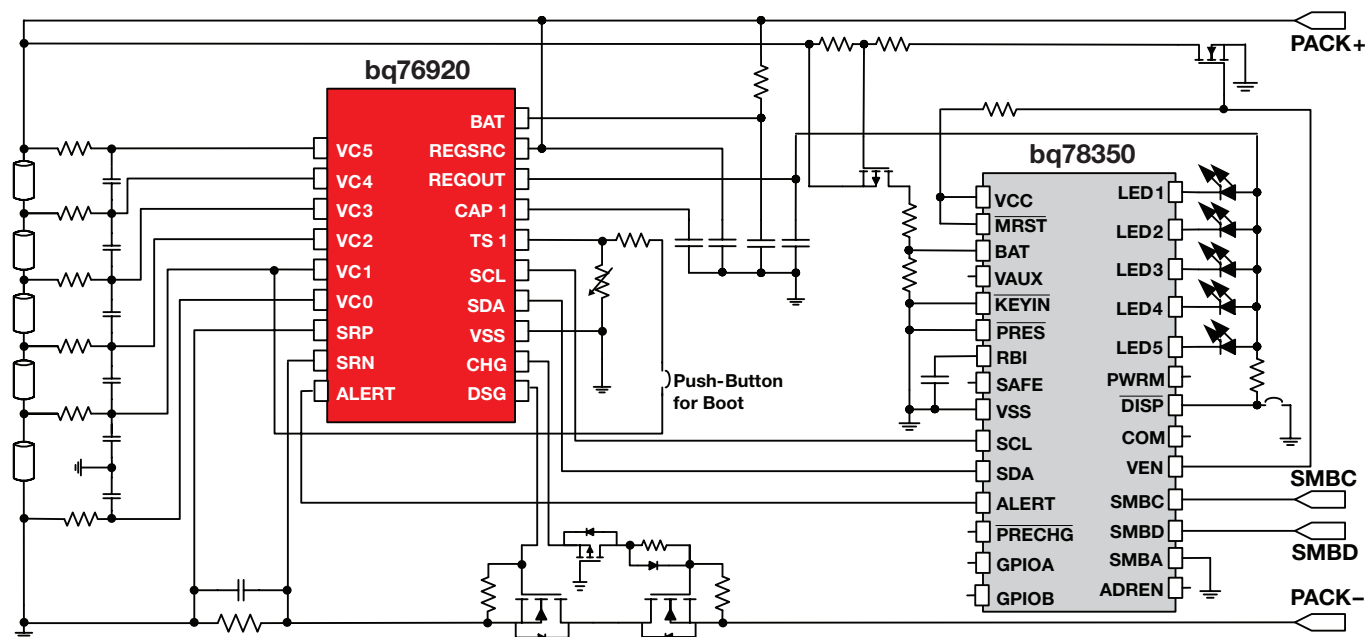

Find out more information about the bq769x0 family at www.ti.com/bmsindustrial

Battery Management Products

Battery and Peripheral Authentication

Design Factors

Original equipment manufacturers specify products to achieve required performance and safety goals. Authentication ensures that connected devices fulfill the established requirements and are safe for the consumer.

Features

TI authentication devices use three levels of security:

- **Identification Number** — The host controller can request an identification number that is answered with a fixed response
- **CRC Algorithm** — The host processor sends a random challenge and reads the response that is an encoding of the challenge and a shared secret key through a CRC with a shared secret polynomial
- **SHA-1 Encryption** — The host processor sends a random challenge and reads the response that is an encoding of the challenge and a shared secret key through the SHA-1 cryptographic primitive

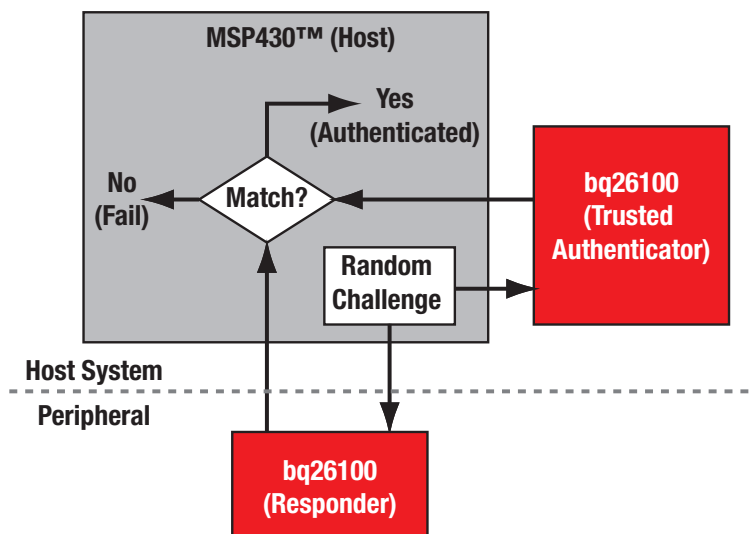

Single-cell battery pack with gas gauge and authentication.

Selection Guide

Device	Interface	Pins	Security	Temp (°C)	Price*
bq2022A	SDQ	3	ID number	-40 to 85	0.90
bq2024	SDQ	3	ID number	-40 to 85	0.95
bq2026	SDQ	3	CRC	-20 to 70	0.90
bq26100	SDQ	5	SHA-1 encryption	-20 to 70	0.99
bq27541	I ² C/HDQ	12	SHA-1 encryption	-40 to 85	1.45
bq27742	I ² C/HDQ	15	SHA-1	-40 to 85	1.45
bq2028	HDQ	12	ID number	-40 to 85	1.10
bq40z50	SMB	32	SHA-1	-40 to 85	3.45

*Suggested resale price in U.S. dollars in quantities of 1,000.

Battery Management Products

Battery (Li-Ion) Protection Solutions

Design Factors

Number of Series Cells — A battery pack is constructed from a string of series and parallel cells. Each series cell, or group of parallel cells, requires protection from overcharge, overdischarge and short-circuit conditions.

Threshold Voltage — Li-Ion and Li-Polymer cells are produced by many manufacturers. Some manufacturers' technologies create cells of different maximum stress voltages, otherwise

known as the overvoltage threshold. This data is available from the cell supplier.

Threshold Tolerance — The overvoltage threshold has a tolerance to be accounted for in the design for safety reasons.

Shutdown Current — In battery pack applications, constant current draw needs to be very low to preserve battery life.

Charge/Discharge Current — The pass element associated with each protection IC is rated for maximum current whether it be an internal or external FET.

Features

- BiCMOS process results in low current consumption
- Different overvoltage thresholds allow one design to work with several cell suppliers
- Sleep current consumption of less than 3.5 μA enables extended battery life
- 50 mV precision internally trimmed thresholds maximize safety
- Short-circuit protection eliminates the need for an external fuse

Single-Cell Primary Protector

bq29700

The bq297xy battery cell protection device provides an accurate monitor and trigger threshold for overcurrent protection during high discharge/charge current operation or battery overcharge conditions.

Key Features

- VSS 0.3-V to 12-V input voltage range pack+
- Control external charge and discharge FETs
- Voltage sensing across external FETs for overcurrent protection within ± 5 mV (typical)
- Power delivery interruption during fault condition using FET control circuitry (COUT/DOUT output)
- Zero voltage charging for depleted battery
- Low current consumption = 4 μA (typical)

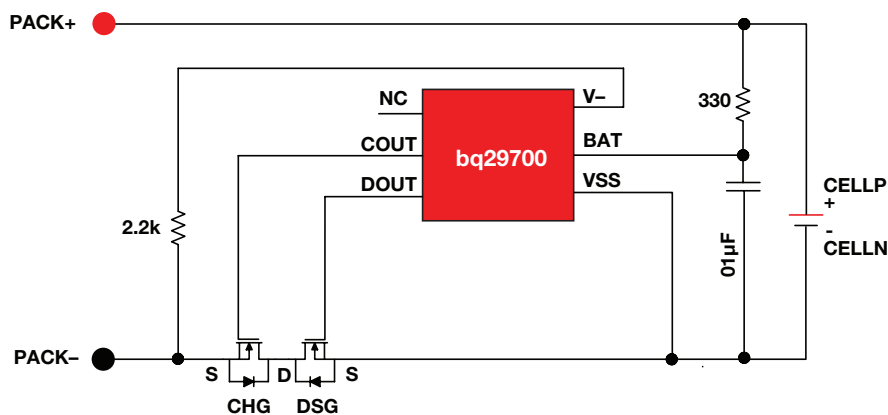

Get more information: www.ti.com/product/bq29700

Selection Guide

Device	Number of Series Cells	Other Features	Package(s)	Price*
bq29200	2	Voltage protector with cell balancing	8-pin SON	0.30
bq2945xx	2 to 3	Voltage protector with internal pre-programmed delay timer	6-pin SON	0.40
bq2946xy	1	Overvoltage safety for chemical fuse activation	6-pin SON	0.38
bq29700	1	Voltage and current protector with low-side NFET drive	6-pin SON	0.26
bq771600	2 to 4	Voltage protector with capacitor-programmed delay timer	8-pin QFN	0.51
bq771800	2 to 5	Voltage protector with internal pre-programmed delay timer	8-pin QFN	0.79

*Suggested resale price in U.S. dollars in quantities of 1,000.

New devices are listed in bold red.

Battery Management Products

Wireless Power

A wireless power system consists of a transmitter (charging pad) and a receiver (mobile device). Both contain a coil and electronics. Power is transferred wirelessly between the coils via inductive coupling. These systems are typically used for charging batteries in mobile devices, or powering subsystems.

Design Factors

Coil System – There are many types of coil systems. The specific type of coil system is dependent on the wireless power standard being used. Usually, the coil system consists of the coil and a magnetic shield to localize the magnetic field.

Interoperability – Compliance to a particular standard ensures that devices can be used with compatible devices from different manufacturers. Certain applications may not need to conform to a standard. TI's wireless power solutions can be used to design compliant as well as non-compliant solutions.

Power Requirements – Requirements for power vary from one mobile device to another. Most handheld consumer devices need between 1 and 5 W for operation. TI has multiple solutions to meet these power levels. Usually, the particular standard selected also dictates the power level allowed to be transferred.

Communication and Control – To safely control power transfer, it is critical that a communication scheme between the transmitter and receiver is built-in.

Communication of control and status includes data such as the amount of power to send, start power transfer and stop power transfer. This communications data is exchanged through the same coils that couple the power.

High Level of Integration – In space-constrained applications, a high level of integration is required. TI's transmitter and receiver solutions are very highly integrated with small footprints.

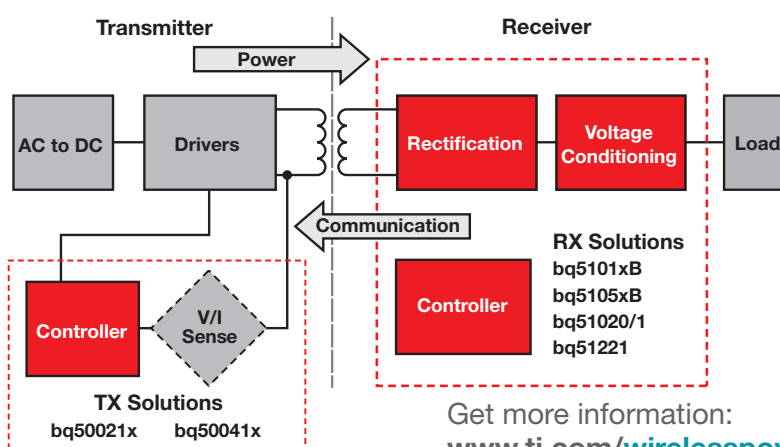

Receiver-Side Solutions

TI's Qi-compliant receivers integrate a low-impedance, full synchronous rectifier, a low-dropout regulator (LDO), digital control and accurate voltage and current loops. The entire power stage (rectifier and LDO) utilize low-impedance NMOS FETs to ensure high efficiency and low power dissipation.

Selection Guide

Device	Standard	Output Current (A)	Output Voltage (V)	Function	V _{IN} Absolute Max (V)	Control Interface	Integrated FET	Temperature Monitor	Package	Chip Scale (mm)	EVM	Comments	Price*
Wireless Power Receivers													
bq51003	WPC v1.1	0.5	5	Power Supply	20	Stand Alone	Yes	Yes	CSP	3x2x0.5	✓	2.5-W WPC v1.1 receiver solution for wearable applications	1.30
bq51013B	WPC v1.1	1	5	Power Supply	20	Stand Alone	Yes	Yes	QFN	3x2x0.5	✓	5-W WPC v1.1 receiver solution	1.50
bq51050B/51B	WPC v1.1	1	4.2/4.35	Battery Charger	20	Stand Alone	Yes	Yes	QFN	3x2x0.5	✓	5-W direct battery charger, WPC v1.1 receiver solution	1.90
bq51010B	WPC v1.1	1	7	Power Supply	20	Stand Alone	Yes	Yes	QFN	3x2x0.5	✓	5-W WPC v1.1 receiver solution with 7-V outputs for reduced power loss	1.70
bq51020	WPC v1.1	1.5	Adj (4-8)	Power Supply	20	Stand Alone	Yes	Yes	CSP	3.6x2.9x0.5	✓	High-efficiency, 5-W WPC v1.1 receiver solution with adjustable output voltage	2.50
bq51021	WPC v1.1	1.5	Adj (4-8)	Power Supply	20	I ² C	Yes	Yes	CSP	3.6x2.9x0.5	✓	High-efficiency, 5-W WPC v1.1 receiver solution with adjustable output voltage and I ² C control	2.60
bq51221	WPC v1.1/ PMA	1.5	Adj (4-8)	Power Supply	20	I ² C	Yes	Yes	CSP	3.6x2.9x0.5	✓	Dual-mode, high-efficiency, 5-W WPC v1.1 and PMA receiver solution	3.00
bq51025	WPC v1.1	2	Adj (4.5-10)	Power Supply	20	I ² C	Yes	Yes	–	3.6x2.9x0.5	✓	Low WPC v1.1 receiver to be used with the bq500215	4.00

*Suggested resale price in U.S. dollars in quantities of 1,000.

New devices are listed in **bold red**.
Preview devices are listed in **bold teal**.

Battery Management Products

Wireless Power

Dual-Mode/WPC, 5-W Single-Chip Wireless Power Receiver

bq51221, bq51021, bq51020

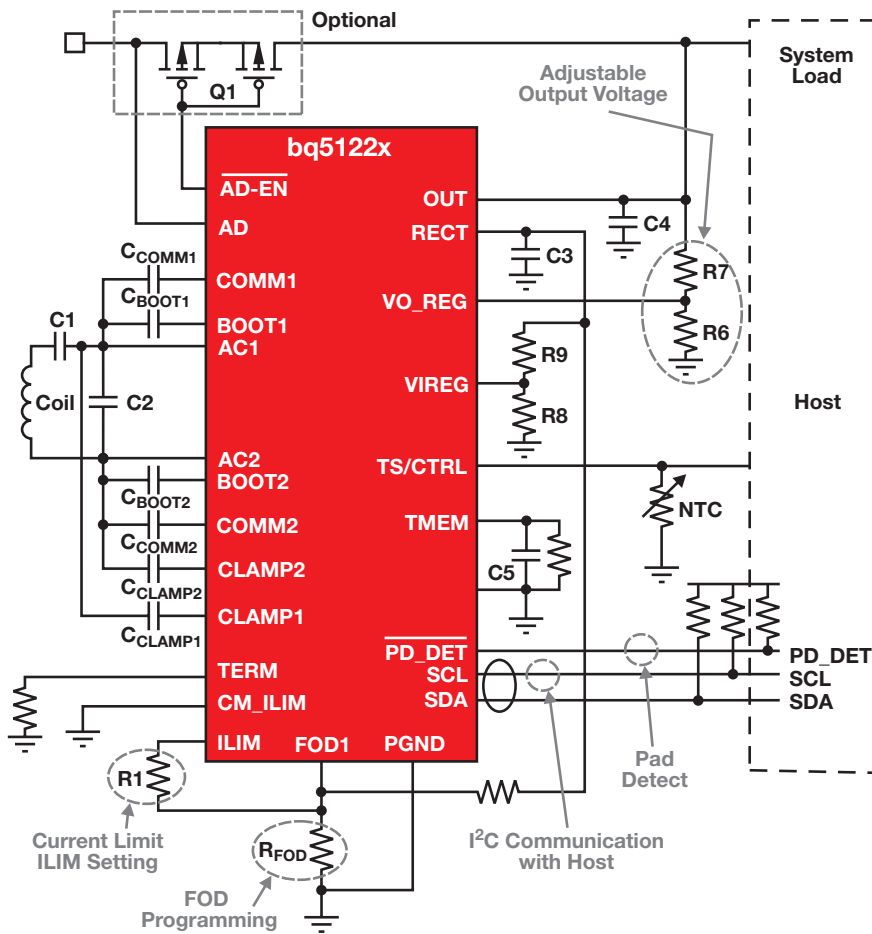

Key Features

- WPC v1.1 compliant receivers (bq51221 receiver is also PMA compliant and automatically switches to correct protocol in dual-mode)
- 5-W operation ensures faster charging and minimizes heat loss
- Adjustable output voltage (4.5 to 8 V) allows output to be optimized to the system to reduce power dissipation
- Linear versus switching post regulator means a large external inductor is not needed
- Pad-detect feature improves user experience
- I²C interface adds design flexibility and provides unique features such as programmable current limit
- Smallest solution size for 5-W system allows all electronics to fit into less than 75 mm²
- bq51020 and bq51021 are WPC-only versions of this device
- Package: 3.6x2.9x0.5-mm CSP

Applications

- Smartphones
- Tablets and headsets
- Wi-Fi hotspots
- Power banks
- Other handheld devices

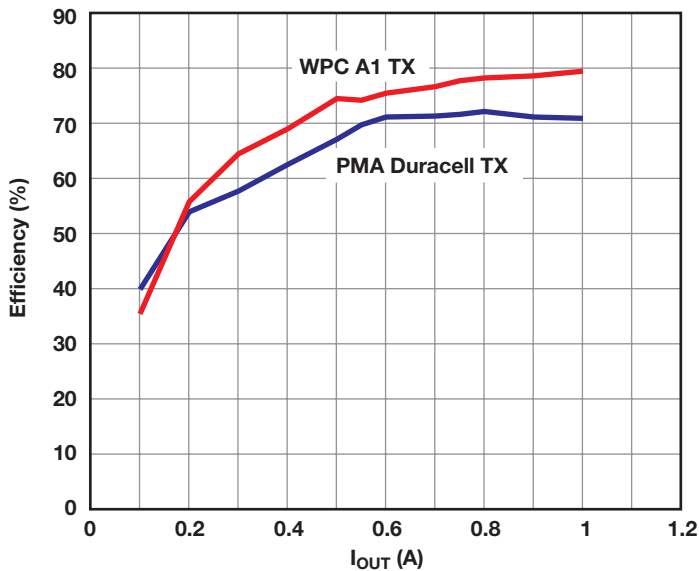

bq51221 WPC and PMA efficiency for dual-mode implementation.

Get more information: www.ti.com/product/bq51221, www.ti.com/product/bq51021 or www.ti.com/product/bq51020

www.ti.com/tool/bq51221EVM-520 or www.ti.com/tool/bq51020EVM-520

Battery Management Products

Wireless Power

Transmitter-Side Solutions

TI offers dedicated digital controllers that integrate the logic functions required to control wireless power transfer in a single-channel, WPC-compliant, contactless-charging base station. These intelligent controllers periodically ping the

surrounding environment for available devices to be powered, monitor all communication from the device being wirelessly powered, and adjust power applied to the transmitter coil per feedback received from the powered device. They also monitor transfer

efficiency with real-time analysis to protect the controllers and receivers from excessive power loss and heat associated with foreign-object detection placed in the power-transfer path.

Qi-Compliant, 5-V Wireless Power Transmitter Manager

bq500212A

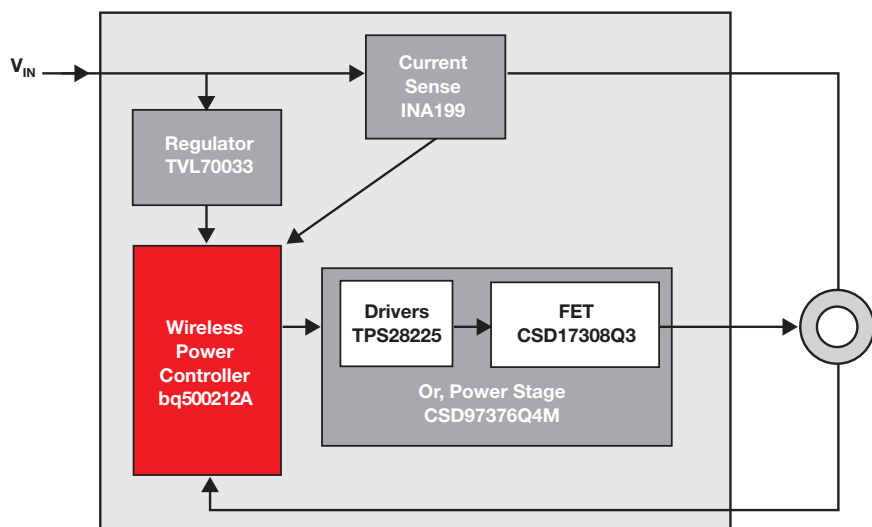

Key Features

- Proven, Qi-certified value solution for transmit-side applications
- Lowest component count for full WPC v1.1 compliance
- 5-V operation conforms to Wireless Power Consortium (WPC v1.1) type A5 or A11 transmitter specification
- Fully Qi-compliant, including improved foreign-object detection (FOD) method
- Permits X7R resonant capacitors for reduced cost
- Dynamic Power Limiting™ for USB and limited source operation
- Digital demodulation reduces components
- LED indication of charging state and fault status
- 7 x 7-mm, 48-pin QFN package

Applications

- WPC v1.1 compliant wireless chargers for:
 - Qi-certified smartphones, handhelds, and accessories
 - Accessories for cars and other vehicles

Get more information: www.ti.com/product/bq500212A

Selection Guide

Device	Standard	Coil Type	Number of Coils Supported	V _{IN} (V)	Power (W)	Dynamic Power Limit	Automotive Qualified	Comments	Price*
Wireless Power Transmitters									
bq500210	WPC v1.0	A1/A10	1	19	5	No	No	WPC v1.0 transmitter solution for 19-V systems	1.90
bq500212A	WPC v1.1	A5/A11	1	5	5	Yes	No	Latest WPC v1.1, 5-V transmitter with reduced BOM and improved, simplified FOD	2.00
bq500412	WPC v1.1	A6	1,2,3	12	5	Yes	No	Latest WPC v1.1, A6 transmitter with reduced BOM and improved, simplified FOD	2.10
bq500414Q	WPC v1.1	A6	1,2,3	12	5	No	Yes	AEC-Q100-qualified A6 transmitter for automotive applications	3.40
bq500215	WPC v1.1	A29	1	12	5	No	No	WPC v1.1 receiver to be used with the bq51025	4.00

*Suggested resale price in U.S. dollars in quantities of 1,000.

New devices are listed in **bold red**.
Preview devices are listed in **bold teal**.

Battery Management Products

Wireless Power

Wireless Power Development Modules

Reduce the design cycle of wireless power solutions and get to market faster with TI's wide range of TX, RX evaluation modules. Whether implementing wireless charging within an existing design, or adding it to a new one, we've got the tools, support and expertise to help you. Two of the available evaluation modules are shown below.

WPC v1.1 Compliant, 5-V Low-Cost Wireless Power Transmitter Evaluation Module

bq500212AEVM-550

The bq500212AEVM-550 evaluation module provides all major functions for evaluation of the bq500212A device in a fully functional WPC v1.1-compliant A5 and A11 wireless transmitter.

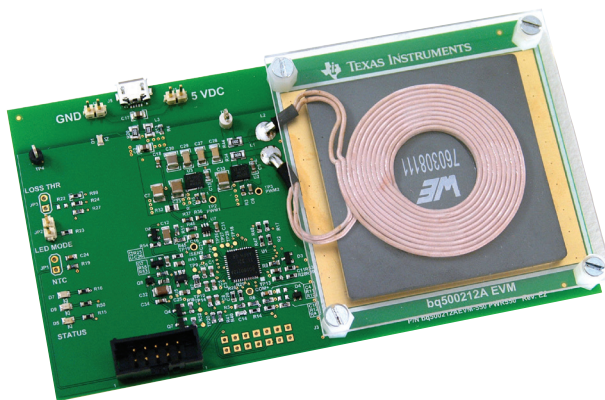

Key Features

- Uses low-cost X7R resonant capacitors
- Reduced BOM components and cost
- Accepts 5 V from power supply or micro-USB cable

Get more information: www.ti.com/tool/bq500212AEVM-550

WPC v1.1 Compliant, Integrated Wireless Power Receiver Evaluation Module

bq51013BEVM-764

The bq51013BEVM-764 wireless power receiver evaluation module (EVM) is a high-performance, easy-to-use development tool for the design of wireless power transfer in portable applications. The EVM provides AC/DC power conversion while integrating the digital control required to comply with the communication protocol.



bq51013b evaluation module

Key Features

- Integrated Qi-compliant receiver with a 5-V regulated supply
- Dynamic Rectifier Control™ for improved load transient response
- Supports 20-V maximum input
- Low-power dissipative rectifier over-voltage clamp ($V_{OVP} = 15\text{ V}$)
- Thermal shutdown
- Single NTC/control pin for optimal safety and I/O with host

Get more information at: www.ti.com/tool/bq51013BEVM-764

Design and Development Tools

Resources

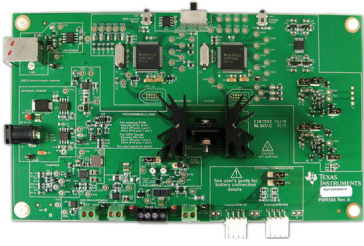

Evaluation Modules

The Battery Management evaluation library consists of an array of boards. Depending on your needs, the list of hardware products has several features to help move forward to production.



Battery Management University

Get technical training from the battery experts to solve your design challenges.

www.ti.com/bmsuniversity



Battery Management Studio

Reduce design time with easy-to-configure Gauge Studio software. The Gauge Studio file size is nearly ten times smaller than TI's previous software to minimize configuration and system firmware development to get your design to market faster.

www.ti.com/bqstudio



Reference Designs

Find trusted reference designs from TI battery experts to help accelerate your time to market.

www.ti.com/tidesigns

Battery Management Quick Search Tool

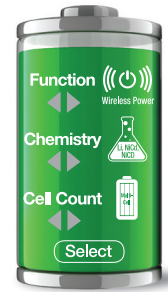

Battery Quick Search

Find your Battery Management parts faster with the easy-to-use Quick Search tool. Search top battery chargers, fuel gauges, and monitors by selecting key system requirements.

www.ti.com/batteryqs



Design Support

Get answers, share knowledge, and solve problems with fellow engineers by accessing the battery charging and gauging forums, blogs, and videos.

www.ti.com/bms-e2e



- Order samples & tools
- Get support on E2E™
- Simulate designs in WEBENCH®
- Set alerts for products & software
- Personalize your web experience

Join today at www.ti.com/myTI

Important Notice: The products and services of Texas Instruments Incorporated and its subsidiaries described herein are sold subject to TI's standard terms and conditions of sale. Customers are advised to obtain the most current and complete information about TI products and services before placing orders. TI assumes no liability for applications assistance, customer's applications or product designs, software performance, or infringement of patents. The publication of information regarding any other company's products or services does not constitute TI's approval, warranty or endorsement thereof.

A021014

Trademarks: The platform bar, Dynamic Rectifier Control, E2E, Impedance Track, my.TI, and MSP430 are trademarks and WEBENCH is a registered mark of Texas Instruments. The *Bluetooth* word mark and logos are owned by the Bluetooth SIG, Inc., and any use of such marks by Texas Instruments is under license. All other trademarks are the property of their respective owners.

IMPORTANT NOTICE FOR TI DESIGN INFORMATION AND RESOURCES

Texas Instruments Incorporated ("TI") technical, application or other design advice, services or information, including, but not limited to, reference designs and materials relating to evaluation modules, (collectively, "TI Resources") are intended to assist designers who are developing applications that incorporate TI products; by downloading, accessing or using any particular TI Resource in any way, you (individually or, if you are acting on behalf of a company, your company) agree to use it solely for this purpose and subject to the terms of this Notice.

TI's provision of TI Resources does not expand or otherwise alter TI's applicable published warranties or warranty disclaimers for TI products, and no additional obligations or liabilities arise from TI providing such TI Resources. TI reserves the right to make corrections, enhancements, improvements and other changes to its TI Resources.

You understand and agree that you remain responsible for using your independent analysis, evaluation and judgment in designing your applications and that you have full and exclusive responsibility to assure the safety of your applications and compliance of your applications (and of all TI products used in or for your applications) with all applicable regulations, laws and other applicable requirements. You represent that, with respect to your applications, you have all the necessary expertise to create and implement safeguards that (1) anticipate dangerous consequences of failures, (2) monitor failures and their consequences, and (3) lessen the likelihood of failures that might cause harm and take appropriate actions. You agree that prior to using or distributing any applications that include TI products, you will thoroughly test such applications and the functionality of such TI products as used in such applications. TI has not conducted any testing other than that specifically described in the published documentation for a particular TI Resource.

You are authorized to use, copy and modify any individual TI Resource only in connection with the development of applications that include the TI product(s) identified in such TI Resource. NO OTHER LICENSE, EXPRESS OR IMPLIED, BY ESTOPPEL OR OTHERWISE TO ANY OTHER TI INTELLECTUAL PROPERTY RIGHT, AND NO LICENSE TO ANY TECHNOLOGY OR INTELLECTUAL PROPERTY RIGHT OF TI OR ANY THIRD PARTY IS GRANTED HEREIN, including but not limited to any patent right, copyright, mask work right, or other intellectual property right relating to any combination, machine, or process in which TI products or services are used. Information regarding or referencing third-party products or services does not constitute a license to use such products or services, or a warranty or endorsement thereof. Use of TI Resources may require a license from a third party under the patents or other intellectual property of the third party, or a license from TI under the patents or other intellectual property of TI.

TI RESOURCES ARE PROVIDED "AS IS" AND WITH ALL FAULTS. TI DISCLAIMS ALL OTHER WARRANTIES OR REPRESENTATIONS, EXPRESS OR IMPLIED, REGARDING TI RESOURCES OR USE THEREOF, INCLUDING BUT NOT LIMITED TO ACCURACY OR COMPLETENESS, TITLE, ANY EPIDEMIC FAILURE WARRANTY AND ANY IMPLIED WARRANTIES OF MERCHANTABILITY, FITNESS FOR A PARTICULAR PURPOSE, AND NON-INFRINGEMENT OF ANY THIRD PARTY INTELLECTUAL PROPERTY RIGHTS.

TI SHALL NOT BE LIABLE FOR AND SHALL NOT DEFEND OR INDEMNIFY YOU AGAINST ANY CLAIM, INCLUDING BUT NOT LIMITED TO ANY INFRINGEMENT CLAIM THAT RELATES TO OR IS BASED ON ANY COMBINATION OF PRODUCTS EVEN IF DESCRIBED IN TI RESOURCES OR OTHERWISE. IN NO EVENT SHALL TI BE LIABLE FOR ANY ACTUAL, DIRECT, SPECIAL, COLLATERAL, INDIRECT, PUNITIVE, INCIDENTAL, CONSEQUENTIAL OR EXEMPLARY DAMAGES IN CONNECTION WITH OR ARISING OUT OF TI RESOURCES OR USE THEREOF, AND REGARDLESS OF WHETHER TI HAS BEEN ADVISED OF THE POSSIBILITY OF SUCH DAMAGES.

You agree to fully indemnify TI and its representatives against any damages, costs, losses, and/or liabilities arising out of your non-compliance with the terms and provisions of this Notice.

This Notice applies to TI Resources. Additional terms apply to the use and purchase of certain types of materials, TI products and services. These include; without limitation, TI's standard terms for semiconductor products (<http://www.ti.com/sc/docs/stdterms.htm>), [evaluation modules](#), and [samples](http://www.ti.com/sc/docs/sampterm.htm) (<http://www.ti.com/sc/docs/sampterm.htm>).

Mailing Address: Texas Instruments, Post Office Box 655303, Dallas, Texas 75265
Copyright © 2017, Texas Instruments Incorporated