

RAILWAY TECHNICAL



RAILWAY SYSTEMS, TECHNOLOGIES AND
OPERATIONS ACROSS THE WORLD

CONTENTS

DESIGN DETAILS OF RAILWAYS, RAILROADS AND METROS.....15

- 1.1. Introduction 15
- 1.2. Deadman 15
- 1.3. Couplers 15
- 1.4. Fully Automatic Couplers 20
- 1.5. Doors 23
- 1.6. Air Conditioning 25
- 1.7. Escalator Steps 26
- 1.8 Escalator Locations..... 28
- 1.9. Suicide Pits 28

ROLLING STOCK AND EQUIPMENTS30

- 2.1. AUXILIARY SYSTEMS ON ROLLING STOCK 30
 - 2.1.1. Introduction 30
 - 2.1.2. On-Board Services 30
 - 2.1.3. Air Equipment 31
 - 2.1.4. The Compressor 31
 - 2.1.5 The Pump 31
 - 2.1.6. Drives 32
 - 2.1.7. Cooling 32
 - 2.1.8. Drying 32
 - 2.1.9. Control..... 32
 - 2.1.10. Synchronisation 32
 - 2.1.11. Storage 33
 - 2.1.12. Distribution 33
 - 2.1.13. Angle Cocks 34
 - 2.1.14. Automatic Couplers..... 34
 - 2.1.15. Air Operated Equipment 34
 - 2.1.16. Traction Equipment..... 35
 - 2.1.17. Doors 35

2.1.18. Air Suspension	35
2.1.19. Driver's Brake Control	35
2.1.20. Pantograph Compressor	35
2.2. ELECTRICAL AUXILIARY EQUIPMENT	37
2.2.1. Introduction	37
2.2.2. On-Board Services	37
2.2.3. High Voltage and Low Voltage Systems	38
2.2.4. Converting HV to LV	38
2.2.5. Development.....	38
2.2.6. Motor Generators	39
2.2.7. Motor Alternators	40
2.2.8. Electronic Auxiliaries	41
2.2.9. Gaps	42
2.3. BOGIE PARTS & DESCRIPTION	44
2.3.1. Introduction	44
2.4. WHEELS AND BOGIES	47
2.4.1. Introduction	47
2.4.2. The Wheel on the Rail	47
2.4.3. Bogies (Trucks)	49
2.4.4. Steerable Bogies.....	49
2.5. VEHICLE SUSPENSION SYSTEMS	51
2.5.1. Introduction	51
2.5.2. Development.....	51
2.5.3. Plate Frame Bogie Primary Suspension.....	52
2.5.4. Plate Frame Bogie Secondary Suspension	53
2.5.5. Cast Steel Bogies	54
2.5.6. Equaliser Bar Suspension	56
2.5.7. Rubber Suspension.....	57
2.5.8. Air Suspension.....	58
2.6. PBL 90 ELECTRO-PNEUMATIC BRAKE CONTROL SYSTEM.....	60

2.6.1. Background	60
2.6.2. Introduction	60
2.6.3. The Parts of the Brake Control Panel	60
2.6.4. Set-up	63
2.6.5. Set-up Complete	63
2.6.6. Release	64
2.6.7. Running	65
2.6.8. Application	66
2.6.9. Maintaining a Constant Brake	67
2.6.10. Partial or Full Release	67
2.6.11. Electro-Pneumatic Assistance	68
2.7. AIR BRAKES.....	69
2.7.1 Introduction	69
2.7.2. Basics.....	69
2.7.3. Operation on Each Vehicle	69
2.7.3. The Principal Parts of the Air Brake System	70
2.7.4 Operation On Each Vehicle	74
2.8. ELECTRICALLY CONTROLLED PNEUMATIC BRAKES	80
2.8.1. Introduction	80
2.8.2. ECP Brakes - Background.....	80
2.8.3. Power Sources.....	81
2.8.4. Manufacturers Systems	81
2.8.5. Benefits	82
2.8.6. Developments	82
2.8.7. ECP Record	83
2.9. ELECTRO-PNEUMATIC BRAKES	84
2.9.1. Introduction	84
2.9.2. Background	84
2.9.3. Principles of the E-P Brake	84
2.9.4. A Simple E-P Brake System.....	85

2.9.5. E-P Application	86
2.9.6. Brake Cylinder Pressure	86
2.9.7. E-P Brake Release	87
2.9.8. E-P Control	87
2.9.9. E-P Variations	88
2.9.10. Self Lapping Brakes	88
2.9.11. Retardation Controller	89
2.9.12. Variable Load Control.....	90
2.9.13. P-Wire Control.....	91
2.9.14. PBL90 System	91
2.10. VACUUM BRAKES	92
2.10.1. Introduction	92
2.10.2. Basics.....	92
2.10.3. Principal Parts of the Vacuum Brake System	93
2.10.4. Operation on Each Vehicle.....	96
2.10.5. Additional Features of the Vacuum Brake	98
2.10.6. Other Vacuum Operated Equipment	100
2.10.7. Vacuum Brakes on Steam Locomotives	100
2.10.8. Comment.....	101
2.11. PASSENGER COACH PARTS.....	102
2.12. ELECTRONIC POWER FOR TRAINS	103
2.12.1. Introduction	103
2.12.2. AC and DC Differences	103
2.12.3. AC Locomotives with DC Drives	104
2.12.4. The Diode	105
2.12.5. The Thyristor	105
2.12.6. SEPEX.....	106
2.12.7. DC Choppers.....	108
2.12.8. Dynamic Braking.....	109
2.12.9. The GTO Thyristor	109

2.12.10. AC Motors	110
2.12.11. The Asynchronous Motor.....	110
2.12.12. AC Drive.....	111
2.12.13. IGBT.....	112
2.12.14. Permanent Magnet Motor	112
2.13. ELECTRIC TRACTION DRIVES.....	113
2.13.1. Introduction	113
2.13.2. The DC Traction Motor: How it Drives the Axle	113
2.13.3. AC and DC Motors	114
2.13.4. Nose Suspended Motor.....	116
2.13.5. Quill Drive.....	117
2.13.6. Monomotor Bogie.....	119
2.13.7. Linear Motor	120
2.14. DIESEL LOCOMOTIVE TECHNOLOGY	122
2.14.1. The Diesel Locomotive	122
2.14.2. Parts of a Diesel-Electric Locomotive	123
2.14.3. Mechanical Transmission	128
2.14.4. Hydraulic Transmission	129
2.14.5. Wheel Slip	130
2.14.6. Diesel Multiple Units (DMUs).....	130
2.14.7. The Diesel Engine	130
2.14.8. Diesel Engine Types.....	131
2.14.9. Size Does Count.....	132
2.14.10. To V or not to V	132
2.14.11. Tractive Effort, Pull and Power	133
2.14.12. Starting.....	133
2.14.13. Governor	134
2.14.14. Fuel Injection.....	135
2.14.15. Fuel Control.....	135
2.14.16. Engine Control Development	136

2.14.17. Power Control	136
2.14.18. Cooling	137
2.14.19. Lubrication	138
2.14.20. Transmissions	138
2.14.21. Diesel-Electric Types	139
2.15. ROLLING STOCK MANUFACTURING	140
2.15.1. Introduction	140
2.15.2. The Process	140
2.15.3. Timescales	140
2.15.4. Design	141
2.15.5. Long Lead Ordering	142
2.15.6. Jigs and Tools	142
2.15.7. Manufacturing Engineering	145
2.15.8. Configuration Control	145
2.15.9. Production Control	146
2.15.10. Materials & Equipment Buying	146
2.15.11. Parts Manufacture	147
2.15.12. Underframe	148
2.15.13. Sides	152
2.15.14. Bodyshell Assembly	152
2.15.15. Underframe Invert	159
2.15.16. Roof	159
2.15.17. Ends	160
2.15.18. Painting	160
2.15.19. Transport	162
2.15.20. Bogie Construction	162
2.15.21. Wheels and Axles	164
2.15.22. Bogie Assembly	166
2.15.23. Wiring	167
2.15.24. Piping	167

2.15.25. Fitting Out	168
2.15.26. Testing	177
2.15.27. Commissioning	178
2.15.28. Delivery	179
2.16. MULTIPLE UNIT OPERATION	183
2.16.1. Introduction	183
2.16.2. Origins	183
2.16.3. The Relay	184
2.16.4. The Contactor	185
2.16.5. Multiple Unit Control	186
2.16.6. Forward and Reverse	187
2.16.7. Modern Control Systems	188
2.17. MULTI-DECK TRAINS	189
2.17.1. Introduction	189
2.17.2. Background	189
2.17.3. The UK Experiment	189
2.17.4. Europe	189
2.17.5. North America	191
2.17.6. Freight	192
2.18. TRAIN MAINTENANCE	194
2.18.1. Introduction	194
2.18.2. Background	194
2.18.3. Maintenance Facilities	194
2.18.4. Access	195
2.18.5. Cleaning and Stabling	195
2.18.6. Toilets	196
2.18.7. Train Washing Machines	197
2.18.8. Wheel Lathe	198
2.18.9. Leaves on the Line	201
2.18.10. Inspection Sheds	202

2.18.11. Shore Supplies	203
2.18.12. Lifting.....	207
2.18.13. Maintenance Workshops	211
2.18.14. Maintenance Programmes.....	212
2.18.15. Failures	213
2.18.16. Performance Measures	214
2.18.17. The Development of Train Maintenance	215
2.19. WHEEL ARRANGEMENTS.....	217
2.19.1 Introduction	217
2.19.2. Modern Diesel and Electric Locomotives	217
2.19.3. Older Designs	219
2.19.4. Steam Locomotives	220
TRAIN OPERATIONS.....	221
3.1. Introduction	221
3.2. Definitions	221
3.3. The Objective	221
3.4. Locomotive Hauled Trains.....	222
3.5. Terminal Operations	222
3.6. Multiple Unit Operation	223
3.7. Push-Pull Operation	224
3.8. High Speed Multiple Units.....	225
3.9. Headway.....	225
3.10. Terminals, Loops and Turnbacks	226
3.11. Train Service Planning	228
3.12. Round Trip Time	229
3.13. Train Loading.....	230
3.14. Rolling Stock Calculations.....	230
3.15. Rolling Stock Operation.....	231
3.16. Stock Balance	231
3.17. Working Timetable.....	232

3.18. Timekeeping	232
3.19. Recovery Time	233
3.20. Terminal Occupation	233
3.21. Stepping Back	234
3.22. Double-Ending	234
3.23. Crew names	235
3.24. Crew Hours And Numbers	236
4. SIGNALLING PAGES INDEX	238
4.1. Introduction	238
4.2. THE DEVELOPMENT AND PRINCIPLES OF UK SIGNALLING	238
4.2.1. Introduction	238
4.2.2. Background	238
4.2.3. Pioneer Signalling	238
4.2.4. The Time Interval System	239
4.2.5. Line Capacity	239
4.2.6. Fixed Signalling	239
4.2.7. Distant Signals	240
4.2.8. Interlocking	240
4.2.9. Blocks	241
4.2.10. The Track Circuit	241
4.2.11. Track Circuit - Block Unoccupied	242
4.2.12. Track Circuit - Block Occupied	243
4.2.13. Multi-Aspect Signals	243
4.2.14. Four-Aspect Signalling	244
4.2.15. A Safe Braking Distance	245
4.2.16. The Overlap	245
4.3. TRAIN PROTECTION IN THE UK	247
4.3.1. Background	247
4.3.2. AWS - Automatic Warning System	247
4.3.3. Enforcement	249

4.3.4. TPWS	249
4.3.5. What TPWS Does	251
4.3.6. What TPWS Does Not Do	251
4.3.7. ATP (Automatic Train Protection) or TPWS.....	252
4.3.8. ERTMS	252
4.3.9. Comment.....	252
4.4. BRITISH SIGNALLING - WHAT THE DRIVER SEES.....	254
4.4.1. Introduction	254
4.4.2. Semaphore Signals	254
4.4.3. Semaphore Signal Parts.....	254
4.4.4. Types of Semaphore Signal	255
4.4.5. Junction Signals	257
4.4.6. Subsidiary Signals	258
4.4.7. Colour Light Signals	259
4.4.8. 4-Aspect Operating Sequence	260
4.4.9. Route Signalling.....	260
4.4.10. Modern Shunt Signal	262
4.4.11. Some Photos	262
4.5. METRO SIGNALLING	264
4.5.1. Introduction	264
4.5.2. The Overlap	265
4.5.3. Track-Circuited Overlaps	266
4.5.4. Absolute Block.....	267
4.5.5. Automatic Train Protection.....	268
4.5.6. ATP Speed Codes.....	268
4.5.7. Operating with ATP	269
4.5.8. Distance-to-Go	270
4.5.9. Speed Monitoring.....	271
4.5.10. Operation with Distance-to-Go.....	271
4.6. ATP BEACONS AND MOVING BLOCK.....	273

4.6.1. Introduction	273
4.6.2. ATP Code Transmission	273
4.6.3. Beacon Transmission.....	274
4.6.4. Operation With Beacons	275
4.6.5. Intermittent Updates	276
4.6.6. Moving Block - The Theory.....	276
4.6.7. Moving Block and Radio Transmission	277
4.6.8. Moving Block - Location Updates.....	278
4.6.9. An Early Moving Block System	279
4.6.10. Moving Block - Why Do We Need It?	279
4.7. AUTOMATIC TRAIN OPERATION	281
4.7.1. ATO.....	281
4.7.2. Metro Station Stops	281
4.7.3. Multi Home Signalling - Approach.....	283
4.7.4. Multi Home Signalling - Run In.....	283
4.7.5. ATO/ATP Multi Home Signalling.....	284
4.7.6. ATO Docking and Starting	284
4.8. AUTOMATIC TRAIN CONTROL (ATC)	286
4.8.1. Introduction	286
4.8.2. Definition of ATC	286
4.8.3. The ATC Package	286
4.8.4. Moving Block.....	288
4.9. ROUTE SIGNALLING.....	289
4.9.1. Junctions	289
4.9.2. Route and Track Locking	289
4.9.3. Signals at Junctions	290
4.9.4. Interlocking	291
4.9.5. Route Signalling - The Signalman's Display	291
4.9.6. Route Set-up	292
4.9.7. Train Movement Sequences	293

4.10. SINGLE LINE OPERATION	299
4.10.1. Introduction	299
4.10.2. One Engine In Steam	299
4.10.3. Single Line Operation in the US.....	299
4.10.4. The Timetable	300
4.10.5. Train Speed Rules (US)	300
4.10.6. Train Spacing	300
4.10.7. Train Orders	300
4.10.8. Track Warrants.....	301
4.10.9. Unsignalled Operations in the US	302
4.10.10. Centralised Traffic Control (CTC).....	302
4.10.11. Single Line Operation (UK)	302
4.10.12. Staff and Ticket System	303
4.10.13. Electric Token Block	303
4.10.14. Radio Electronic Token Block (RETB).....	304
4.11. US RAILROAD SIGNALLING	306
4.11.1. Basic Differences (UK-US):	306
4.11.2. US Signal Layouts	308
4.11.3. Precedence.....	309
4.11.4. Train Orders and Track Warrants.....	309
4.11.5. Signalling Commands	309
4.11.6. Interlocking Signals	310
4.11.7. Types of Signals	312
4.11.8. The Imposition of ATS/ATC	314
4.11.9. Types of ATS/ATC	314
5. RAILWAY STATION DESIGN	317
5.1. Introduction	317
5.2. Background	317
5.3. Station and Crossing Safety.....	317
5.4. Platforms	318

5.5. Platform Screens and Doors.....	319
5.6. Entrances and Exits	321
5.7. Passenger Information	323
5.8. Toilets.....	325
5.9. Concessions.....	325
5.10. Station Design	326
5.11. Side Platform Station	326
5.12. Island Platform Station.....	327
5.13. Elevated Station with Side Platforms	328
5.14. Elevated Station with Ticket Hall Below Platforms	328
5.15. Lifts and Escalators.....	329
5.16. Examples of Good Station Design Features	330
6. INFRASTRUCTURE	332
6.1. Introduction	332
6.2. Background	332
6.3. Basic Construction.....	332
6.4. The Sub-Structure	333
6.5. Ballast.....	334
6.6. Track.....	334
6.7. Sleepers (Ties)	334
6.8. Rail.....	337
6.9. Rail Welding	340
6.10. Gauge	340
6.11. Modern Track Forms	341
6.12. Ballasted vs Non-Ballasted Track	341
6.13. Structures.....	342
6.14. Gauging	343
6.15. Monuments and Datum Plates	343
6.16. Curves.....	343
6.17. Cant	344

6.18. Turnouts	344
6.19. Crossings	345
6.20. Types of Turnouts.....	346
6.21. Examples of Turnouts.....	347
7. GLOSSARY	351
7.1. TRAIN BRAKING GLOSSARY	351
7.2. ELECTRIC LOCOMOTIVE GLOSSARY	376
7.2.1. Introduction	376
7.2.2. Electric Locomotive Parts.....	376
7.3. STEAM GLOSSARY	384

DESIGN DETAILS OF RAILWAYS, RAILROADS AND METROS

1.1. INTRODUCTION

There are many parts of the railway business which are interesting in their own right and which questions are asked about from time to time.

1.2. DEADMAN

During the last decade of the 19th century, trains powered by electricity began to appear. Since there was no fire for a fireman to attend, it was logical that only one man was needed in the cab. However, it was thought that there should be some way of ensuring he always kept alert and, indeed, that he always stayed in the cab while the train was running. It therefore became usual to provide some sort of vigilance device.

The vigilance device was originally installed to cover the situation where a driver collapsed due to illness whilst in charge of a train and it usually consisted of a spring loaded power controller handle or button. It therefore quickly became known as the "deadman's handle". More recently it has become known as a vigilance device or "driver's safety device" (DSD). In France it is called "VACMA", short for "Veille Automatique de Contrôle à Maintien d'Appui".

There are three types of deadman devices; a spring loaded master controller handle, a spring loaded pedal or an "alerter". The deadman's handle usually requires constant pressure to maintain operation. If the handle is released, the brakes will apply. The pedal requires operation at regular intervals. One minute seems to be the normal time allowed between pedal depressions. An audible "warble" warns the driver that he must depress the pedal within 3 seconds. For an "alerter", the key thing is positive movement of the controls: if you don't move something occasionally, the alerter will come on and you have to acknowledge it. If not, it will cause a penalty brake application. This is the popular system in the US. In some countries, a push button is provided in place of the alerter system.

French railways used to favour a ring fitted round the controller handle. You have to grip the ring and lift it against spring pressure to keep the brakes off. There is a time delay, essential as most of the driving positions are in the centre of the cab away from the side windows. Of course, you need to look out of the side window sometimes for shunting, coupling and so on. It's not much good if you can't hold on to the "deadman" and there's no time delay.

1.3. COUPLERS

In order for two railway vehicles to be connected together in a train they are provided with couplers. Since there are a large number of railway vehicles which might have to be

coupled at one time or another in their lives, it would seem sensible to ensure that the couplers are compatible and are at a standard position on each end of each vehicle. Of course, life isn't as simple as that, so there are a variety of different couplers around. However, there is a high degree of standardisation and some common types have appeared around the world.

Link and Pin

The simplest type of coupler is a link and pin. Each vehicle has a bar attached to the centre of the headstock (the beam across the end of the vehicle, variously called the end sill or pilot in the US) which has a loop with a centre hole attached to it. Each coupler has a bellmouth around the end of the bar to assist in guiding the bar with the hole into place. The loops are lined up and a pin dropped into them. It's not very sophisticated but it was used for many railways during the 19th century and has persisted on a few remote lines to this day. The narrow gauge Ali Shan Railway in Taiwan is one such line.

Bar

The next type of coupler is the bar coupler. This is what is known as a semi permanent coupler. It cannot be disconnected unless the train is in a workshop and access underneath the train is available. It is normally used in EMUs which are kept in fixed formations of two, three or four cars. The bar couplers are located within the unit, while the outer ends of the unit have some type of easily disconnected coupler. Bar couplers are simple, just consisting of a bar with a hole at the inner ends through which the car body is connected by a bolt. Others consist of two halves which are just bolted together as shown in this example:



Two cars of a metro EMU unit used in Lyons, France coupled with a bar coupler. This type is bolted in the centre, other types are solid with a removable connection under the car body. The electrical and pneumatic connections are carried in the cables hanging under the coupler bar.

Link Coupling:

This type of coupling is exactly what it says a set of three links which are hung from hooks on each vehicle. A development of this is the "Instanter" coupler, which has a middle link forged into a triangular shape to allow the distance between vehicles to be (crudely) adjusted. This is to allow the side buffers used with the coupler to be adjacent to each other and provide some degree of slack cushioning.

The coupler required a person to get down on the track between the two vehicles and lift the coupling chain over the hook of the other vehicle. Sometimes a "coupling pole" was used for quickly uncoupling freight wagons.

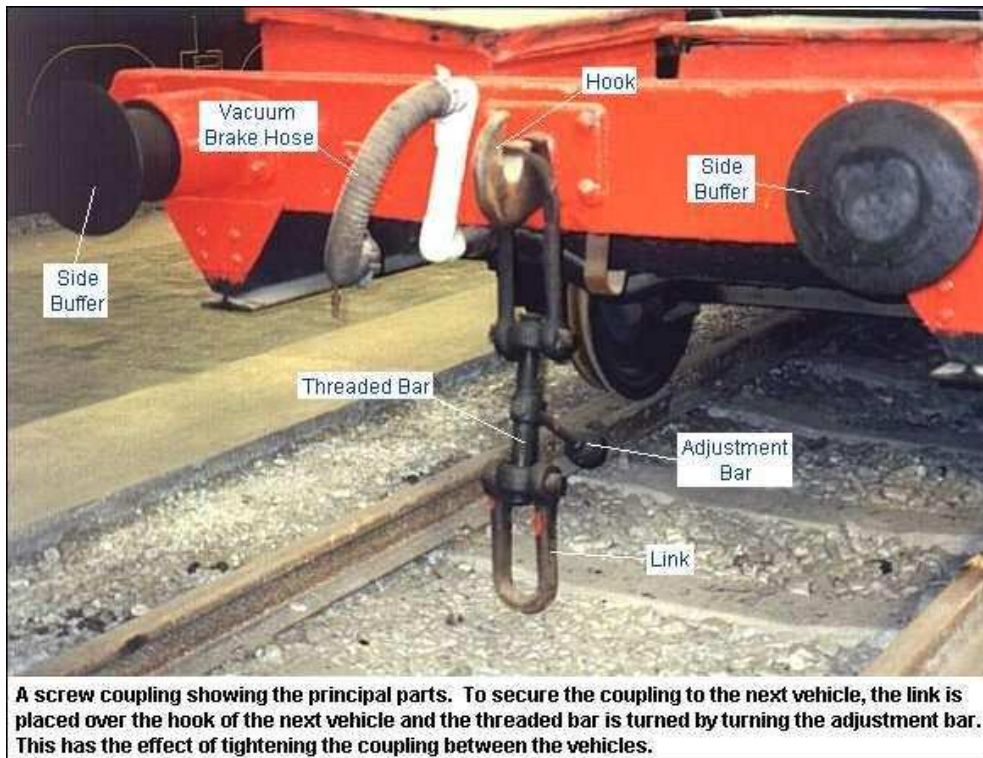

This photo shows a screw coupler in the uncoupled position. This is a development of the 3-link coupling where the middle link is replaced by a screw. The screw is used to tighten the coupling between the two vehicles so as to provide for cushioning by compressing the side buffers. The following photos show typical screw couplings.

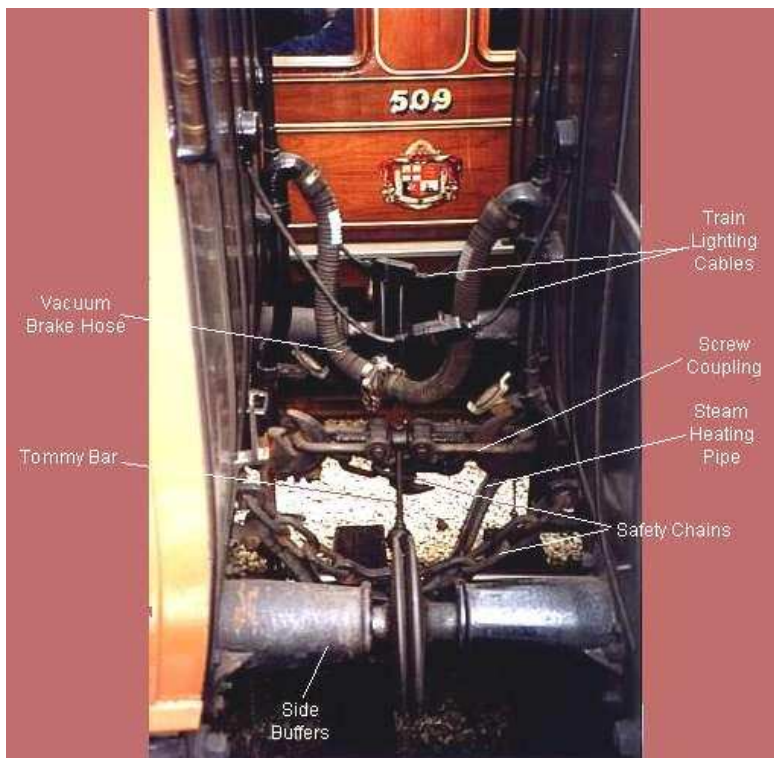

The photo on the left shows a coupled screw coupler also showing typical fittings of passenger vehicle coupling. In addition to the mechanical couplings required to connect the vehicles, trains had to have through connections for brakes, lighting and heating. In this photo, the arrangements for coupling two passenger coaches in a steam hauled train are shown. Note that this particular type of coach was provided with safety chains,

which were fitted in case the main coupling broke. Of course, all the work involved in

connecting the two vehicles was carried out manually. It is hard work and sometimes dangerous. It is still common in the UK and Europe.

Buckeye Coupler

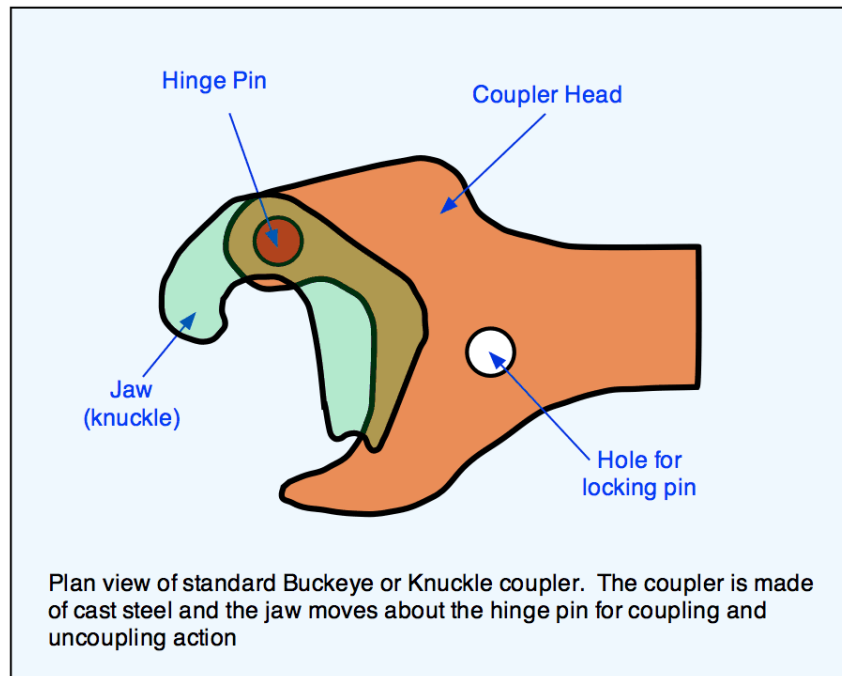

By far the most common coupler seen around the world is known variously as the "Knuckle", "Buckeye" or "Janney" coupler, diagram left. This is an automatic, mechanical coupler of a design originating in the US and commonly used in other countries for both freight and passenger vehicles. It is standard on UK hauled passenger vehicles and on the more modern freight wagons. The term "Buckeye" comes from the nickname of the US state of Ohio "the Buckeye state" and the Ohio Brass Co. which originally marketed the coupler. It was invented in 1879 by a US civil war veteran named Eli Janney, who wanted to find a replacement for the link and pin couplers then standard in the US. Link and pin coupler required staff to stand between cars to couple and uncouple and there were many injuries and even deaths as a result. Janney's invention solved these problems and was taken up by a number of lines. The device eventually became standard when the link and pin coupler was banned by the US government in 1900.

The coupler (shown above) is made of cast steel and consists of four main parts. The head itself, the jaw or knuckle, the hinge pin, about which the knuckle rotates during the coupling or uncoupling process and a locking pin. The locking pin is lifted to release the knuckle. It does this by raising a steel block inside the coupler head which frees the knuckle and allows it to rotate.

The simplified animated diagram below shows the steps when two couplers are being coupled.

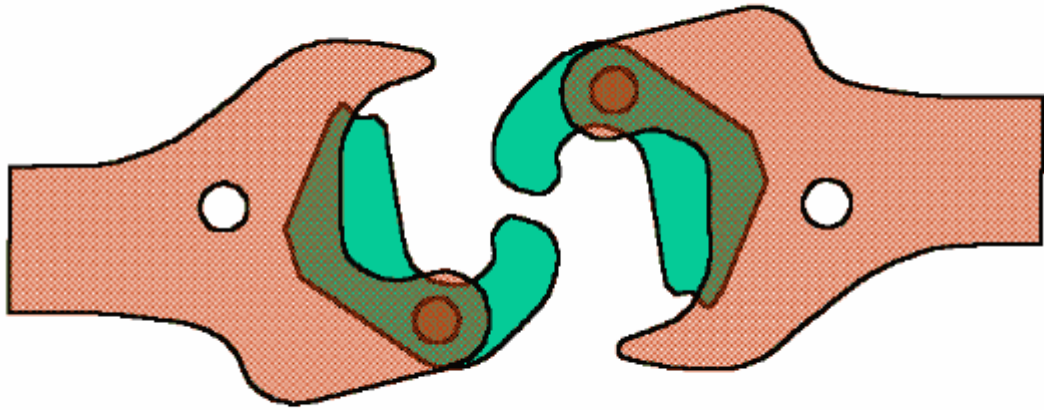

To couple two vehicles, the knuckles must be open. When the two vehicles are pushed together, the knuckles of the two couplers close on each other and are locked from behind by a vertical pin dropping a steel block into place behind a raised casting on the knuckle. To uncouple, one of the pins must be pulled up to release the block locking the knuckle. This is done by operating a lever or chain from the side of the vehicle.

1.4. FULLY AUTOMATIC COUPLERS

More and more railways are using fully automatic couplers. A fully automatic coupler connects the vehicles mechanically, electrically and pneumatically, normally by pushing the two vehicles together and then operating a button or foot pedal in the cab to complete the operation. Uncoupling is done by another button or pedal to disconnect the electrical contact and pneumatic connection and disengaging the coupler mechanically.

Fully automatic couplers are complex and need a lot of maintenance care and attention. They need to be used often to keep them in good working order. There are a number of different designs in use. Two are shown here.

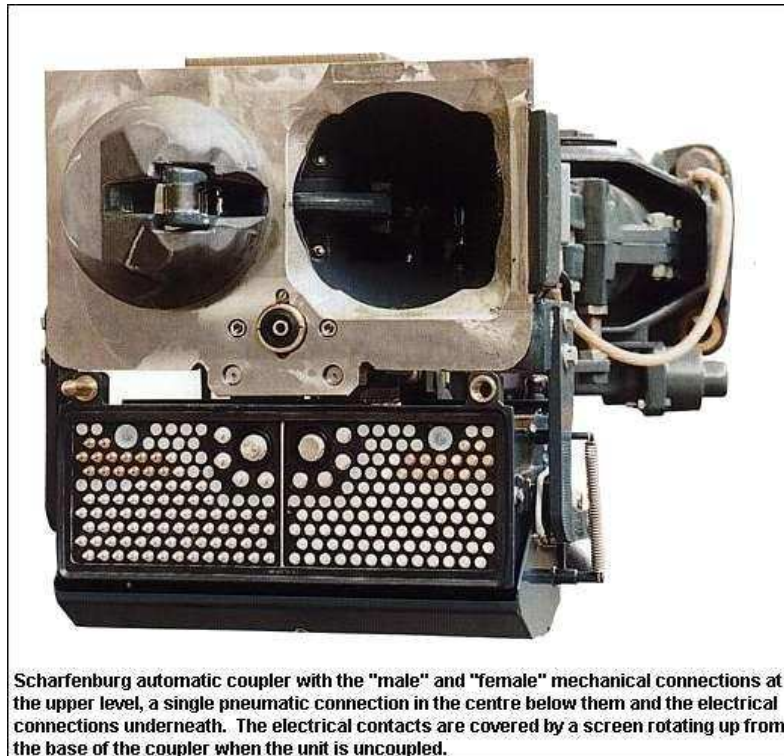

The Scharfenberg automatic coupler is a design widely used on European multiple unit rolling stock of all types, ranging from high speed trains to light rail vehicles. The coupler has a mechanical portion with pneumatic and electrical connections. The units are coupled by pushing one onto the other. The electrical contacts mounted under the mechanical coupler are protected by a cover when uncoupled.

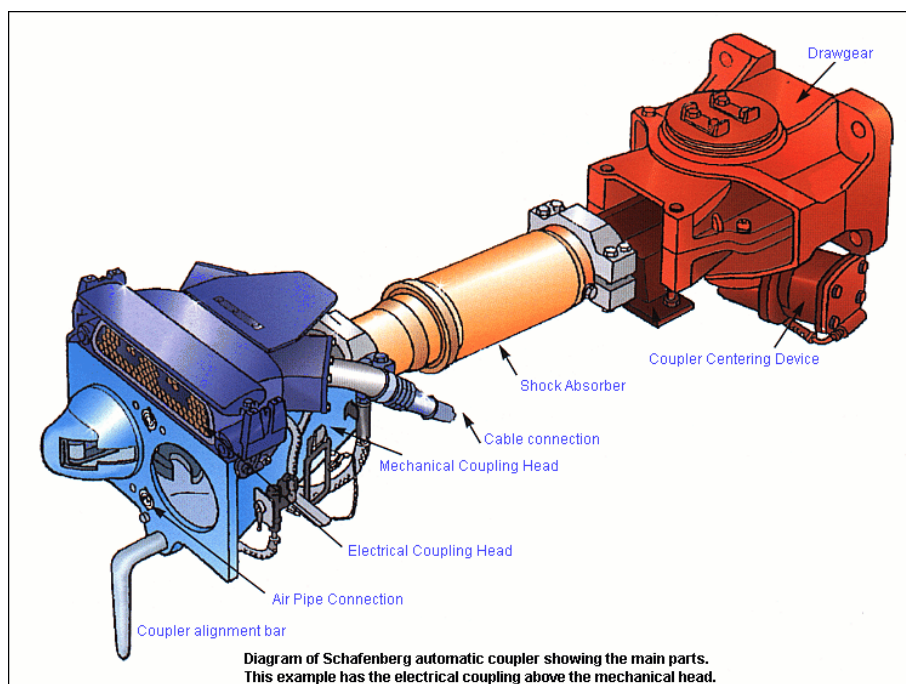

A drawing of another version of the Scharfenberg coupler which has the electric contacts over the coupler. The part names are included in this drawing.

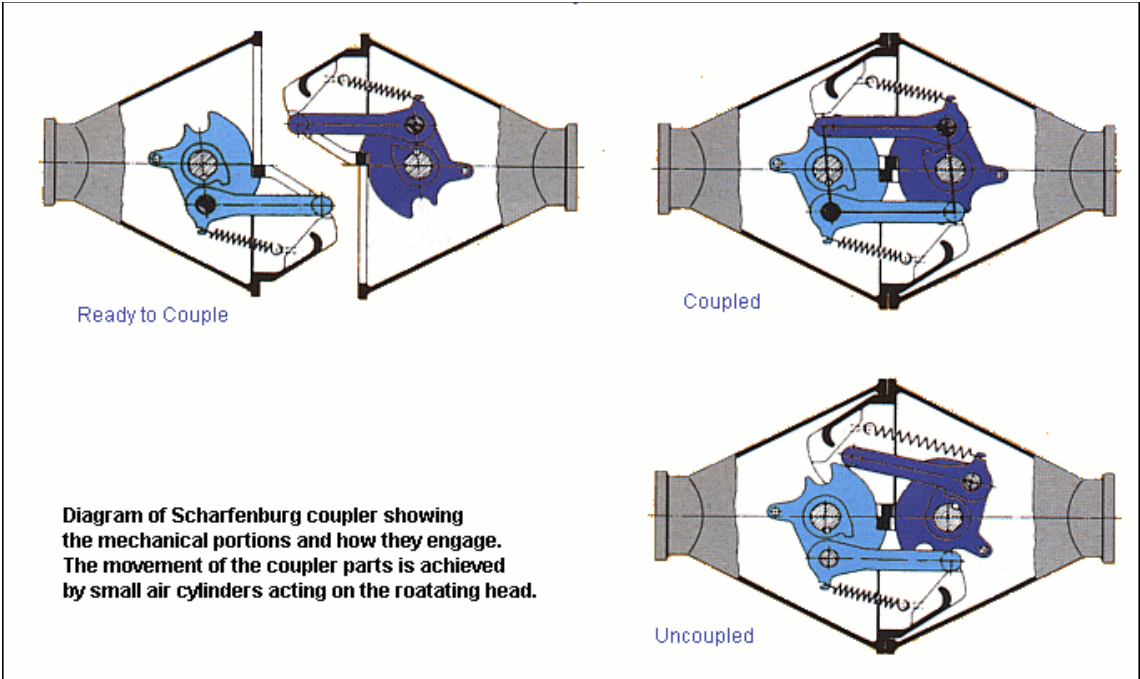

A drawing of the mechanical portion of the Scharfenberg coupler showing how the two couplers engage and uncouple.

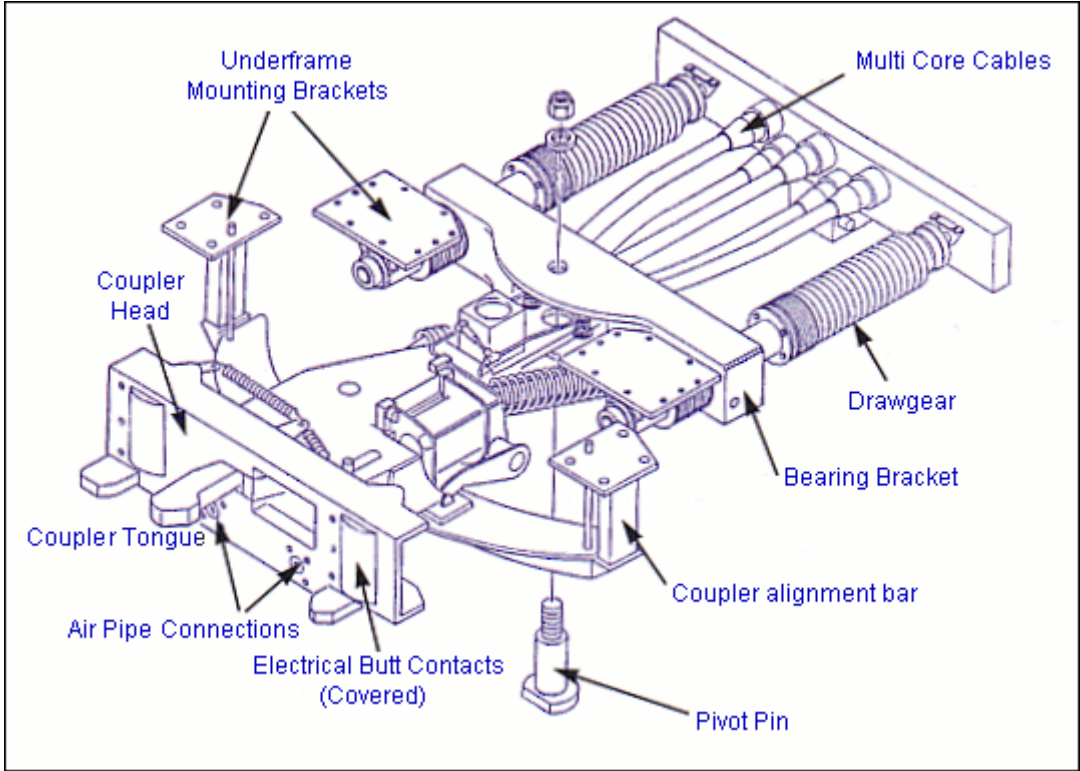

London Underground uses a type of automatic coupler known as the Wedglock. It was first introduced in 1935 and has remained little changed since. It provides full

mechanical, electrical and pneumatic connections. Older versions were fully automatic, being released from a pushbutton in the driver's cab. More recent versions use a hand operated release which has to be operated in each cab. A version of the coupler is also used on the Glasgow Subway.

1.5. DOORS

There is an array of doors in use on rolling stock today. Plug doors, bi-folding doors, slam doors, sliding pocket doors and exterior sliding doors immediately come to mind.



Plug doors are usually found on Light Rail Vehicles (LRVs) but can often be found on heavy rail rolling stock too. These doors are bi-parting, i.e. two leaves open from the middle. When they are opened, the doors 'pop' forward and then swing on a fulcrum arrangement to open out onto the exterior of the vehicle. When the command to close is received, the reverse operation takes place and the doors 'pull' inwards to line up snugly with the side of the bodyshell. There is a rubber edging strip around the doors which forms a seal when in the closed position. This type of door is a maintenance headache with all the moving parts and occasionally unreliable rubber edges. However, it does provide a tight seal and a flush exterior finish which looks good and is easy to clean when passing the vehicle through a car washing machine.

Bi-folding doors are commonest on LRVs and consist of two panels per side of the opening. Some European coaches have bi-folding doors opening one way only. The doors are electrically controlled, either by the driver or by passengers (with a push button). When the command to open is received, the doors fold inwards and the panels will end up parallel to the step well or windscreen. The problem with these doors is that if the

train is full of commuters as the panels swing in they can hit a person standing in this area. They are also very difficult to seal requiring clearance on the underside for the opening motion, which allows the ingress of water either in operation or when passing through the train wash.

Sliding pocket doors are found on all types of rolling stock and, as the name implies, on opening slide into a pocket between the inside of the bodyshell and the interior lining. The lining in this area will usually protrude into the interior to accommodate the door panel. The door panel can be bi-parting or a single leaf. The door operator can be over the doorway or mounted on the floor behind a suitably positioned seat. The maintenance headaches occur particularly with the runner provided along the bottom of the opening to guide the runner for the panels. This becomes blocked with dirt over time causing the doors to jam.



Another type of door is the exterior sliding door or outside hung door and, again, is found on a number of different types of rolling stock. It is a very popular type of door because it is easier to design but most designs suffer from poor aesthetics due to the very visible runner that is on the exterior or the bodyshell for the door(s) to open and close along. Some types of these doors simply slide backwards and forwards on the runners for the opening and closing motion. Usually at the command of the train driver or sometimes at the behest of the passenger. More sophisticated types work in a similar manner to the plug door, first 'popping' out before sliding back on the runner, similarly on the closing cycle 'pulling' back in to the car shell opening.

Slam doors were the standard used for years on British Railways rolling stock but have now been 'outlawed' by the UK Health and Safety Executive and all stock still in service with this type of door must be replaced by 2002. Personally, I do not think this will happen. There are too many of these old vehicles left. The slam door is the traditionally functional, swinging, hinged door that opens manually by the turn of a handle. What more can be said about them?

1.6. AIR CONDITIONING

Most modern passenger vehicles are provided with air conditioning and they will also have heaters in countries where the climate gets cold enough to require it. Here is the basic layout of an air conditioned coach, also equipped with heating equipment.

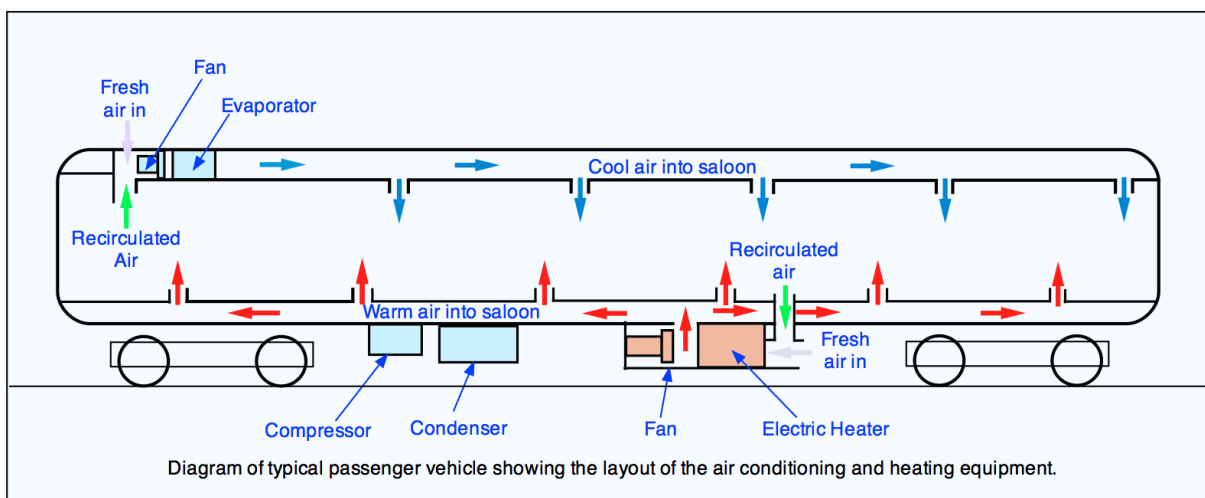

The air conditioner is designed to the so-called "split" arrangement, where the condenser and compressor are mounted under the car floor and the evaporator and fans are mounted in the roof. Sometimes there are two sets in the roof. The coolant from the condenser is passed to the evaporator in the roof through a connecting pipe. On older cars of the New York Subway, these connecting pipes doubled as handrails in the passenger area. They were so cold to touch, you almost got frostbite if you held on to them for too long.

The heater is a separate unit under the car floor, consisting of an electric resistance heater and a fan. Hot air is blown into the car by the fan, having passed through the heater from an underfloor intake. This intake collects some fresh air and uses some recirculating air from inside the car. The same air intake arrangement is provided in the roof for the air conditioning fan in the roof.

Some car heaters on EMU trains use resistance grids heated by the dynamic braking system. Waste energy generated by braking is converted into electric energy by the traction motors and this is fed into the heater grids.

1.7. ESCALATOR STEPS



Escalator at Stratford, London, UK. This looks good but it is a very lightweight design, with glass sidewalls and two flat steps at the landings. It is not ideal for heavy use and the glass will need to be cleaned regularly if it is not to look neglected. Note how the ends of the handrails have to be protected by steel pillars.

Escalators are common in public buildings and railway stations. However, their uses can be quite different in terms of volume and speed. Most escalators seen in stores and office buildings are fairly lightly used and slow speed. This example of a small lightweight escalator as installed at Stratford station, London but those used in railway stations need to be faster and heavier in construction because of the greater volumes of people which use them.



Escalator with four flat steps as fitted to a station on the Bangkok Transit System.

One visible feature of transportation escalators is that more flat steps should be provided at the landings four instead of two, as shown in the photo, left.

The reason for having the larger number of flat steps is to allow people to board and alight from the escalator more quickly. A two-step escalator will cause people to be more cautious because the steps start to rise immediately the passenger boards. A four-step escalator allows people more time to adjust to the movement, so the machine can be run faster and provide increased capacity.

1.8 ESCALATOR LOCATIONS

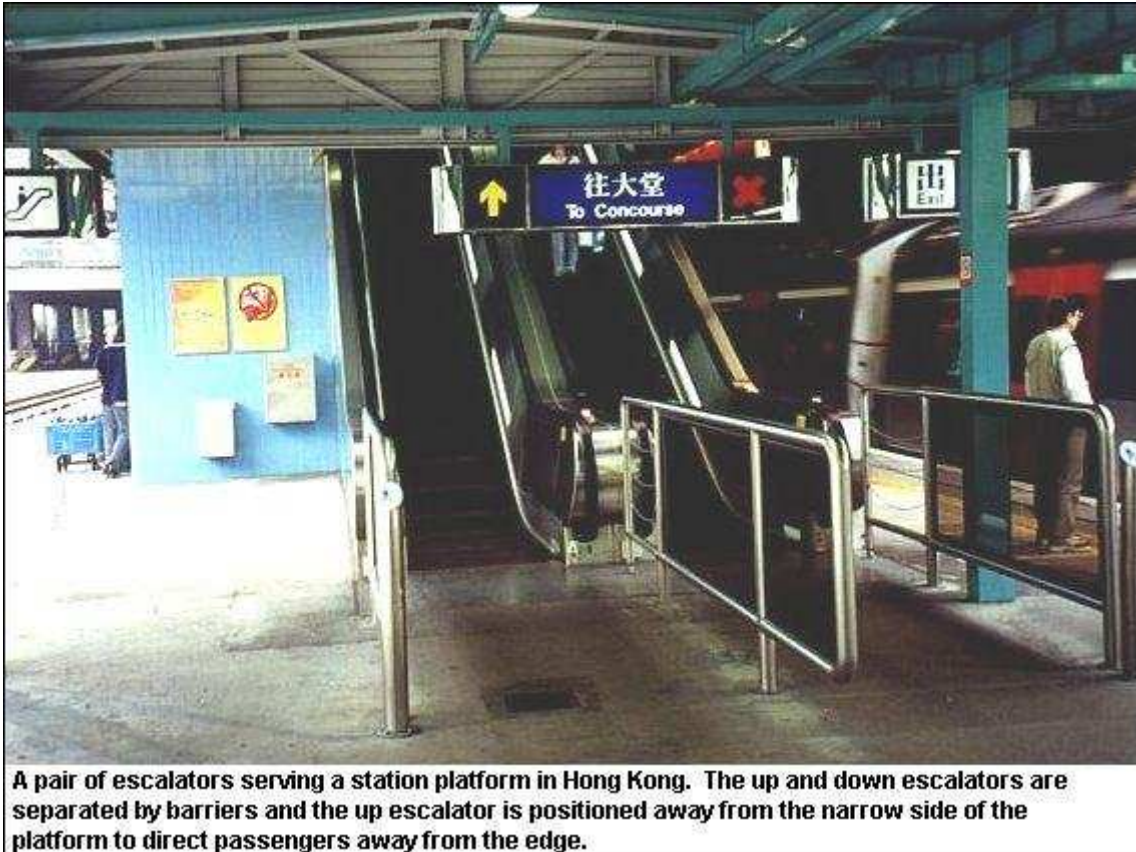

Escalators must be positioned carefully. On high capacity railways, they are important for clearing platforms quickly at peak times when a lot of passengers have arrived on a train and the platform needs to be clear for the next train. Ascending and descending passengers need to be separated and barriers are often provided to help this.

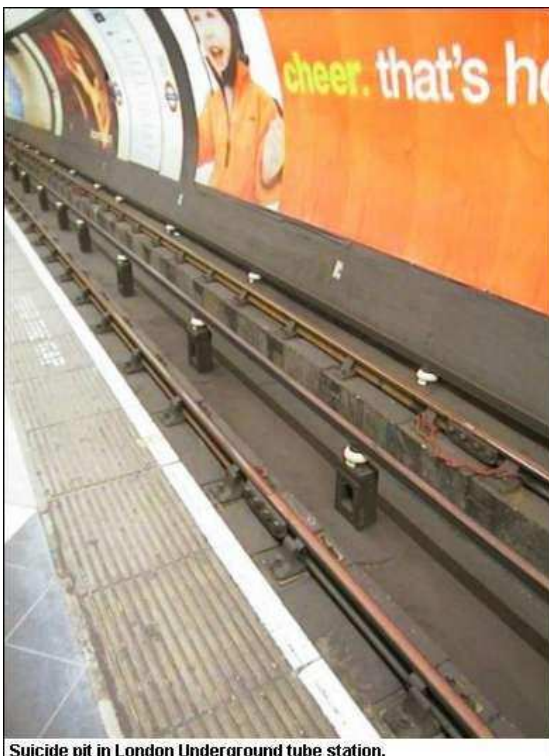

1.9. SUICIDE PITS

A feature of London's underground tube lines is that stations are provided with suicide pits. In London, there were so many suicides during the early 1930s, that all the deep level tube line stations were fitted with pits between the rails to facilitate removal of the bodies or rescue of the survivors. In recent times, there have been between 100 and 150 suicides on the system each year. This is two or three a week. For some strange reason, the Jubilee Line extension also has suicide pits even

though the stations are equipped with platform edge doors.

ROLLING STOCK AND EQUIPMENTS

2.1. AUXILIARY SYSTEMS ON ROLLING STOCK

2.1.1. Introduction

This page describes the on-board, compressed air auxiliary services required by trains and how they are provided on the locomotive and passenger vehicles

2.1.2. On-Board Services

The modern passenger train provides a number of on-board services, both for passengers and control systems. They are almost all electrically powered, although some require compressed air and a few designs use hydraulic fluid. Since a train is virtually a self contained unit, all the services are powered and used on board. Their use and features can be summarised as follows:

- a- Compressed air** almost always used for brakes and sometimes for powering automatic doors. Also once popular for powering traction power switches or contactors. Usually used for raising pantographs on overhead line systems. Always needs drying after compression to avoid moisture from condensation getting into valves. The compressor is normally driven directly from the main power source (the overhead line or third rail on electrified lines or the main generator on diesel powered vehicles).
- b- Battery** Normally provided on locomotives and trains as a basic, low voltage standby current supply source and for start up purposes when livening up a dead vehicle. The battery is normally charged from the on-board auxiliary power supply.
- c- Generator** the traditional source on a train for on-board, low voltage supplies. The generator is a DC machine driven by the diesel engine or, on electric locomotives, by a motor powered from the traction current supply. On a coach, the generator was often driven directly off an axle (a dynamo), a large bank of batteries providing power for lighting when the train was stationary.
- d- Alternator** the replacement for the generator which provides AC voltages instead of DC for auxiliary supplies. AC is better than DC because it is easier to transmit throughout a train, needing smaller cables and suffering reduced losses. Needs a rectifier to convert the AC for the battery charging and any other DC circuits.

e- Converter the replacement for the alternator. This is a solid state version of the alternator for auxiliary current supplies and can be a rectifier to convert AC to DC or an inverter to convert DC to AC. Both are used according to local requirements and some designs employ both on the same train. The name converter has become generic to cover both types of current conversion.

2.1.3. Air Equipment

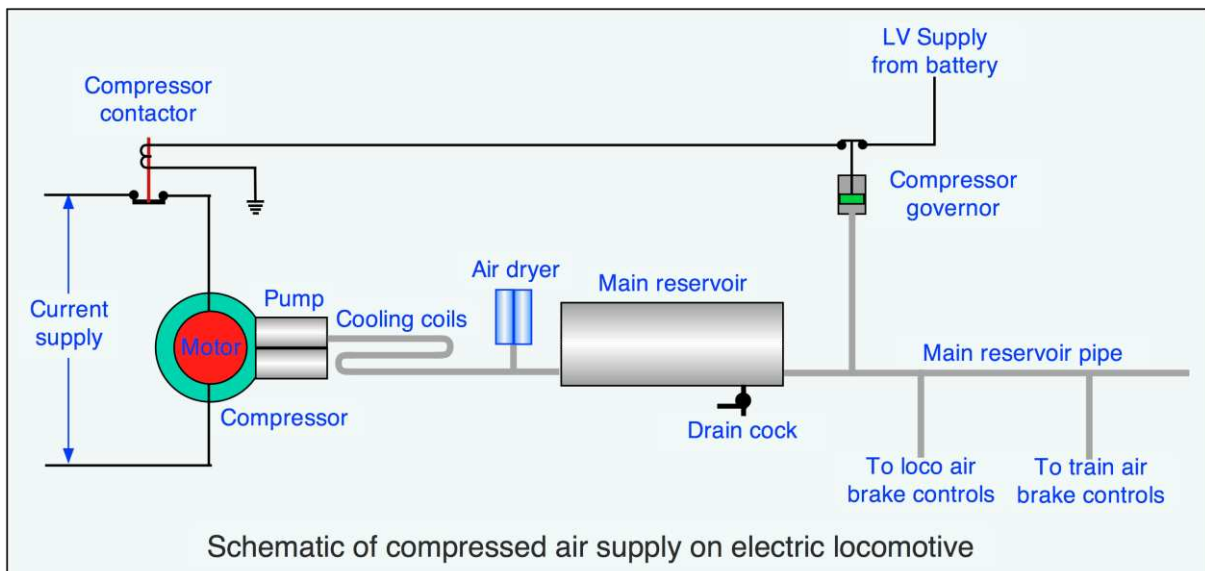

Looking at compressed air supplies first, the diagram left shows a typical arrangement for compressed air supply on a locomotive. The main items of equipment are a compressor, cooling pipes, an air dryer, a storage reservoir and controls.

2.1.4. The Compressor

The compressor itself consists of a pump driven by an electric motor. Power from the motor comes from the on-board electrical supply or, sometimes, directly from the traction supply. On electric locomotives, the supply can come from the transformer, via a rectifier and on a diesel locomotive, from the auxiliary alternator. On some diesel locomotives, the compressor is driven directly from the diesel engine by way of a connecting shaft.

2.1.5 The Pump

The traditional compressor pump was a piston in a cylinder. Later, two or three pistons were provided to increase compression speeds and give greater capacity. Some compressor manufacturers offer rotary pumps, which are generally much faster and considerably quieter than reciprocating pumps. They are however, usually more susceptible to mechanical faults and have lower capacity than reciprocating pumps. Development of quiet, reliable compressors continues.

2.1.6. Drives

Most compressors are directly coupled to their power source usually the electric motor. Some are belt driven, another attempt to get quieter operation. Belt drives were particularly common on the continent of Europe. As mentioned above, some diesel locomotives drive the compressor pump directly through a mechanical link with the diesel engine, so there is no separate electric motor.

2.1.7. Cooling

Compressing air makes it hot, so at least one set of cooling pipes will be provided. Some compressors have two sets. The pumping is split into two stages and a set of cooling pipes is provided between each, an inter-cooler and an after-cooler. Of course, the cooling produces condensation, which collects as water in the air pipes and, combined with oil from the compressor lubrication, forms a sludge which can quickly clog up sensitive brake valves. To overcome this problem, air systems are nowadays always provided with air dryers.

2.1.8. Drying

The air dryer consists of a pair of cylinders containing desiccant, which extracts the water and allows dry air to pass into the main reservoir. Water collected is automatically dumped once in each pumping cycle - the noise of the burst of water being discharged can often be heard at the end of the compressor's pumping cycle.

2.1.9. Control

The compressor is controlled automatically by a "compressor governor". The governor is designed to detect the point at which the compressed air level in the system has fallen to the lowest permitted level. As this happens, the governor switch contacts close and send a low voltage (LV) current to a "compressor contactor". The contactor is energised and closes a switch in the power supply to start the compressor motor. When the pressure reaches the required upper limit, the governor opens and the contactor switches out the compressor motor. All compressors also have an ON/OFF switch in the cab and there is usually a way of by-passing the governor in case something goes wrong with it.

2.1.10. Synchronisation

On a multiple unit train and when locomotives are coupled to operate in multiple, the compressor operation is usually synchronised. This means that if one compressor governor detects low air pressure, all compressors will switch on together throughout the train. When the last governor detects the air pressure is restored to its proper level, all compressors switch off together.

2.1.11. Storage

Each compressor set-up will have its own storage reservoir, normally called the main reservoir. This is a pressure-tested vessel, capable of storing enough air for multiple operations of all the equipment on the locomotive plus the train brakes. If there is more than one compressor, there will be more main reservoirs. Most modern locomotives have several and a multiple unit train will often have one on each car, whether there is a compressor on the car or not. Individual items of pneumatic equipment will also have their own storage reservoirs. It is not a good idea to run out of air, particularly for brakes! In New York City, this was carried to extremes, where some trains had a compressor on every car of an 11-car train.

2.1.12. Distribution

Once compressed, the air has to be distributed around the locomotive and along the train. Normally, for a freight train, the air is only needed for control of the braking system and a "brake pipe" is run the length of the train to achieve this. For locomotive hauled passenger trains too, a brake pipe is normally sufficient but for multiple unit trains, a compressed air supply is usually provided on every car.

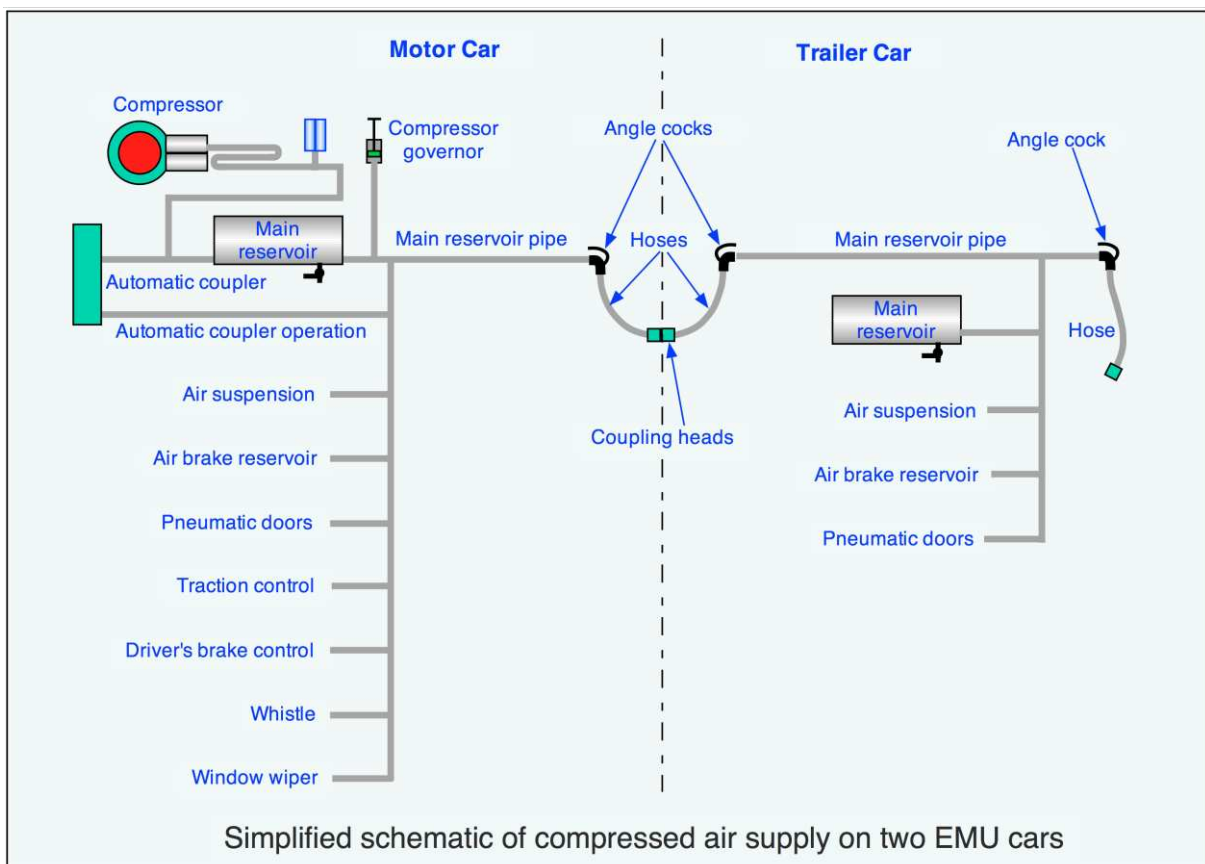

Compressed air distribution along a multiple unit train is by way of a "main reservoir pipe" (MR pipe), sometimes called a "main line pipe". The pipe is usually connected between cars by hoses. Each vehicle carries half the hose and is connected to the next car's hose by a cast steel coupling head which is designed to fit its opposite number. The heads will automatically disengage if they are forced apart by the sudden uncoupling of the train. They do this because, when the hoses become horizontal as the cars part, the heads reach a position where they uncouple.

Most of the standard equipment is listed in the drawing above but most EMU trains use air pressure to raise the pantograph (if fitted) and some third rail trains use air pressure for control of shoe contact with the current rail.

2.1.13. Angle Cocks

Most EMU vehicles have a MR pipe "angle cock" at each end. The angle cock can be closed to shut off the air supply at that point. Before uncoupling a vehicle, it is normal to close the angle cock on either side of the uncoupling position. This prevents any kick from the pipe as it is disengaged. Closing the angle cocks also has the effect of bleeding off the air trapped in the hose. The angle cock has a special bleed hole for this purpose.

2.1.14. Automatic Couplers

Many EMU's are provided with automatic couplers, usually at the ends of the unit. The coupler provides for all electrical, mechanical and pneumatic connections and is usually remotely operated from the driver's cab, or at least, inside the car. In the case of the MR pipe connection, a valve will open to provide the connection to the next unit once the cars are confirmed as coupled.

Sometimes, automatic couplers are operated by a compressed air supply. This is used to provide power to engage and disengage the mechanical coupling and to open and close the connecting valves and contacts.

2.1.15. Air Operated Equipment

Apart from automatic couplers and brakes, already mentioned above, there are a number of items on a train which can use compressed air for operation, although the modern trend is away from air in favour of electric systems. There are some simple items like the horn and the windscreen wiper and some more complex ones like traction control and door operation. Each item will have its own isolating cock to allow for maintenance and most of the larger systems have their own storage reservoir.

Many systems do not need the full main reservoir air pressure of 6 to 7 bar (120 to 140 lbs./in²), so they are equipped with reducing valves on the upstream side of the reservoir. Some are equipped with gauges as well, although most engineers prefer just a

test plug. Gauges stick out and get knocked off too easily. Nothing drains a reservoir more quickly than a broken gauge.

2.1.16. Traction Equipment

Although electrical operation of traction control equipment is the most common, some traction control systems use compressed air to operate circuit breakers, contractors or camshafts. There is normally a traction control reservoir and its associated isolating cock provided for each vehicle set of equipment.

2.1.17. Doors

Many rapid transit and suburban trains still use air operated door systems, controlled from the cab at one end of the train but using air stored in reservoirs on each car. The reservoirs are replenished automatically by way of their connection to the main reservoir pipe. Door systems usually use lower than normal MR air pressure. However, electric operators are the preferred option these days.

2.1.18. Air Suspension

Placing the car body on air pressure springs instead of the traditional steel springs has become common over the last 20 years for passenger vehicles. The air spring gives a better ride and the pressure can be adjusted automatically to compensate for additions or reductions in passenger loads. The changes in air pressure are used to give the brake and acceleration equipment the data needed to allow a constant rate according to the load on the vehicle.

2.1.19. Driver's Brake Control

Most trains use compressed air for brake operation. Most locomotives and older EMU's use a pneumatic brake control system which requires a brake valve to be operated by the driver. The valve controls the flow of air into and out of the brake pipe which, in turn, controls the brakes on each vehicle in the train consist. The driver's brake valve is connected to the MR pipe in the cab so that there is always a constant supply of air available to replenish the brake control system when required. An isolating cock is provided in the cab so that the brake control can be closed off when the cab is not in use.

2.1.20. Pantograph Compressor

One additional compressor is often provided on units which have air operated pantographs, i.e. those which are raised or lowered using compressed air as the power medium. Opening up a completely dead locomotive is only possible if there is battery power and some compressed air available to get the pantograph up to the overhead power supply. After all, nothing will work on the loco without power. So, a small, battery powered compressor is provided to give sufficient compressed air to raise the

pantograph. As soon as the pan is up, full power is available to operate the main compressor.

2.2. ELECTRICAL AUXILIARY EQUIPMENT

2.2.1. Introduction

This page describes the on-board electrical services required by electric trains and how they are provided on the locomotive and passenger vehicles.

2.2.2. On-Board Services

The modern passenger train provides a number of on-board services, both for passengers and control systems. They are almost all electrically powered, although some require compressed air and a few designs use hydraulic fluid. Since the train is virtually a self contained unit, all the services are powered and used on board. Their use and features can be summarised as follows:

- a- Compressed air** almost always used for brakes and sometimes for powering automatic doors. Also once popular for powering traction power switches or contactors. Usually used for raising pantographs on overhead line systems. Always needs drying after compression to avoid moisture getting into valves. The compressor is normally driven directly from the main power source (the overhead line or third rail on electrified lines or the main generator on diesel powered vehicles).
- b- Battery** Normally provided on locomotives and trains as a basic, low voltage standby current supply source and for start up purposes when livening up a dead vehicle. The battery is normally permanently charged from an on-board power supply.
- c- Generator** the traditional source for on-board low voltage supplies. The generator is a DC machine driven by the diesel engine or, on electric locomotives, by a motor powered from the traction current supply. On a coach, the generator was often driven directly off an axle (a dynamo), batteries providing power for lighting when the train was stationary.
- d- Alternator** the replacement for the generator which provides AC voltages for auxiliary supplies. AC is better than DC because it is easier to transmit throughout a train, needing smaller cables, and suffering reduced losses. Needs a rectifier to convert the AC for the battery charging and any other DC circuits.
- e- Converter** the replacement for the alternator. This is a solid state version for auxiliary current supplies and can be a rectifier to convert AC to DC or an inverter to convert DC to AC. Both are used according to local requirements and some designs employ both on the same train. The name converter has become generic to cover both types of current conversion.

2.2.3. High Voltage and Low Voltage Systems

A locomotive or multiple unit is provided with two electrical systems, high voltage (HV) and low voltage (LV). The high voltage system provides power for traction and for the low voltage system. The low voltage system supplies all the auxiliary systems on the train like lighting, air conditioning, battery charging and control circuits. The two are separated because the high voltage required for traction is not needed for most of the other systems on the train so it is wasteful and expensive to use the high voltage.

2.2.4. Converting HV to LV

The current drawn by a locomotive from the overhead line or third rail supply can be supplied at voltages ranging from 25,000 volts AC to 600 volts DC. With the exception of heaters and compressor motors which, on the lower voltage DC railways are normally powered by the line current, all of these supply voltages are really too high to use efficiently with the comparatively small loads required by the on-board services on a train. The common approach therefore, has been to reduce the line voltage to a suitable level - generally below 450 volts and on some systems as low as 37.5 volts. Most systems have used a dynamo, a generator, an alternator or a current converter to get the lower voltages required. Usually, different voltages are used for different applications, the particular conversion system being specially designed to suit.

2.2.5. Development

The first electric lighting provided on steam hauled trains was supplied from a large capacity battery contained in a box slung under the coach. The battery was recharged by a dynamo powered by a belt driven off one of the coach axles. Of course, this meant that the battery was recharged only when the train was moving and it had to have sufficient capacity for prolonged station stops, particularly at terminals. The voltage varied from system to system but was usually in the 12 to 48 volt range. Trains were heated by steam piped from the engine. If the locomotive was electric or diesel, a train heating boiler would be installed on the locomotive. Some European railways had train equipped with both steam and electric heating. More recently, all heating has become electric.

Electric trains originally used power obtained directly from the line for lighting and heating. The lamp voltage was kept to a low level by wiring groups of lamps in series. Each vehicle had its own switch which had to be operated by a member of the crew. On some railways, where there were tunnels, daytime crews were instructed to switch on all the lights at the station before the tunnel and switch them off at the station after the exit. Such stations were provided with staff allocated to this job.

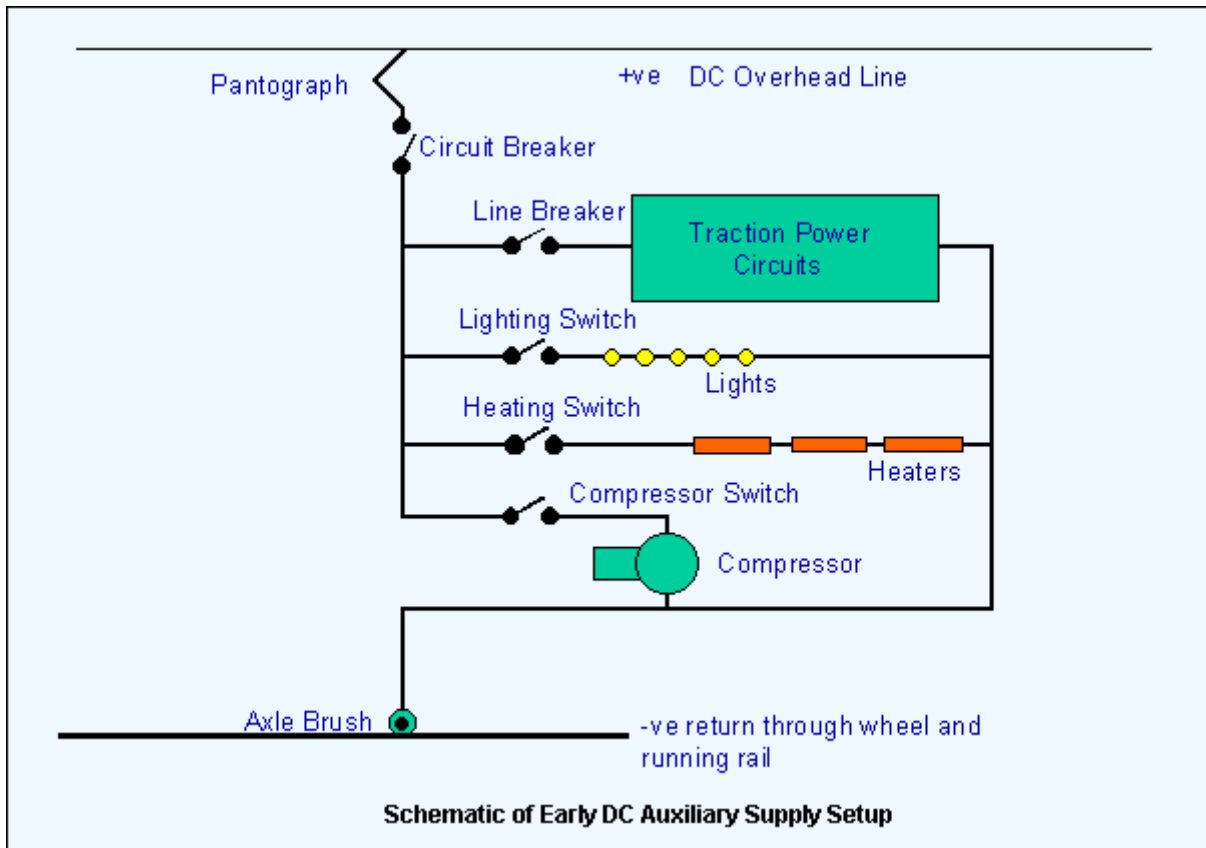

This diagram shows the basics for an early electric train set-up with a DC overhead line power supply system. The line voltage supplies the lighting, heating and compressor power requirements directly. The only reduction in voltage is achieved by wiring lamps and heaters in series. Each circuit has its own switch. The compressor would also have a [governor](#), not shown here. This diagram shows a typical arrangement before about 1914. After that time, trains were equipped with [multiple unit control](#) of auxiliary services, where all cars were controlled from one position using separate control wires running along the train. Multiple unit control of traction equipment arrived in the UK from the US in 1903.

Batteries were still provided on some electric trains, especially those on underground lines, for emergency lighting. A small number of lamps in each car were connected to the battery so that some illumination was available if the main traction current supply was lost. The batteries were recharged through a resistance fed from the traction current supply.

2.2.6. Motor Generators

In the mid 1930s, electric multiple units began appearing with on-board, DC generators to supply lights. This allowed lower voltages and reduced the heavy wiring required for traction current fed lighting. Outputs from these generators ranged from 37 to 70 volts, depending on the application. The generator was driven by a small electric motor

powered by the traction supply. For this reason they were often referred to as "motor generators".

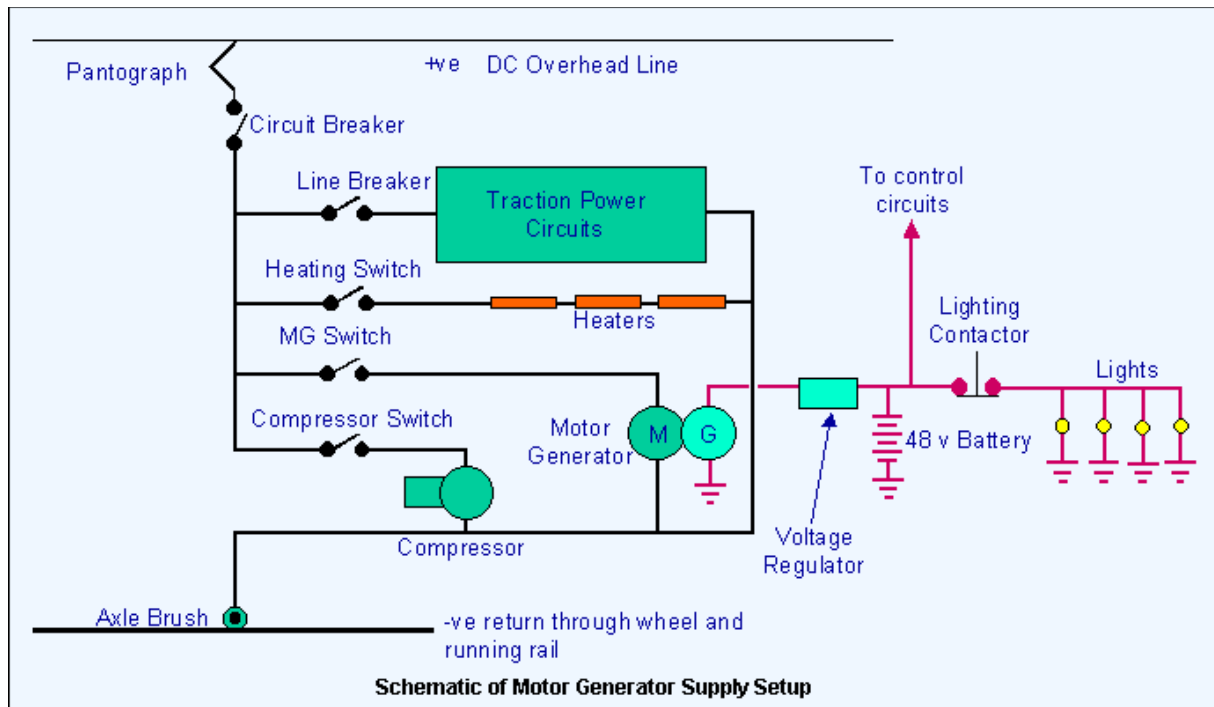

In this diagram of a motor generator system, the train lighting and battery are fed from a generator driven by a motor at the line voltage. The return circuit is through ground, using the car structure like a road vehicle. A voltage regulator is provided to reduce the risk of damage through sudden changes in voltage caused by gaps in the current rail or neutral sections in the overhead line. If the MG stops, the battery is disconnected from the charging circuit and supplies a few emergency lights. In addition to supplying lighting, the LV circuit was used to supply all the train's control circuits

2.2.7. Motor Alternators

By the late 1940s, fluorescent lighting was becoming popular and was recognised as better, brighter and requiring less current than tungsten bulbs. However, if DC is used, the lighting tubes become blackened at one end, so AC was adopted for lighting circuits on trains. At first, some systems used a DC generator with an alternator added to the drive shaft, a motor-generator-alternator. The DC output from the generator was used for control circuits while the AC output from the alternator was used for lighting. Emergency lighting was still tungsten, fed from the battery.

In the early 1960s, the motor alternator appeared. The appearance of silicon rectifiers allowed the AC output of the alternator to be converted to DC for battery charging and control circuits. The introduction of solid state electronics also saw the old mechanical voltage regulators replaced.

2.2.8. Electronic Auxiliaries

Modern auxiliary services on electrified railways are now mostly solid state systems, using power and control electronics, as shown in the diagram below:

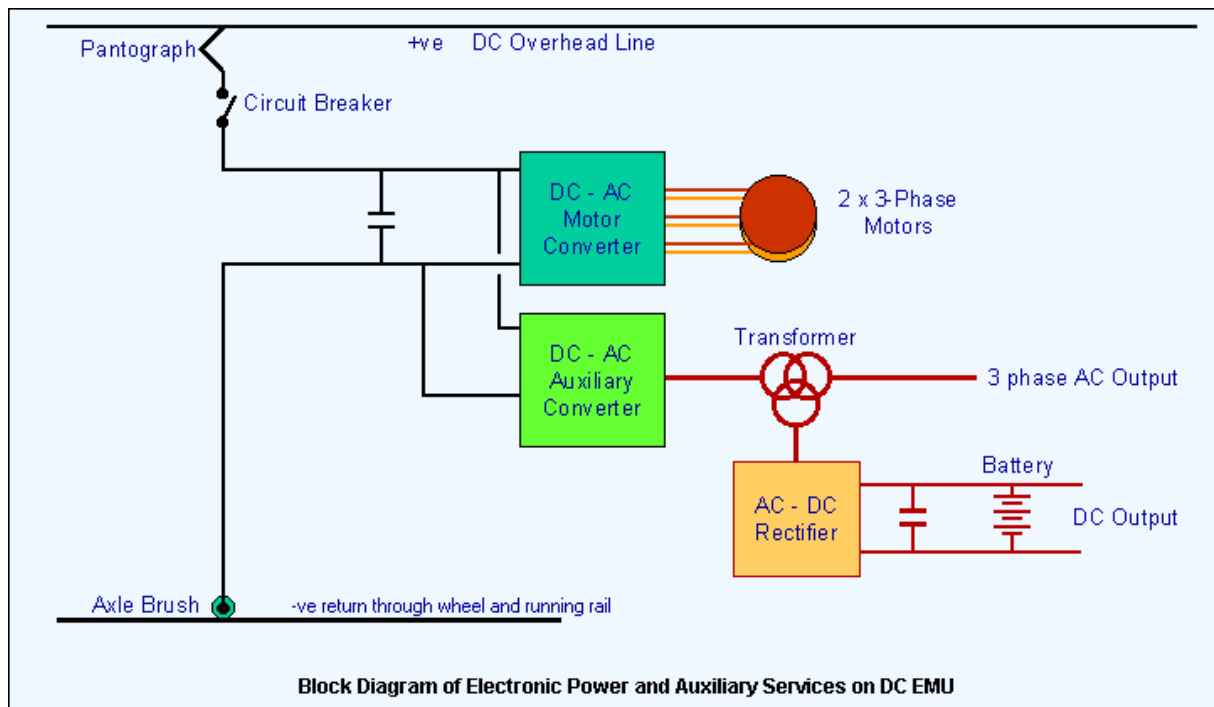

The output from the DC to AC auxiliary converter is 3-phase AC at about 380 volts and is used for train lighting and the AC motors of air conditioning fans and compressors. The 3-phase is also converted to DC by the rectifier which provides current for battery charging and control circuits. The diagram on the left shows the set-up for a DC overhead system but it is similar for AC systems except for the addition of the transformer and rectifier as shown below.

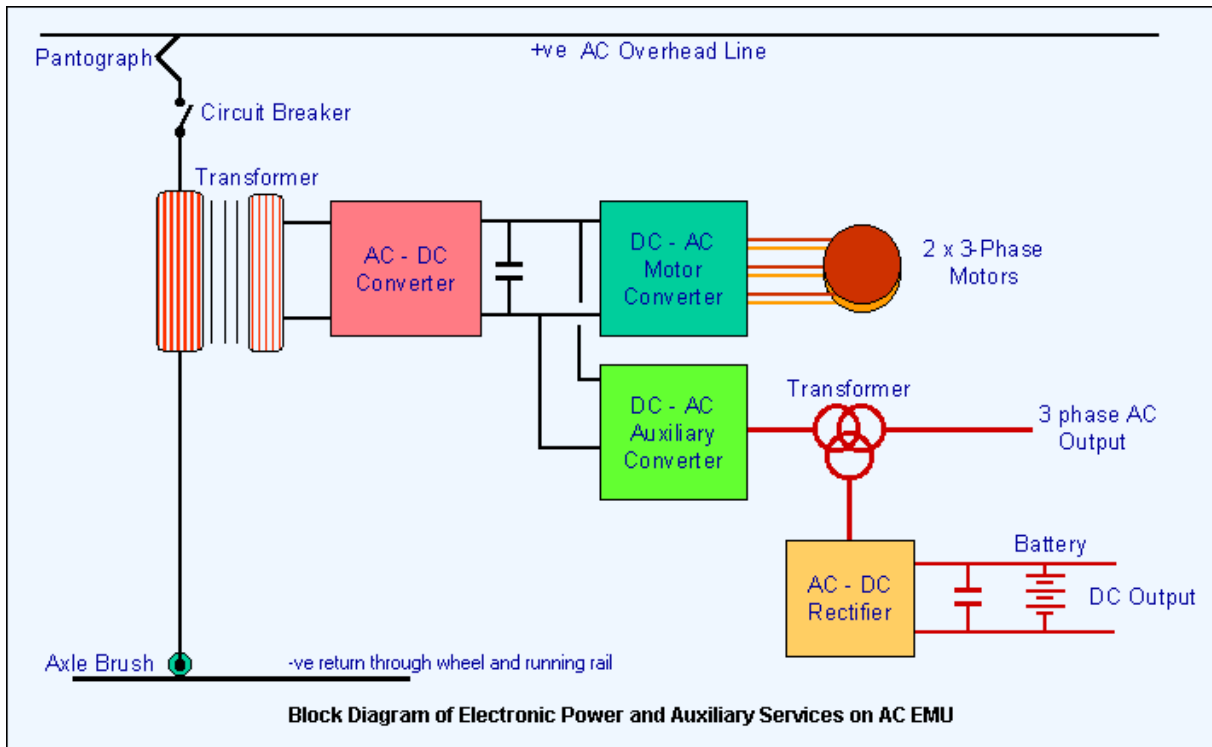

On a locomotive hauled train, the individual coaches are provided with an on-board converter supplied from a train line carrying a 3-phase supply generated on the locomotive. On a diesel locomotive, this supply would come from an on-board alternator driven by the diesel engine.

2.2.9. Gaps

A feature of electric railway operation is the gap or neutral section. Gaps occur in third rail systems and neutral sections in overhead line systems. See also [Electric Traction Pages Power Supplies](#). The gap in a current rail is necessary at junctions to allow the continuity of the wheel/rail contact and at substations to allow the line to be divided into separate sections for current feeding purposes. Neutral sections in the overhead line are also used for this purpose.

Although they are always kept as short as possible, gaps will sometimes cause loss of current to the train. The train will usually coast over the gap but there will be a momentary loss of current to the on-board equipment lights will go off for a second or two and ventilation fans will slow down or stop. On trains provided with generators or alternators, the momentum in the machine would often be sufficient to maintain some generation over the gap and lighting often remained unaffected. The only difference noticeable to the passenger was the change in the sound of the generator as it lost power and then regained it a second or two later.

Modern electronics has given us static inverters to supply on-board inverters but they have no inertia and stop output as soon as a gap is encountered. To prevent the lights going off at every little gap, all lights are connected through the battery. To prevent the battery becoming discharged too quickly, the inverter starts a "load shed" at about a 60 second delay. After this time, the main lighting is switched out and only emergency lights remain. Battery current is also used for emergency ventilation, essential controls and communications.

2.3. BOGIE PARTS & DESCRIPTION

2.3.1. Introduction

The bogie, or truck as it is called in the US, comes in many shapes and sizes but it is in its most developed form as the motor bogie of an electric or diesel locomotive or an EMU. Here it has to carry the motors, brakes and suspension systems all within a tight envelope. It is subjected to severe stresses and shocks and may have to run at over 300 km/h in a high speed application. The following paragraphs describe the parts shown on the photograph below, which is of a modern UK design.

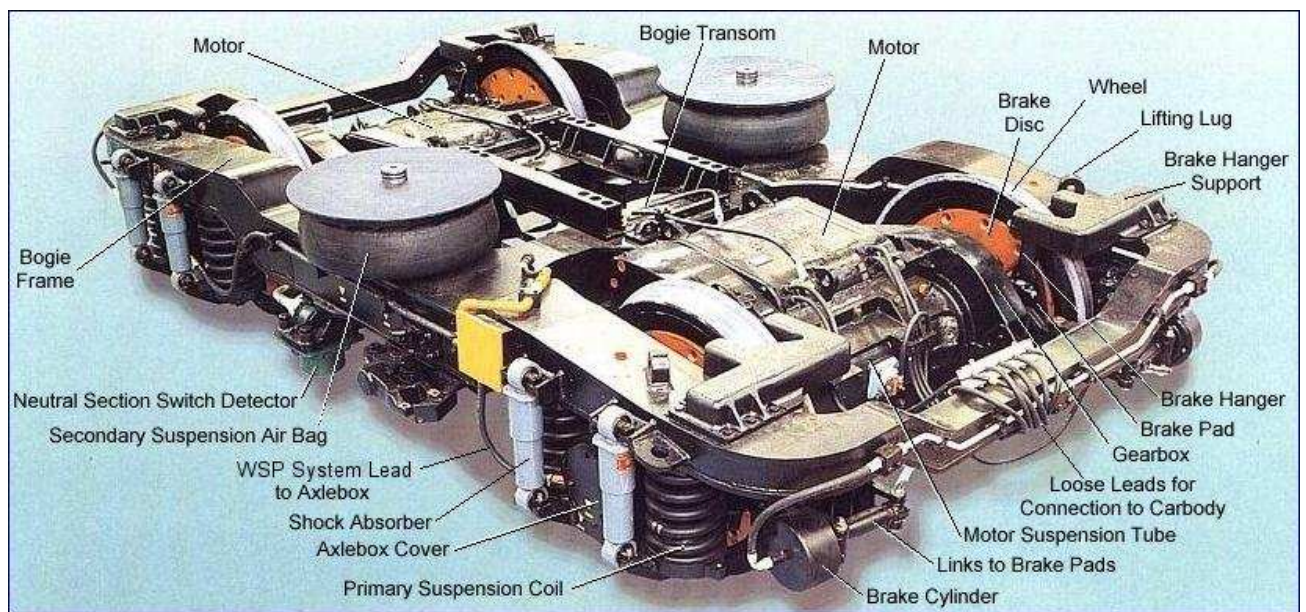

Bogie Frame

Can be of steel plate or cast steel. In this case, it is a modern design of welded steel box format where the structure is formed into hollow sections of the required shape.

Bogie Transom

Transverse structural member of bogie frame (usually two off) which also supports the carbody guidance parts and the traction motors.

Brake Cylinder

An air brake cylinder is provided for each wheel. A cylinder can operate tread or disc brakes. Some designs incorporate parking brakes as well. Some bogies have two brake cylinders per wheel for heavy duty braking requirements. Each wheel is provided with a brake disc on each side and a brake pad actuated by the brake cylinder. A pair of pads is

hung from the bogie frame and activated by links attached to the piston in the brake cylinder. When air is admitted into the brake cylinder, the internal piston moves these links and causes the brake pads to press against the discs. A brake hanger support bracket carries the brake hangers, from which the pads are hung.

Primary Suspension Coil

A steel coil spring, two of which are fitted to each axlebox in this design. They carry the weight of the bogie frame and anything attached to it.

Motor Suspension Tube

Many motors are suspended between the transverse member of the bogie frame called the transom and the axle. This motor is called "nose suspended" because it is hung between the suspension tube and a single mounting on the bogie transom called the nose.

Gearbox

This contains the pinion and gearwheel which connects the drive from the armature to the axle.

Lifting Lug

Allows the bogie to be lifted by a crane without the need to tie chains or ropes around the frame.

Motor

Normally, each axle has its own motor. It drives the axle through the gearbox. Some designs, particularly on tramcars, use a motor to drive two axles

Neutral Section Switch Detector

In the UK, the overhead line is divided into sections with short neutral sections separating them. It is necessary to switch off the current on the train while the neutral section is crossed. A [magnetic device](#) mounted on the track marks the start and finish of the neutral section. The device is detected by a box mounted on the leading bogie of the train to inform the equipment when to switch off and on.

Secondary Suspension Air Bag

Rubber air suspension bags are provided as the secondary suspension system for most modern trains. The air is supplied from the train's compressed air system.

Wheel Slide Protection System Lead to Axlebox

Where a Wheel Slide Protection (WSP) system is fitted, axleboxes are fitted with speed sensors. These are connected by means of a cable attached to the WSP box cover on the axle end.

Loose Leads for Connection to Carbody

The motor circuits are connected to the traction equipment in the car or locomotive by flexible leads shown here.

Shock Absorber

To reduce the effects of vibration occurring as a result of the wheel/rail interface.

Axlebox Cover

Simple protection for the return current brush, if fitted, and the axle bearing lubrication.

2.4. WHEELS AND BOGIES

2.4.1. Introduction

A short description of the principles of the wheel/rail interface.

2.4.2. The Wheel on the Rail

Railway wheels sit on the rails without guidance except for the shape of the tyre in relation to the rail head. Contrary to popular belief, the flanges should not touch the rails. Flanges are only a last resort to prevent the wheels becoming derailed a safety feature. The wheel tyre is coned and the rail head slightly curved as shown in the following diagram (Fig 1). The degree of coning is set by the railway company and it varies from place to place. In the UK the angle is set at 1 in 20 (1/20 or 0.05). In France it's at 1/40. The angle can wear to as little as 1 in 1.25 before the wheel is reprofiled.

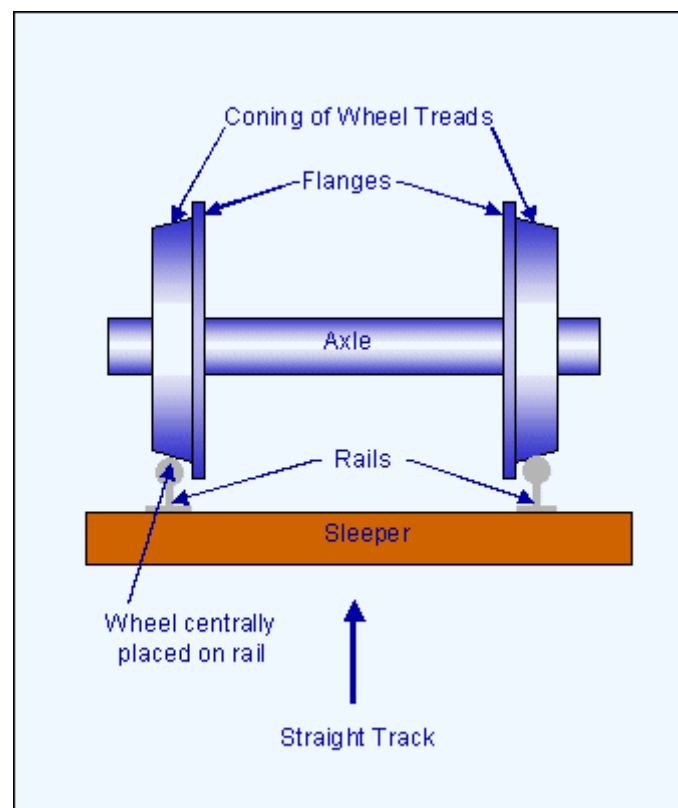

Fig 1: The shape and location of wheels and rails on straight track.

This diagram is exaggerated to show the principal of the wheel/rail interface on straight track. Note that the flanges do not normally touch the rails.

On curved track, the outer wheel has a greater distance to travel than the inner wheel. To compensate for this, the wheelset moves sideways in relation to the track so that the

larger tyre radius on the inner edge of the wheel is used on the outer rail of the curve, as shown in Fig 2.

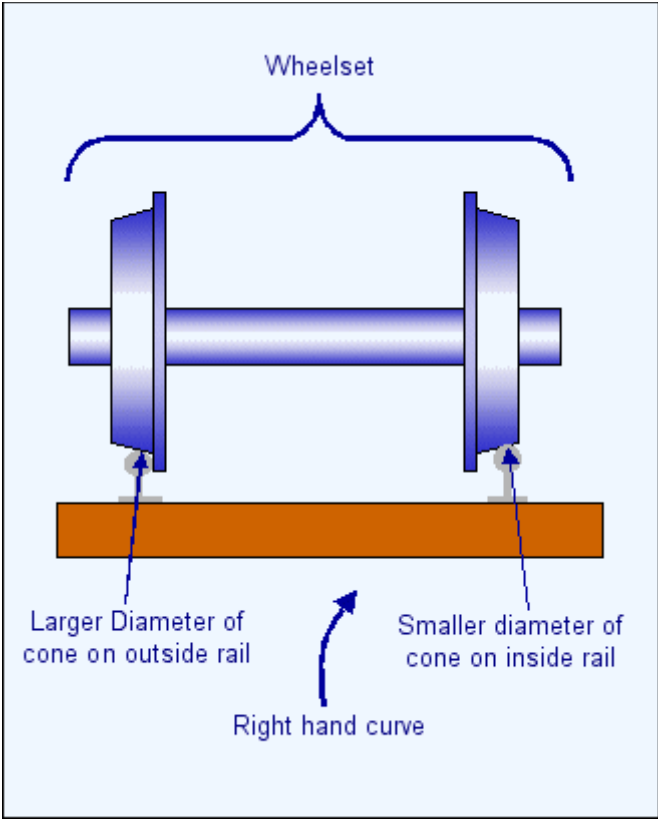

Fig 2: The location of the wheels in relation to the rails on curved track.

The inner wheel uses the outer edge of its tyre to reduce the travelled distance during the passage round the curve. The flange of the outer wheel will only touch the movement of the train round the curved rail is not in exact symmetry with the geometry of the track. This can occur due to incorrect speed or poor mechanical condition of the track or train. It often causes a squealing noise. It naturally causes wear.

Many operators use flange or rail greasing to ease the passage of wheels on curves. Devices can be mounted on the track or the train. It is important to ensure that the amount of lubricant applied is exactly right. Too much will cause the tyre to become contaminated and will lead to skidding and flatted wheels.

There will always be some slippage between the wheel and rail on curves but this will be minimised if the track and wheel are both constructed and maintained to the correct standards.

2.4.3. Bogies (Trucks)

A pair of train wheels is rigidly fixed to an axle to form a wheelset. Normally, two wheelsets are mounted in a bogie, or truck as it is called in US English. Most bogies have rigid frames as shown below (Fig 3).

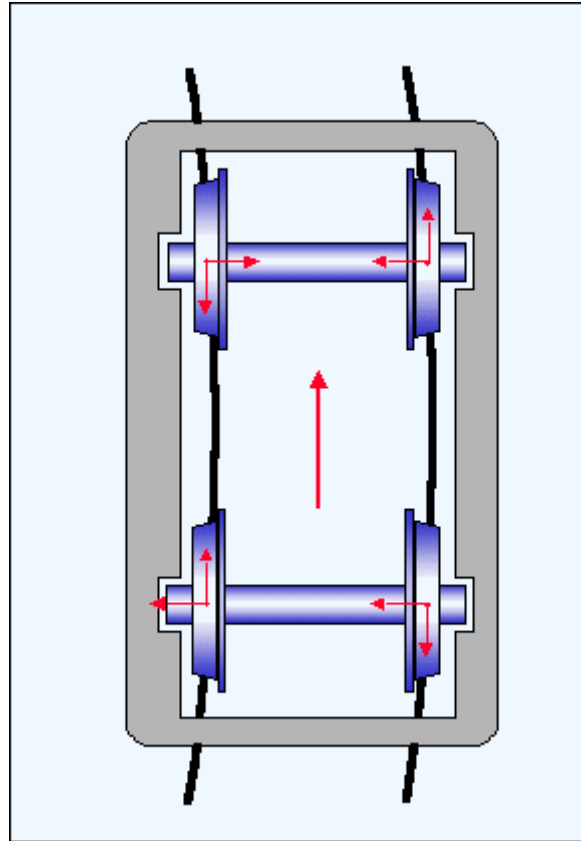

Fig 3: A standard rigid bogie on curved track.

The bogie frame is turned into the curve by the leading wheelset as it is guided by the rails. However, there is a degree of slip and a lot of force required to allow the change of direction. The bogie is, after all, carrying about half the weight of the vehicle it supports. It is also guiding the vehicle, sometimes at high speed, into a curve against its natural tendency to travel in a straight line.

2.4.4. Steerable Bogies

To overcome some of the mechanical problems of the rigid wheelset mounted in a rigid bogie frame, some modern designs incorporate a form of radial movement in the wheelset as shown below (Fig 4)

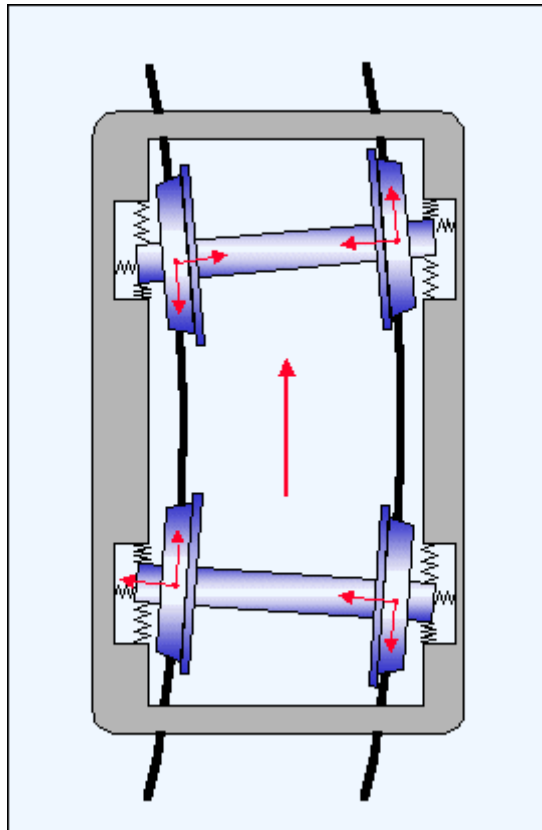

Fig 4: A bogie on curved track with radially steering wheelsets.

In this example, the wheelset "floats" within the rigid bogie frame. The forces wearing the tyres and flanges are reduced as are the stresses on the bogie frame itself. There are some designs where the bogie frame is not rigid and the steering is through mechanical links between the leading and trailing wheelset.

2.5. VEHICLE SUSPENSION SYSTEMS

2.5.1. Introduction

Almost all railway vehicles use bogies (trucks in US parlance) to carry and guide the body along the track. Bogie suspension design is a complex and difficult science which has evolved over many years. Some of the significant steps in progress are described here.

2.5.2. Development

It was recognised very early in the development of railways that the interface between vehicle body and wheel needed some sort of cushion system to reduce the vibration felt as the train moved along the line. This was already part of road coach design and took the form of leaf (laminated) steel springs mounted on the axles, upon which the vehicle body rested. Railways in the UK used the same principle, as shown here.

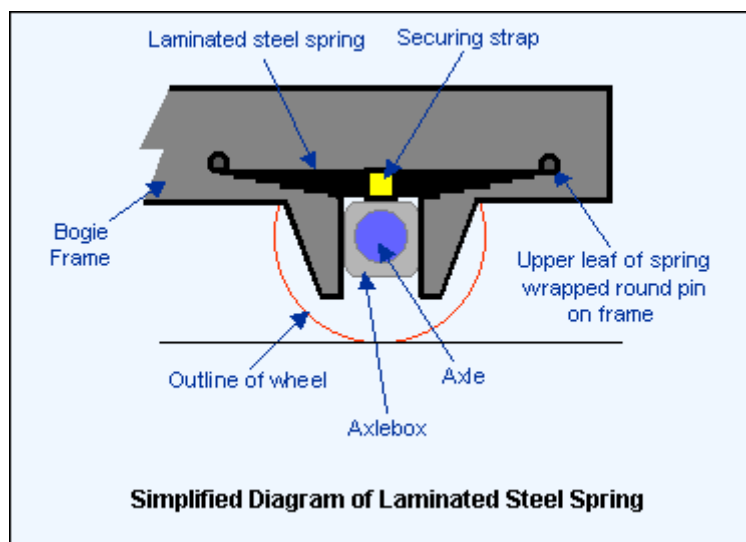

The spring consisted of a set of different length steel plates arranged with the longest at the top and the shortest at the base of the set. They were held together with a steel strap in the centre. This strap formed the point of contact with the axlebox. The laminations or "leaves" of steel gave rise to the "leaf spring" name more commonly used today. They were also referred to as "elliptical" springs, on account of the curved shape they often formed.

The top steel plate of the spring was secured to the vehicle underframe by having the ends wrapped round steel pins. The pins, two for each spring assembly, were fixed to the underframe. When mounted on the wheelset, the vehicle body weight was transmitted through the pins and the laminated steel spring to the axlebox.

The axlebox was only allowed vertical movement, since it was restrained by two "horns" extending down from the underframe. The horns had "horn guides" (not shown) to ensure security and to prevent twisting.

2.5.3. Plate Frame Bogie Primary Suspension

The natural progression from the rigid framed vehicles used in the early days of European railways to a bogie vehicle brought with it a more sophisticated suspension system. This system was based on a steel plate framed bogie with laminated spring axlebox suspension, much as seen on the first vehicles, and with a secondary suspension added between the car body and the bogie. First, we look at the primary suspension.

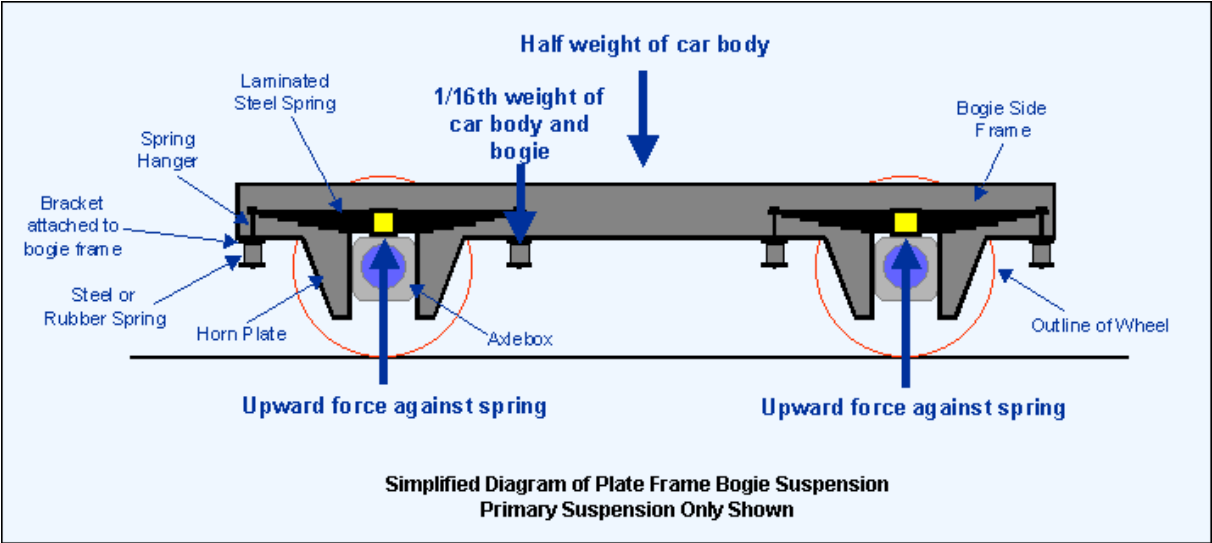

The diagram above shows a plate framed bogie with the primary, axlebox suspension. The secondary, bolster suspension is left out for simplicity. The bogie carries half the car weight which is then divided roughly equally between the two axles. If we said the whole vehicle weight was 30 tonnes, each bogie would carry 15 tonnes and each axle 7.5 tonnes. For a civil engineer wanting to know the stresses on his structures and track, we would tell him we had a 7.5 tonne axle load. Of course, we would include the carrying load of passengers and freight in this calculation.

Returning to the primary suspension design, we see that the laminated axlebox spring is fitted with two "spring hangers" attached to the outer ends of the longest spring plate. Each hanger passes through a hole in a bracket attached to the bogie frame and is screwed into another bracket at the bottom end. Between the two brackets is a steel or rubber spring. The weight of the bogie on the axlebox is transmitted through the steel laminated spring and the two spring hangers. Each spring hanger and its associated spring carries 1/16th of the total car weight. The height of the bogie relative to the rail

level could be adjusted by using the screwed spring hangers. The adjustment allowed for small variations in wheel diameter.

2.5.4. Plate Frame Bogie Secondary Suspension

The secondary suspension of the bogie is mounted crosswise (transversely) in the centre. End on, it looks as shown below:

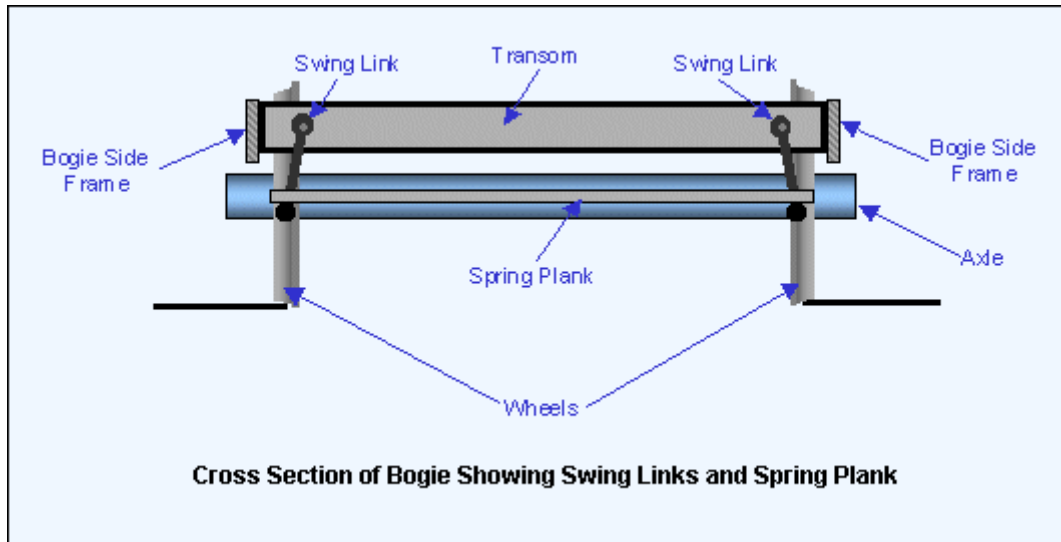

The bogie has a pair of transverse members called "transoms". They are rivetted or welded (depending on the design) to the bogie side frames. A steel "swing link" is hung from each end of each transom and a spring plank is laid across the bogie between them. A side view of the bogie below shows the way the spring plank is supported by the swing links.

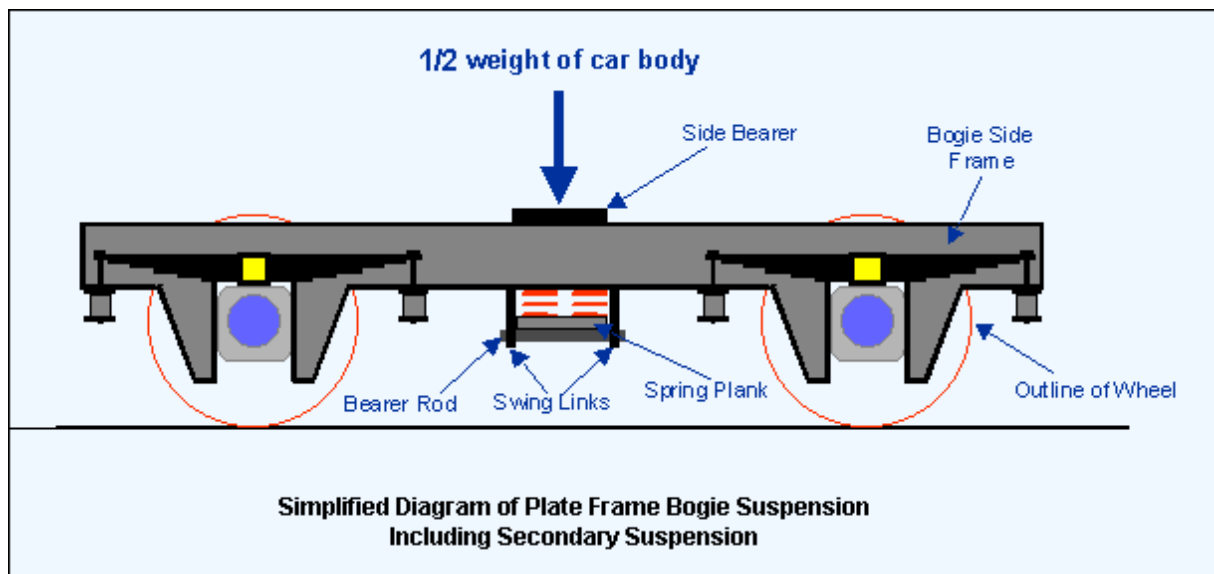

The spring plank rests on bearer rods suspended between the swing links. This arrangement allows the spring plank to rock from side to side and it will act in opposition

to sideways movement of the bogie frame. The spring plank, as its name suggests, carries springs, as shown in the next diagram.

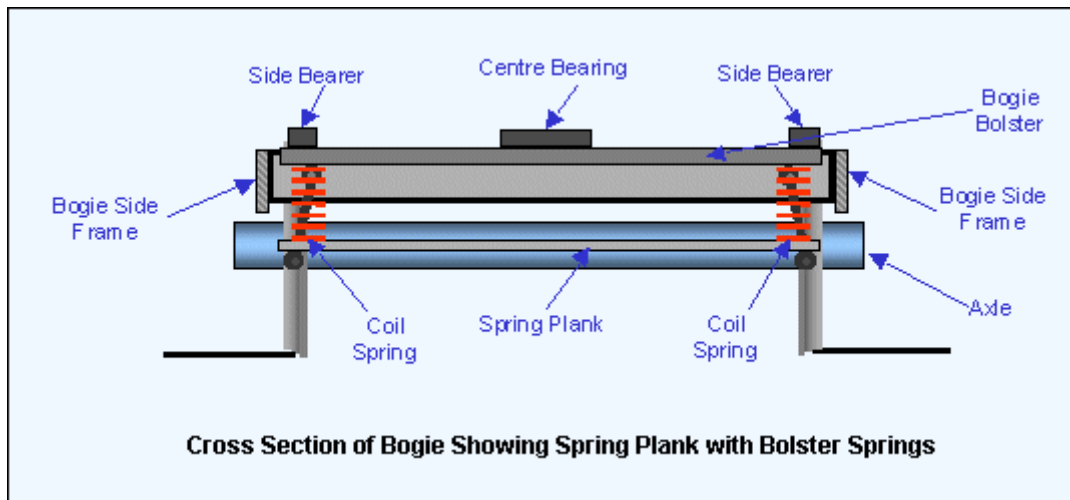

A pair of steel coil springs (shown in red) rest on each end of the spring plank. On top of them sits the bogie bolster. The bolster carries the vehicle body. The body is located by a centre bearing, using a pin fitted to the underframe of the body and steadied by two side bearers. The side bearers are flat to allow the body to slide on the bearer so that the bogie can turn about the centre pin.

This type of arrangement began to be replaced by more modern designs from the 1960s but it is still common around the world and there are many variations. Nevertheless, the basic principles of primary and secondary suspension on bogies are common throughout.

2.5.5. Cast Steel Bogies

In the US, cast steel was the most popular material for bogies and a simple basic design evolved as we can see in the diagram left.

In its simplest form, as used under the standard American freight car, sprung suspension was only provided for the bolster. The bogie consisted of three main parts the bolster and the two side frames. The basic arrangement provided for a set of steel coil springs provided inside an opening in each side frame of the bogie. The bogie bolster (truck bolster in the US) was mounted on top of these springs and held in place by guides cast into or bolted onto the bolster. The axleboxes were not sprung and merely slotted into the frame, which rested directly on them. The ride wasn't soft but it was adequate. Some later versions of this truck have axlebox springs simple coil springs inserted between the top of the axlebox and the truck frame.

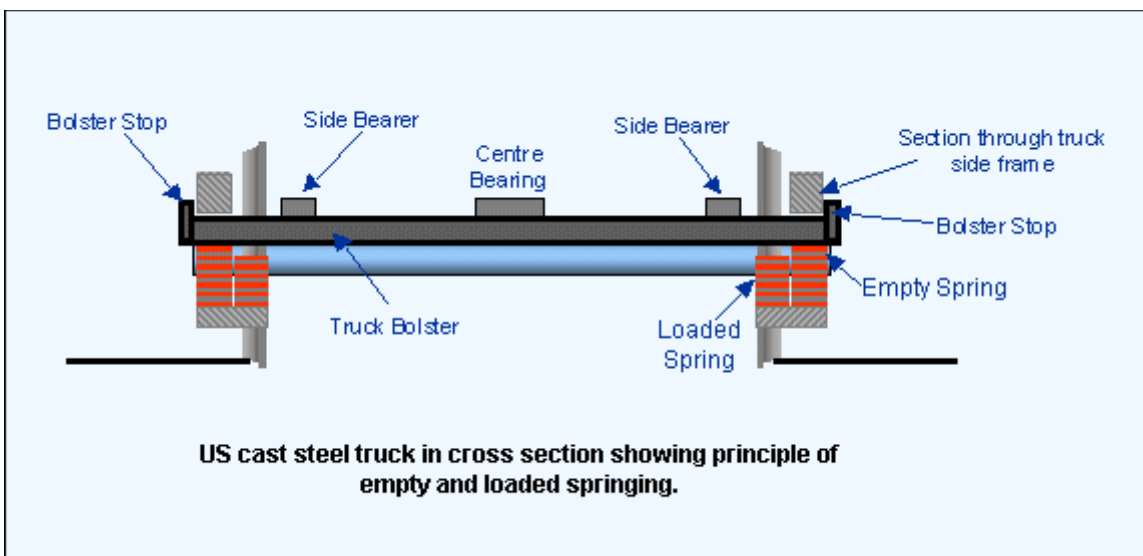
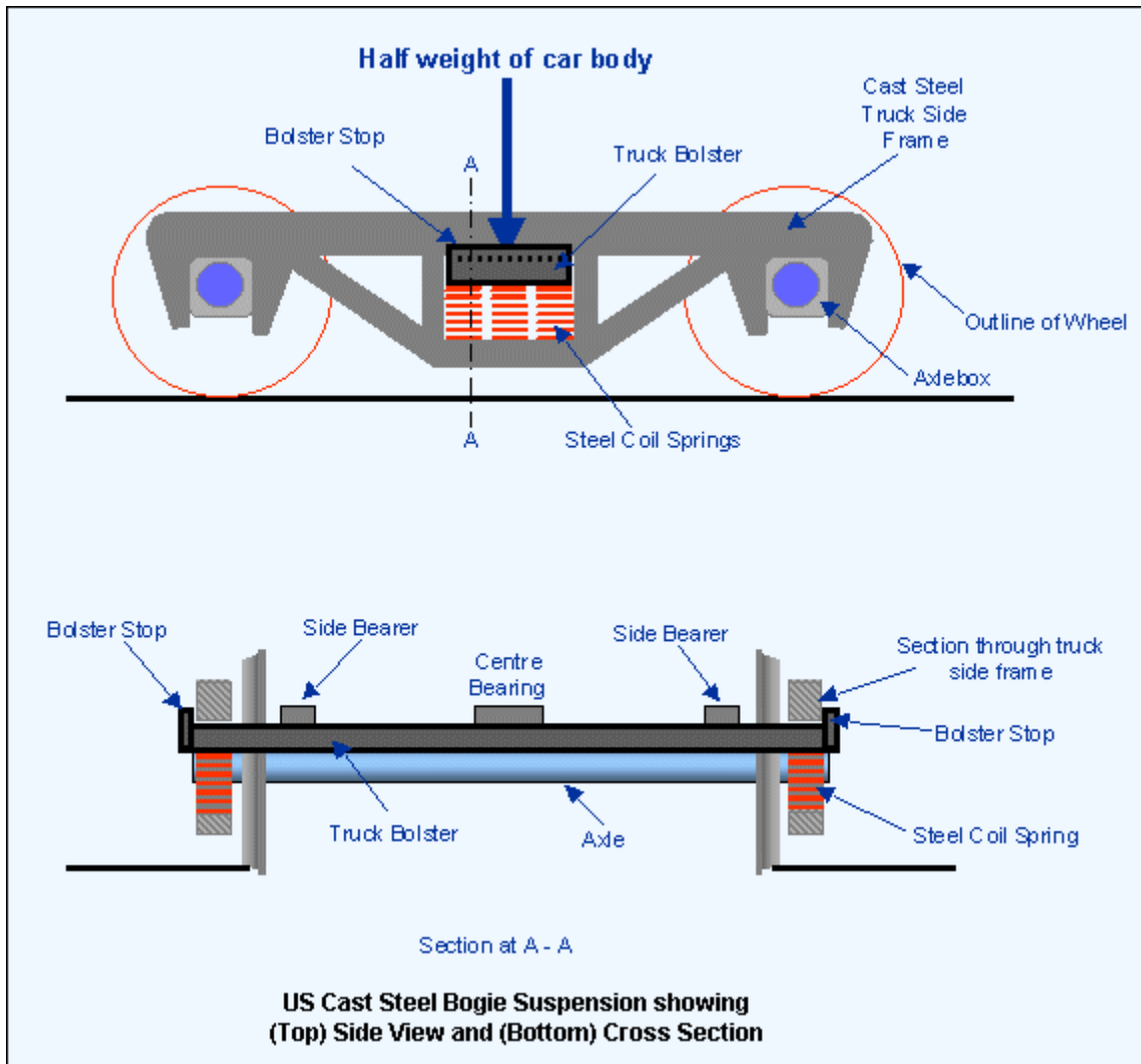

Of course, nothing is as simple as it looks at first sight. So it is with the US freight truck, which is actually a bit more complicated than seen above. If you bear in mind that a freight car can become five times heavier when it is loaded than when it is empty, it

becomes clear that the suspension must be stronger to carry the load. The US type has a second set of bolster springs as shown left.

The second set of springs only comes into contact with the truck bolster when it is depressed by the extra weight loaded on the vehicle. The loaded springs are stiffer than the empty springs so that the stability is maintained regardless of the load applied. These loaded springs are normally fitted with friction blocks (not shown for simplicity) on top to allow proper alignment and to regulate the reaction of the spring to the load.

Freight bogies in Europe and UK are also fitted with load compensation systems using double springs and friction damping devices but they are usually more complex than the simple US design.

2.5.6. Equaliser Bar Suspension

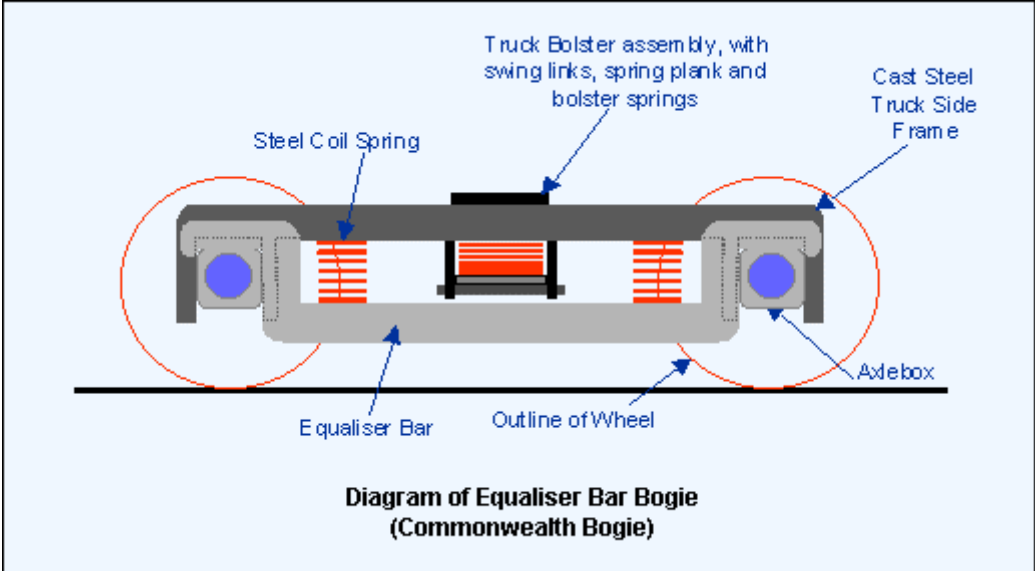

A design popular in the US was the equaliser bar truck, which we can see in the following simplified diagram. It was also known as the Commonwealth Bogie.

The side frame of the bogie was usually of bar construction, with simple horn guides attached, allowing the axleboxes vertical movements between them. The axleboxes had a cast steel equaliser beam or bar resting on them. The bar had two steel coil springs placed on it and the truck frame rested on the springs. The effect was to allow the bar to act as a compensating lever between the two axles and to use both springs to soften shocks from either axle. The truck had a conventional bolster suspension with swing links carrying a spring plank.

In a reversal of British practice, the equaliser bar truck had leaf springs supporting the bolster and coil springs acting as the primary suspension.

2.5.7. Rubber Suspension

Steel springs provide a solid and reliable cushion for vehicle suspension but steel is heavy and requires maintenance because of wear and rust. Rubber however, if it could be produced with sufficient strength and durability, could perform the same function and it was used for minor parts of steel suspension systems from the late 19th century. Then, in the 1950s, some EMU trains were equipped with rubber packs replacing the steel in both primary and secondary suspension positions.

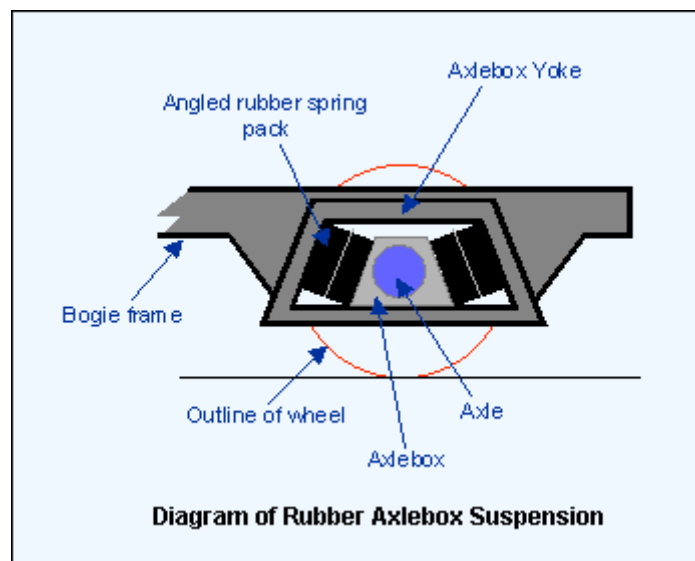

The axlebox is specially shaped, as shown here, to allow the fitting of rubber packs at an angle which will allow the forces to be transmitted to the bogie frame. In some designs used by the London Underground for many years, a cast steel yoke was provided to carry the axlebox and rubber chevrons which formed the suspension packs. The yoke was adjustable (not shown) relative to the bogie frame to permit some variation in its position to compensate for wheel wear.

Bolster suspensions were also redesigned at this time to allow rubber to be used instead of steel. Angled rubber packs, shaped like chevrons like the axlebox suspension, replaced the traditional steel springs and were quite successful until they were superseded in later designs by air springs.

Although successful in lighter applications, rubber suspensions can require careful design to be an effective and reliable alternative to steel because sometimes strange effects on other parts of a train can appear. One well documented case, in London Underground, describes how the performance of traction motor brushes deteriorated when rubber suspension was introduced in the early 1960s. Extensive trials were needed before the

cause and the cure, a modified form of motor brush tension spring, was finally discovered.

2.5.8. Air Suspension

It was only a matter of time before trains began using compressed air in their suspension system. They first appeared in the 1960s and were considered somewhat of a novelty at the time but, nowadays, air suspension is a standard fitting for passenger vehicles.

Apart from the provision of a better ride, air suspension has one additional feature rare on conventional steel or rubber suspension systems the ability to provide an accurate load/weight signal which can be used to modify the acceleration and braking of a multiple unit train. A diagrammatic arrangement of an air sprung bogie is shown below.

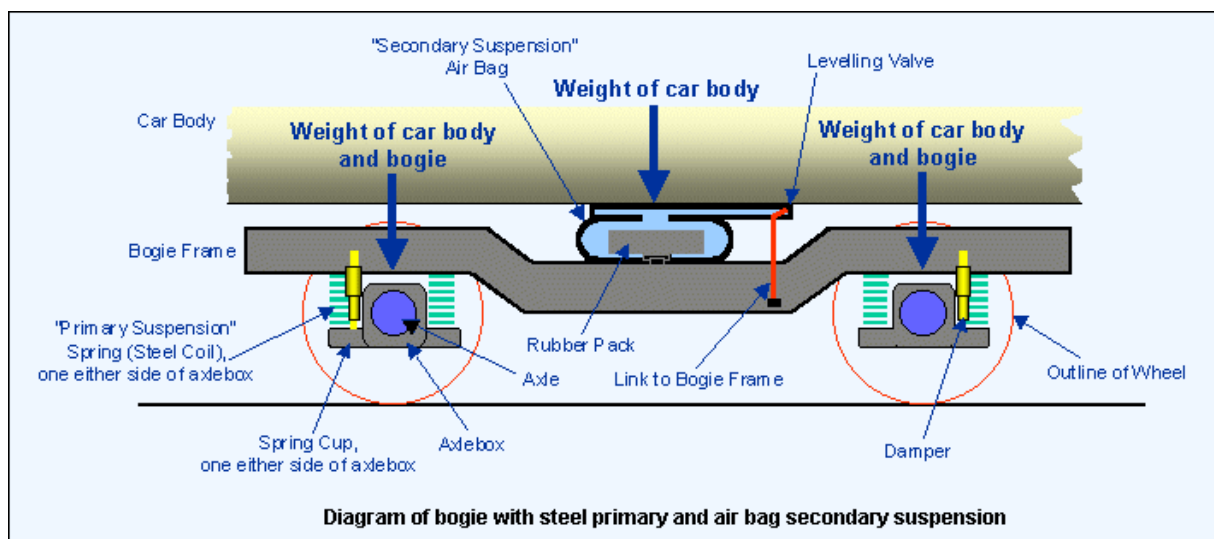

The weight of the car body (well, half of it, since the other half is carried by the other bogie) rests on the air bag, which is mounted on the top of the bogie frame. Compressed air is fed into the air bag through a levelling valve attached to the underside of the car body. The valve is operated by a lever attached to one end of a link, whose other end is fixed to the bogie frame. Any vertical movement between the car body and the bogie is detected by the lever which adjusts the levelling valve accordingly.

When the load on the car is changed at a station by passengers boarding and alighting, the weight of the body changes and the levelling valve adjusts the air pressure in the air bags to match. The effect is that the car body maintains almost a constant height from rail level, regardless of load. I say almost a constant height because the primary springs will depress to some degree with the additional load. If the car load is reduced, the levelling valve will allow excess air pressure to escape. This can sometimes be heard as an intermittent gentle hissing from under the cars at a terminus as all the passengers alights from a modern EMU.

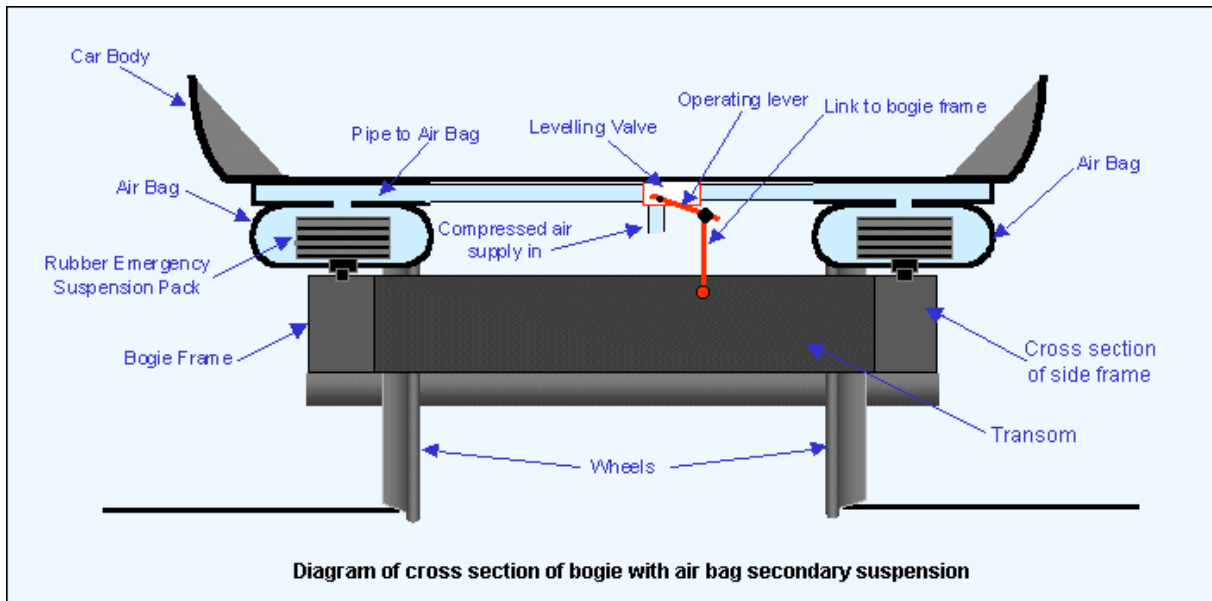

In this transverse view of a car with air suspension, the two air bags provided on a bogie can be seen. Inside each is a solid rubber suspension pack sufficiently strong to carry the suspension load, retained in case the air bag should burst or the air supply is lost.

One other feature of air suspension systems is that they can only alter the air bag pressure when the train is stationary. Constant changes of vehicle height would cause excessive bouncing if the system operated while the train was running. The levelling valve is automatically locked out of use when the train is moving or when the doors are closed depending on design.

This type of arrangement often uses a bolsterless truck or bogie, as shown in the diagrams above. It is a very simple design where the bogie frame is fabricated, usually in welded box-sections, into the form of the letter H. The crossbar of the H is where the bolster would be. It is called the transom. Instead of being suspended on springs it is solid with the side pieces. The car body (secondary) suspension is through the air bags mounted on the ends of the "crossbar" of the H. This type of bogie is now popular on passenger rolling stock.

2.6. PBL 90 ELECTRO-PNEUMATIC BRAKE CONTROL SYSTEM

2.6.1. Background

This is a simplified description of the air brake control system known as PBL 90. It is based on the UIC standard and is now used on some locomotives in the UK. It is assumed that if you have chosen this page, you probably have a good understanding of train braking systems in general and of air brakes in particular.

2.6.2. Introduction

The PBL 90 electro-pneumatic system is a Brake Control Panel (type PBL 90) mounted inside the equipment compartment, usually on the brake frame. The Brake Control Panel performs the function of the driver's brake valve on a conventional British locomotive and is standard equipment on the SNCF and SNCB. In French it is known as the "Robinet de Mechanicien" (driver's brake valve).

The principle of operation of the Brake Control Panel is that it transfers the driver's braking commands (or those of an ATO system should it ever be fitted), which originate as electrical signals, into pneumatic signals to control the pressure in the brake pipe. It also transmits the signals electrically along the train to provide electro-pneumatically assisted brake control on each vehicle.

The Brake Control Panel is also designed to respond automatically to unplanned or emergency losses of brake pipe pressure to ensure that such incidents cause the train to stop as quickly as possible.

In order to simplify understanding of the Brake Control Panel, this descriptive paper begins with a series of simplified schematics which show the panel with only its principal parts.

2.6.3. The Parts of the Brake Control Panel

The following diagram shows a simplified schematic of the brake control panel and its connections to the Main Brake Handle as Set Up mode is initiated. The Application and Release Valves are energised and the Main Relay Valve charges the Brake Pipe up to 3 Bar.

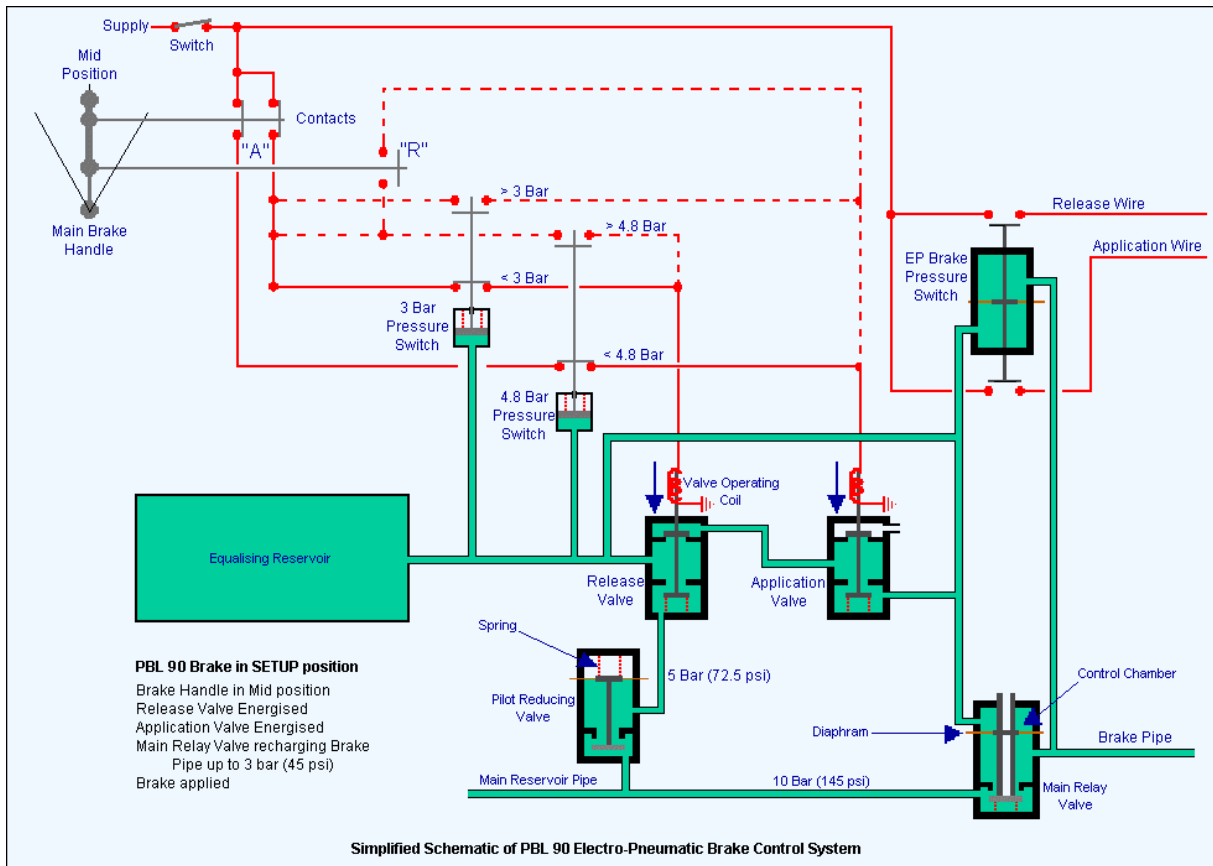

The locomotive is being prepared for service and the brake control system is being set up. The Brake Control Panel is provided with a connection to the Main Reservoir Pipe and is supplied with air from that pipe at 10 bar. There are also connections to the Brake Pipe and the Equalising Reservoir.

The principal components of the Brake Control Panel are as follows:

A Pilot Reducing Valve which converts air from the Main Reservoir at 10 bar to a pressure of 5 bar the control pressure required for the maximum pressure of 5 bar normally allowed in the Brake Pipe.

An Equalising Reservoir, not actually mounted on the Brake Control Panel, provides a volume reservoir by means of which Brake Pipe pressure is regulated. Variation of the pressure in the Equalising Reservoir will cause a corresponding variation of pressure in the Brake Pipe.

A Main Relay Valve which responds to changes in Equalising Reservoir pressure to control the supply of air to, and the exhaust of air from the Brake Pipe. If the Equalising Reservoir pressure in the control chamber at the top of the valve becomes greater than that in the Brake Pipe, the valve will open to allow the Main Reservoir supply to recharge the Brake Pipe. If the control chamber pressure is lower than that of the Brake Pipe, the

valve will lift and open an exhaust to discharge Brake Pipe pressure. When the control chamber and Brake Pipe pressures are equal, both the supply and exhaust ports of the valve are closed and the Brake Pipe pressure will remain unchanged.

A Release Magnet Valve which, when energised, connects the 5 bar output from the Pilot Reducing Valve to the Equalising Reservoir and to the upper chamber of the Main Relay Valve. When de-energised, the valve is lifted by a spring.

An Application Magnet Valve which, when energised, prevents a loss of Equalising Reservoir pressure. When de-energised with the Release Valve, it allows Equalising Reservoir air to escape and cause a reduction in Brake Pipe pressure. When de-energised, the valve is lifted by a spring.

A 3 Bar Pressure Switch which ensures that a minimum pressure of 3 bar is maintained in the Equalising Reservoir (and thus the Brake Pipe). This provides an emergency pneumatic control pressure for the Brake Pipe. It should be noted that, under normal conditions, a pressure drop to a level of 3 bar in the Brake Pipe is sufficient to give maximum brake effort. A further reduction will not increase the brake effort.

A 4.8 Bar Pressure Switch which is used to overcome small leaks to maintain the Brake Pipe pressure at a fully charged level.

An E.P. Brake Pressure Switch which detects brake pipe pressure and gives electrical signals along the e.p. control train wires to allow remote control of local control units on other vehicles with e.p. equipment.

2.6.4. Set-up

On a 'dead' locomotive the Brake Pipe pressure will be at zero because the Emergency Valve (not shown) is de-energised whilst the locomotive is shut down. When "Set Up" is initiated, the Emergency, Application and Release Valves are energised. The Release Valve is energised through the closed contacts "A" and those of the 3 Bar Pressure Switch. The Application Valve is energised through closed contacts "A" and the <4.8 Bar contacts of the 4.8 Bar Pressure Switch.

Energising the Release Valve causes compressed air, supplied at 5 Bar from the Pilot Reducing Valve, to pass to the Equalising Reservoir and to the upper chamber of the Main Relay Valve. The pressure in the upper chamber of the Main Relay Valve, being greater than that in the Brake Pipe, causes the port at the base of the valve to open and allows the Main Reservoir air supply to charge the Brake Pipe until it reaches a pressure of 3 bar.

2.6.5. Set-up Complete

When the brake pipe has reached the 3 bar pressure level, it can be said that the set-up is complete. The control system looks like this:

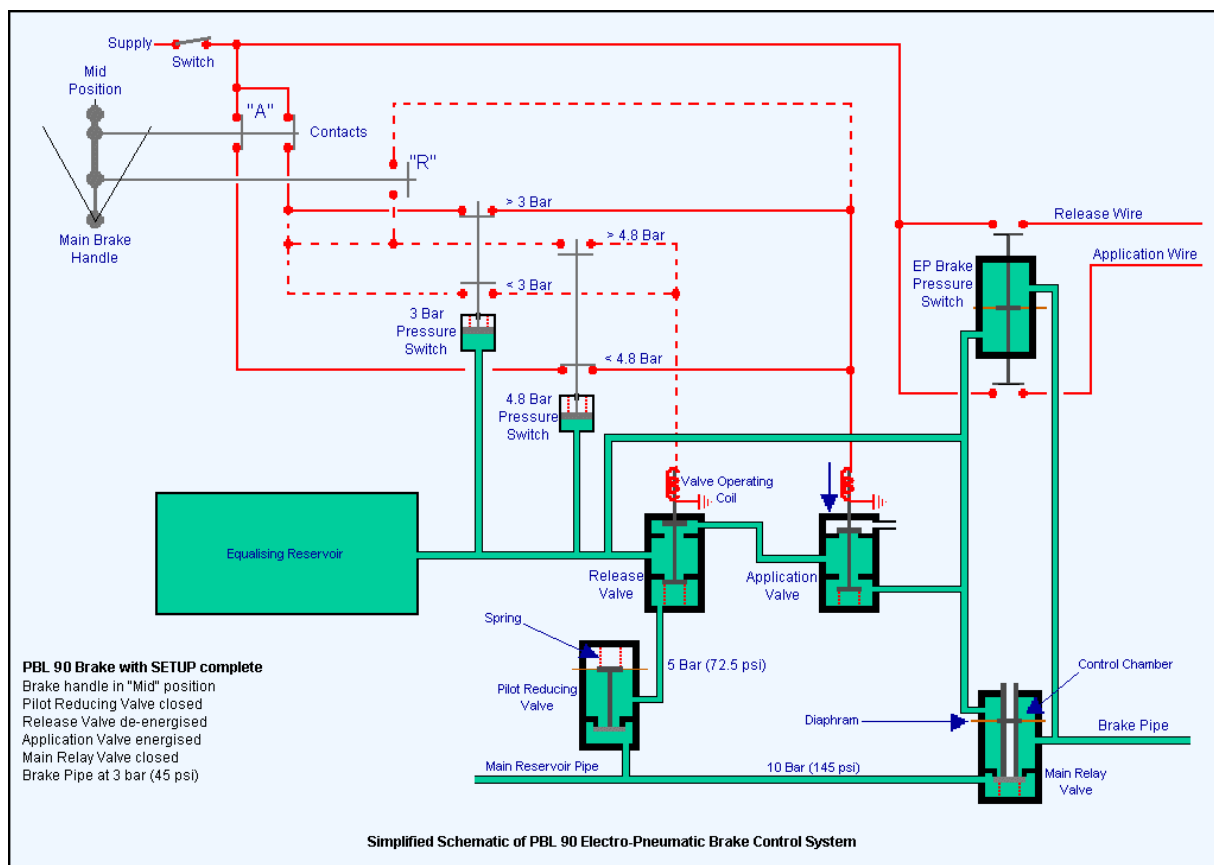

When the pressure in the Equalising Reservoir reaches 3 Bar, the 3 Bar Pressure Switch contacts open and cause the Release Valve to de-energise, closing off the supply from the Pilot Reducing Valve. The Application Valve remains energised.

When the pressure in the Brake Pipe reaches 3 Bar, the Equalising Reservoir pressure detected in the Main Relay Valve equalises with that of the Brake Pipe and the port at the base of the valve closes under spring pressure. The air pressure in the Brake Pipe now remains at 3 Bar. The Brake Pipe pressure is low enough to ensure that the brake remains applied.

2.6.6. Release

To release the Main brake, the Brake Pipe must be charged to a pressure greater than 4.8 Bar. This is done by selecting the Release position of the Main Brake handle. The handle must be held in this position against its spring pressure until the Equalising Reservoir gauge indicates 4.8 Bar. The Brake Pipe pressure will then rise to 5 bar under the control of the Pilot Reducing Valve. For Release, the control switches and valves are reconfigured to the positions shown in the diagram below:

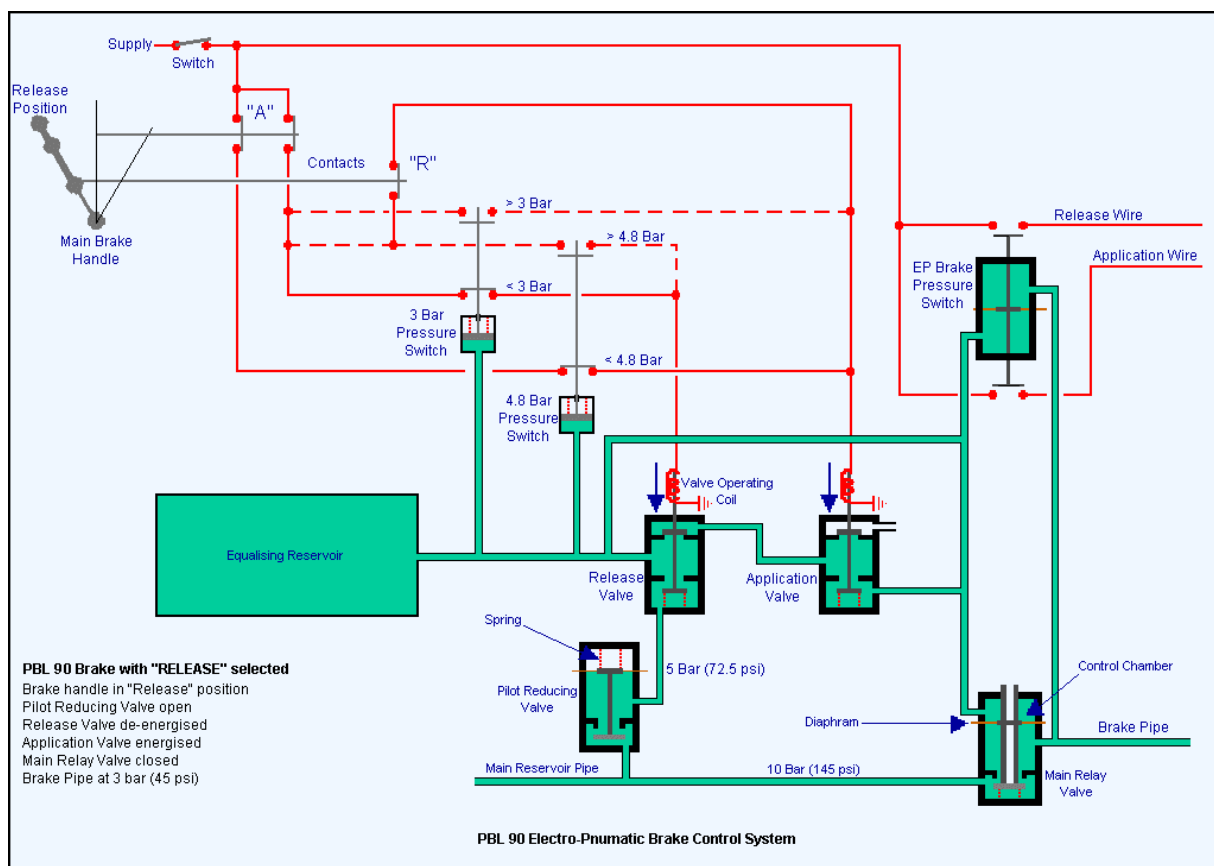

When the Main Brake Handle is moved to the Release position, contact "R" closes and causes the Release Valve to energise. The Application Valve will already be energised if

the Brake Pipe pressure is below 4.8 bar (Contacts 'A' closed and <4.8 bar contacts closed).

With both the Release and Application Valves energised, the Brake Pipe will begin to charge in the same way as occurs in Set Up mode. When the Equalising Reservoir pressure reaches 4.8 Bar, the <4.8 Bar contacts will open and the >4.8 Bar contacts will close. This will cause the Application Valve to de-energise but the Release Valve remains energised (through the >4.8 bar contacts) and open to allow the Brake Pipe to charge up to 5 bar under the control of the output pressure of the Pilot Reducing Valve.

2.6.7. Running

When release of the brakes is complete, the driver can allow the brake handle to return to the mid position and set the brake system to the "Running" position. The brakes remain released and the brake pipe pressure is maintained at the 4.8 bar pressure automatically as shown in the next diagram, unless a rapid discharge of the pipe occurs or the Application position is selected:

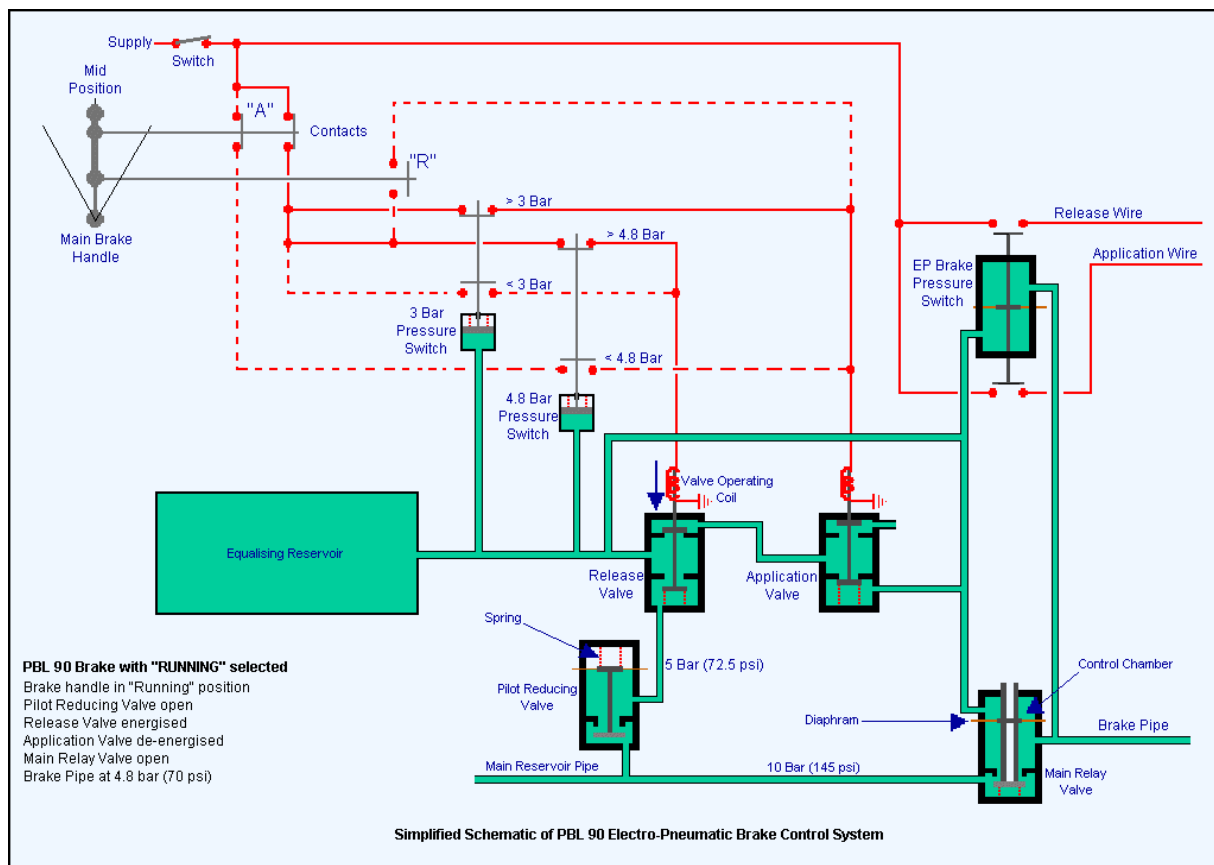

During normal running with the brake released and the Main Brake Handle in the Mid position, the Release Valve is held open by the contacts 'A' and the >4.8 contacts of the 4.8 Bar Pressure Switch. The energised Release Valve allows an upper level of 5 Bar to

be maintained in the Brake Pipe under the control of the output pressure of the Pilot Reducing Valve.

The purpose of this setting is to allow the brake control to automatically maintain brake pipe pressure against any small leaks or losses in the brake pipe. This prevents the brakes from "leaking on" and stopping the train unnecessarily.

2.6.8. Application

In order to apply the train brakes, it is necessary to reduce the pressure in the Brake Pipe to below 4.8 bar. This will occur when the Main Brake Handle is moved to the Application position (against spring pressure) causing contacts 'A' to open and de-energise both Application and Release Valves, regardless of their former state. The brake control now appear as in the diagram below:

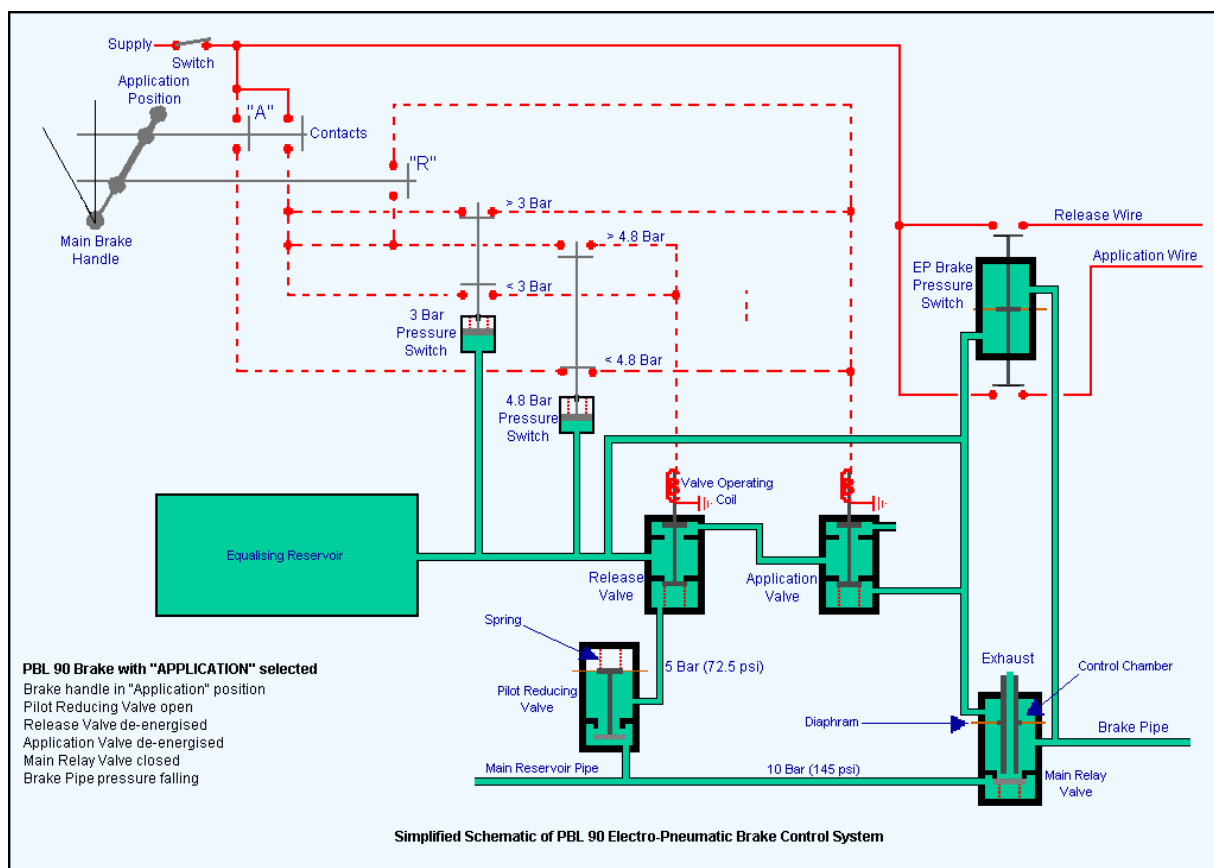

With the Application and Release Valves de-energised, air escapes through the Application Valve exhaust from the Equalising Reservoir and the upper chamber of the Main Relay Valve so that the pressure in the Brake Pipe becomes greater than that in the upper chamber and opens the valve to exhaust the Brake Pipe. The reduction in the Brake Pipe pressure causes the brakes on the train to apply.

Because the Release Valve is de-energised, the connection between the Pilot Reducing Valve and the Equalising Reservoir is closed to prevent the loss of air from the Equalising Reservoir being replaced.

2.6.9. Maintaining a Constant Brake

Once the desired level of braking is reached, the driver should allow the brake handle to return to the Mid position. This will energise the Application Valve through closed contacts 'A' and the <4.8 bar contacts of the 4.8 bar pressure switch. The Release Valve remains de-energised (see diagram below).

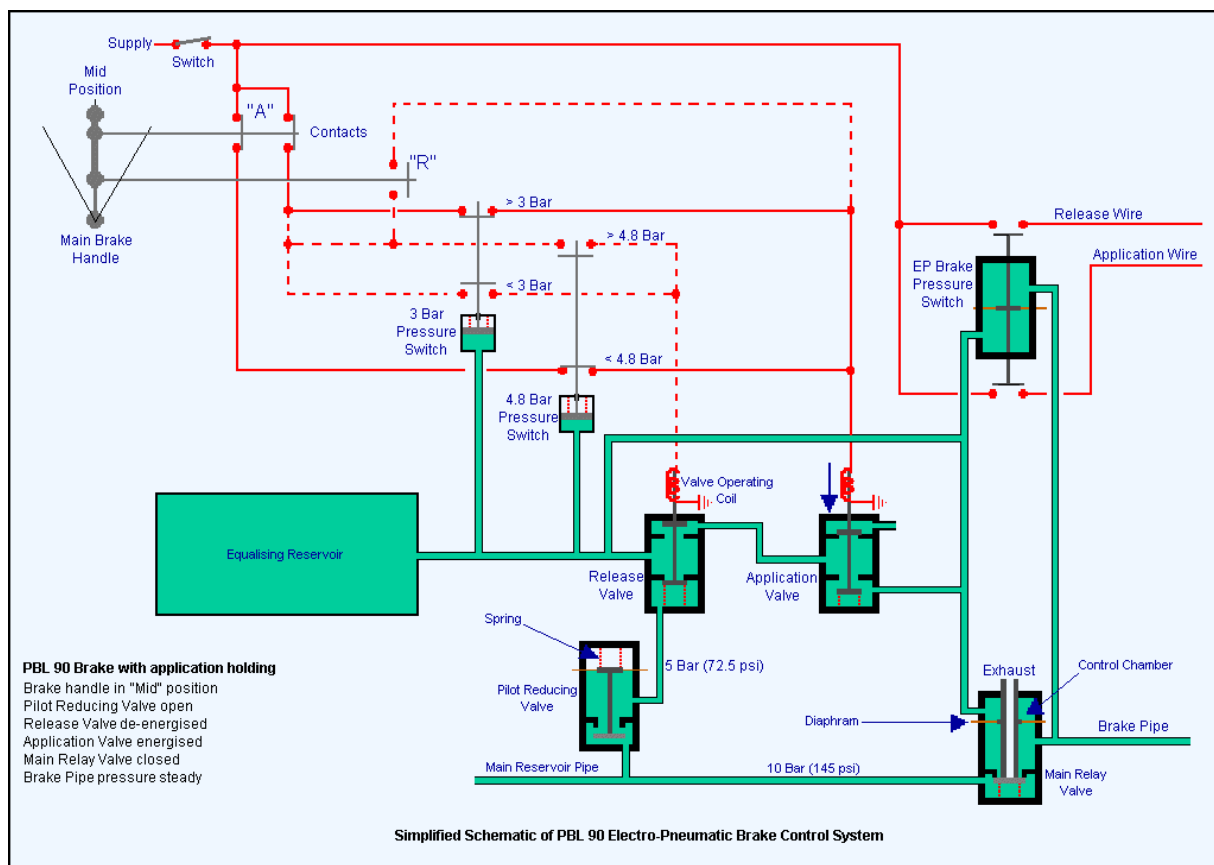

With the Application Valve energised, the exhausting of the upper chamber of the Main Relay Valve ceases and the exhaust port of the valve will close when the Brake Pipe pressure equalises with that in the upper chamber. The Brake Pipe pressure will now be held at a constant level, as will the brake effort on the train.

2.6.10. Partial or Full Release

If the driver requires a full release of the brake, he must move the Main Brake Handle from the Mid position to the Release position. The brake control panel will then appear as described above under [Release](#) and the Brake Pipe pressure will restore to 5 bar.

If the driver requires a partial release of the brake to reduce the retardation effort but still maintain an application, he must move the Main Brake Handle to the Release position until the required reduction in brake effort is achieved, then restore the handle to the Mid position. The Mid position must be selected before the Brake Pipe pressure reaches 4.8 bar otherwise the train brakes will be fully released.

When the Main Brake Handle is returned to the Mid position, the Release Valve will be de-energised by the opening of the contacts 'R'. The Application Valve will remain energised. Recharging of the Equalising Reservoir will cease and the supply of Main Reservoir air to the Brake Pipe will stop as soon as the pressure in the upper chamber of the Main Relay Valve equalises with that in the Brake Pipe.

2.6.11. Electro-Pneumatic Assistance

In addition to providing the driver with a means of controlling the pressure in the Brake Pipe from the locomotive, the Brake Control Panel is equipped with a pressure switch (the EP Brake Pressure Switch) which provides electro-pneumatic control of the brakes on each vehicle equipped with electro-pneumatic brake valves. The pressure switch detects differences in pressure between the Equalising Reservoir and the Brake Pipe and sends corresponding electrical signals to either an Application or Release Wire running the length of the train. The brake control equipment on each vehicle responds to these signals to apply or release the brake.

When the application position is selected, the Equalising Reservoir pressure falls below that of the Brake Pipe. The difference in pressure unbalances the EP Brake Pressure Switch and causes a contact to close and energise the application train wire. This results in a local brake application on each vehicle on the train.

When the pressure in the Equalising Reservoir and the Brake Pipe is equal, as during a constant level of brake application (see [above](#)), the EP Brake Pressure Switch achieves a state of equilibrium and the feed to the Application wire is broken. This holds the existing level of brake on individual vehicles.

When the Release position is selected (see [above](#)), the pressure in the Equalising Reservoir rises above that in the brake pipe causing the EP Brake Pressure Switch to unbalance and close a contact in the Release train wire to release the brakes on individual vehicles.

2.7. AIR BRAKES

2.7.1 Introduction

The air brake is the standard, fail-safe, train brake used by railways all over the world. In spite of what you might think, there is no mystery to it. It is based on the simple physical properties of compressed air. So here is a simplified description of the air brake system.

2.7.3. Operation on Each Vehicle

2.7.3.1. Release

2.7.3.2. Application

2.7.3.3. Lap

2.7.3.4. Additional Features of the Air Brake

2.7.3.5. Emergency Air Brake

2.7.3.6. Emergency Reservoirs

2.7.3.7. Distributors

2.7.3.8. Two-Pipe Systems

2.7.3.9. Self-Lapping Brake Valves

2.7.3.10. Other Air Operated Systems

2.7.3.11. Comment.

2.7.2. Basics

A moving train contains energy, known as kinetic energy, which needs to be removed from the train in order to cause it to stop. The simplest way of doing this is to convert the energy into heat. The conversion is usually done by applying a contact material to the rotating wheels or to discs attached to the axles. The material creates friction and converts the kinetic energy into heat. The wheels slow down and eventually the train stops. The material used for braking is normally in the form of a block or pad.

The vast majority of the world's trains are equipped with braking systems which use compressed air as the force to push blocks on to wheels or pads on to discs. These systems are known as "air brakes" or "pneumatic brakes". The compressed air is transmitted along the train through a "brake pipe". Changing the level of air pressure in the pipe causes a change in the state of the brake on each vehicle. It can apply the brake, release it or hold it "on" after a partial application. The system is in widespread use throughout the world.

2.7.3. The Principal Parts of the Air Brake System

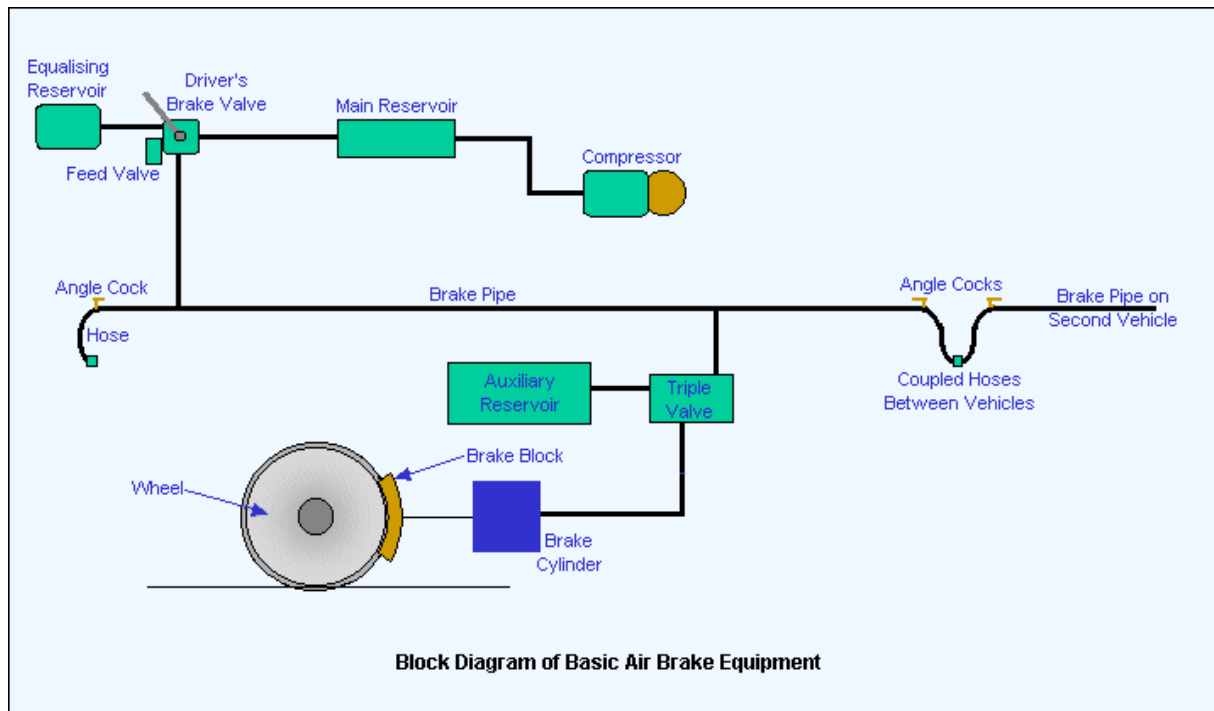

The diagram shows the principal parts of the air brake system and these are described below.

Compressor

The pump which draws air from atmosphere and compresses it for use on the train. Its principal use is for the air brake system, although compressed air has a number of other uses on trains.

Main Reservoir

Storage tank for compressed air for braking and other pneumatic systems.

Driver's Brake Valve

The means by which the driver controls the brake. The brake valve will have (at least) the following positions: "Release", "Running", "Lap" and "Application" and "Emergency". There may also be a "Shut Down" position, which locks the valve out of use.

The "Release" position connects the main reservoir to the brake pipe . This raises the air pressure in the brake pipe as quickly as possible to get a rapid release after the driver gets the signal to start the train.

In the "Running" position, the feed valve is selected. This allows a slow feed to be maintained into the brake pipe to counteract any small leaks or losses in the brake pipe, connections and hoses.

"Lap" is used to shut off the connection between the main reservoir and the brake pipe and to close off the connection to atmosphere after a brake application has been made. It can only be used to provide a partial application. A partial release is not possible with the common forms of air brake, particularly those used on US freight trains.

"Application" closes off the connection from the main reservoir and opens the brake pipe to atmosphere. The brake pipe pressure is reduced as air escapes. The driver (and any observer in the know) can often hear the air escaping.

Most driver's brake valves were fitted with an "Emergency" position. Its operation is the same as the "Application" position, except that the opening to atmosphere is larger to give a quicker application.

Feed Valve

To ensure that brake pipe pressure remains at the required level, a feed valve is connected between the main reservoir and the brake pipe when the "Running" position is selected. This valve is set to a specific operating pressure. Different railways use different pressures but they generally range between 65 and 90 psi (4.5 to 6.2 bar).

Equalising Reservoir

This is a small pilot reservoir used to help the driver select the right pressure in the brake pipe when making an application. When an application is made, moving the brake valve handle to the application position does not discharge the brake pipe directly, it lets air out of the equalising reservoir. The equalising reservoir is connected to a relay valve (called the "equalising discharge valve" and not shown in my diagram) which detects the drop in pressure and automatically lets air escape from the brake pipe until the pressure in the pipe is the same as that in the equalising reservoir.

The equalising reservoir overcomes the difficulties which can result from a long brake pipe. A long pipe will mean that small changes in pressure selected by the driver to get a low rate of braking will not be seen on his gauge until the change in pressure has stabilised along the whole train. The equalising reservoir and associated relay valve allows the driver to select a brake pipe pressure without having to wait for the actual pressure to settle down along a long brake pipe before he gets an accurate reading.

Brake Pipe

The pipe running the length of the train, which transmits the variations in pressure required to control the brake on each vehicle. It is connected between vehicles by flexible hoses, which can be uncoupled to allow vehicles to be separated. The use of the air system makes the brake "fail safe", i.e. loss of air in the brake pipe will cause the brake to apply. Brake pipe pressure loss can be through a number of causes as follows:

- A controlled reduction of pressure by the driver
- A rapid reduction by the driver using the emergency position on his brake valve
- A rapid reduction by the conductor (guard) who has an emergency valve at his position
- A rapid reduction by passengers (on some railways) using an emergency system to open a valve
- A rapid reduction through a burst pipe or hose
- A rapid reduction when the hoses part as a result of the train becoming parted or derailed.

Angle Cocks

At the ends of each vehicle, "angle cocks" are provided to allow the ends of the brake pipe hoses to be sealed when the vehicle is uncoupled. The cocks prevent the air being lost from the brake pipe.

Coupled Hoses

The brake pipe is carried between adjacent vehicles through flexible hoses. The hoses can be sealed at the outer ends of the train by closing the angle cocks.

Brake Cylinder

Each vehicle has at least one brake cylinder. Sometimes two or more are provided. The movement of the piston contained inside the cylinder operates the brakes through links called "rigging". The rigging applies the blocks to the wheels. Some modern systems

use disc brakes. The piston inside the brake cylinder moves in accordance with the change in air pressure in the cylinder.

Auxiliary Reservoir

The operation of the air brake on each vehicle relies on the difference in pressure between one side of the triple valve piston and the other. In order to ensure there is always a source of air available to operate the brake, an "auxiliary reservoir" is connected to one side of the piston by way of the triple valve. The flow of air into and out of the auxiliary reservoir is controlled by the triple valve.

Brake Block

This is the friction material which is pressed against the surface of the wheel tread by the upward movement of the brake cylinder piston. Often made of cast iron or some composition material, brake blocks are the main source of wear in the brake system and require regular inspection to see that they are changed when required.

Many modern braking systems use air operated disc brakes. These operate to the same principles as those used on road vehicles.

Brake Rigging

This is the system by which the movement of the brake cylinder piston transmits pressure to the brake blocks on each wheel. Rigging can often be complex, especially under a passenger car with two blocks to each wheel, making a total of sixteen. Rigging requires careful adjustment to ensure all the blocks operated from one cylinder provide an even rate of application to each wheel. If you change one block, you have to check and adjust all the blocks on that axle.

Triple Valve

The operation of the brake on each vehicle is controlled by the "triple valve", so called because it originally comprised three valves - a "slide valve", incorporating a "graduating valve" and a "regulating valve". It also has functions - to release the brake, to apply it and to hold it at the current level of application. The triple valve contains a slide valve which detects changes in the brake pipe pressure and rearranges the connections inside the valve accordingly. It either:

- recharges the auxiliary reservoir and opens the brake cylinder exhaust,
- closes the brake cylinder exhaust and allows the auxiliary reservoir air to feed into the brake cylinder

- or holds the air pressures in the auxiliary reservoir and brake cylinder at the current level.

The triple valve is now usually replaced by a [distributor](#) a more sophisticated version with built-in refinements like graduated release.

2.7.4 Operation On Each Vehicle

2.7.4 1. Break Release

This diagram shows the condition of the brake cylinder, triple valve and auxiliary reservoir in the brake release position.

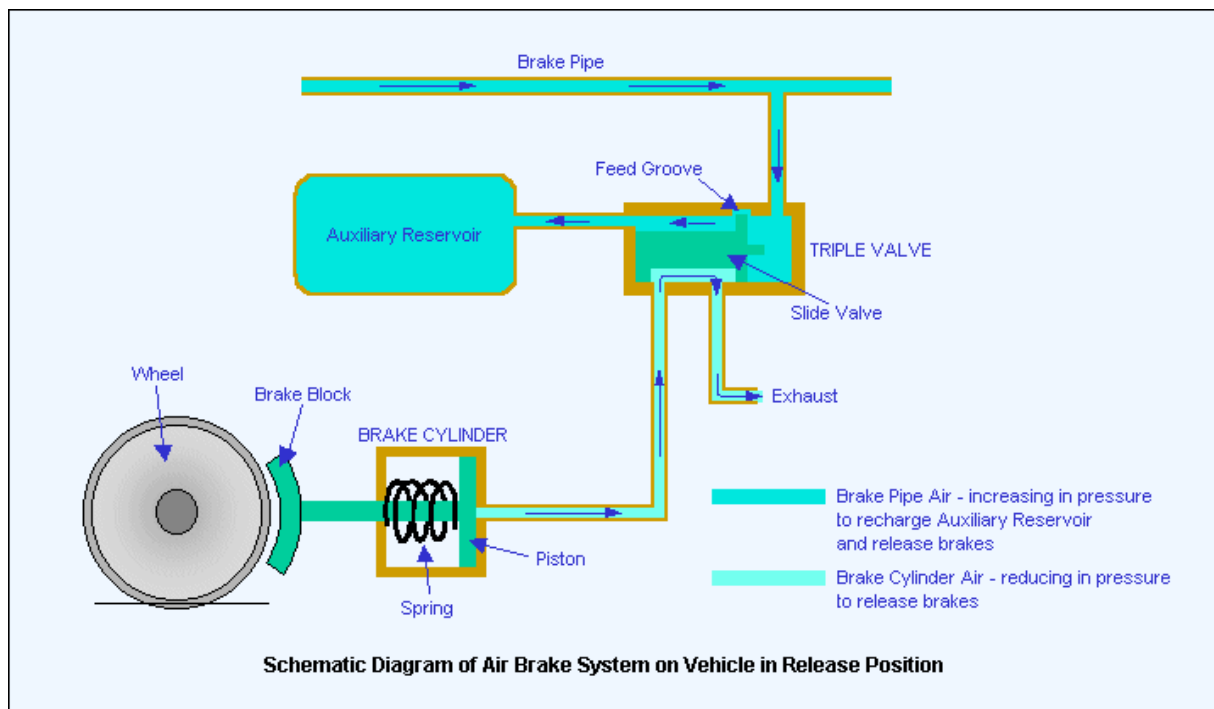

The driver has placed the brake valve in the "Release" position. Pressure in the brake pipe is rising and enters the triple valve on each car, pushing the slide valve provided inside the triple valve to the left. The movement of the slide valve allows a "feed groove" above it to open between the brake pipe and the auxiliary reservoir, and another connection below it to open between the brake cylinder and an exhaust port. The feed groove allows brake pipe air pressure to enter the auxiliary reservoir and it will recharge it until its pressure is the same as that in the brake pipe. At the same time, the connection at the bottom of the slide valve will allow any air pressure in the brake cylinder to escape through the exhaust port to atmosphere. As the air escapes, the spring in the cylinder will push the piston back and cause the brake blocks to be removed from contact with the wheels. The train brakes are now released and the auxiliary reservoirs are being replenished ready for another brake application.

2.7.4 2. Brake Application

This diagram shows the condition of the brake cylinder, triple valve and auxiliary reservoir in the brake application position.

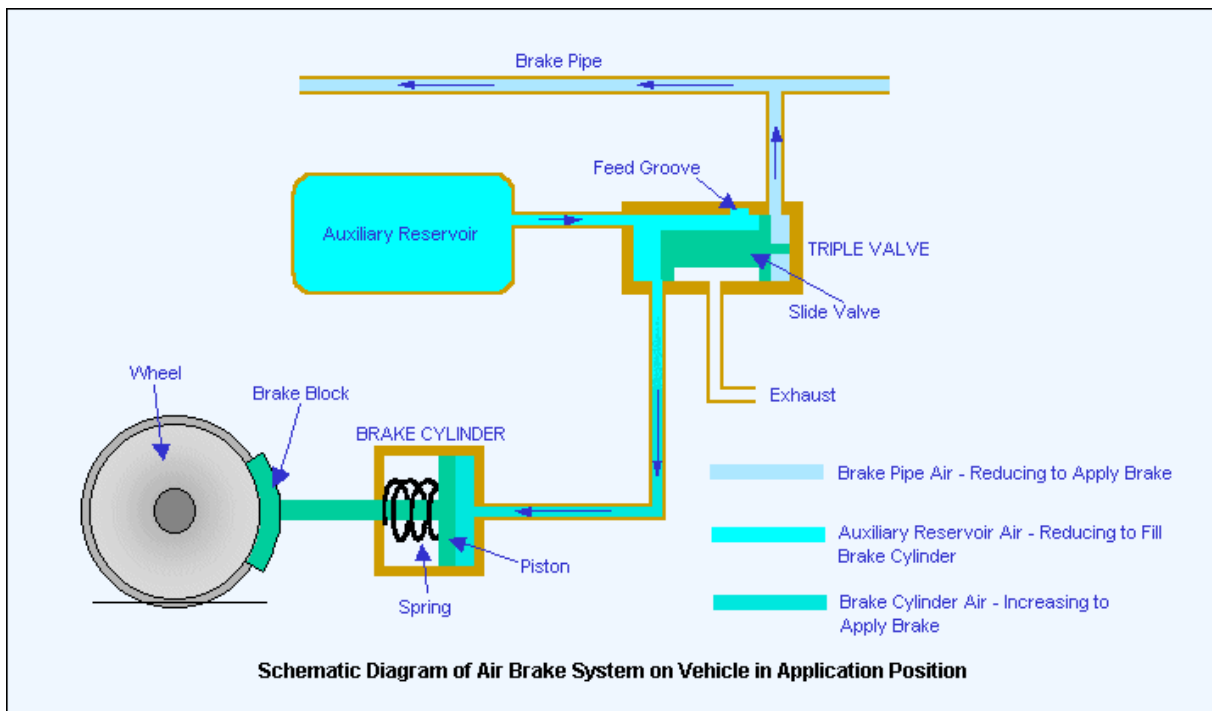

The driver has placed the brake valve in the "Application" position. This causes air pressure in the brake pipe to escape. The loss of pressure is detected by the slide valve in the triple valve. Because the pressure on one side (the brake pipe side) of the valve has fallen, the auxiliary reservoir pressure on the other side has pushed the valve (towards the right) so that the feed groove over the valve is closed. The connection between the brake cylinder and the exhaust underneath the slide valve has also been closed. At the same time a connection between the auxiliary reservoir and the brake cylinder has been opened. Auxiliary reservoir air now feeds through into the brake cylinder. The air pressure forces the piston to move against the spring pressure and causes the brake blocks to be applied to the wheels. Air will continue to pass from the auxiliary reservoir to the brake cylinder until the pressure in both is equal. This is the maximum pressure the brake cylinder will obtain and is equivalent to a full application. To get a full application with a reasonable volume of air, the volume of the brake cylinder is usually about 40% of that of the auxiliary reservoir.

2.7.4 3. Lap

The purpose of the "Lap" position is to allow the brake rate to be held constant after a partial application has been made.

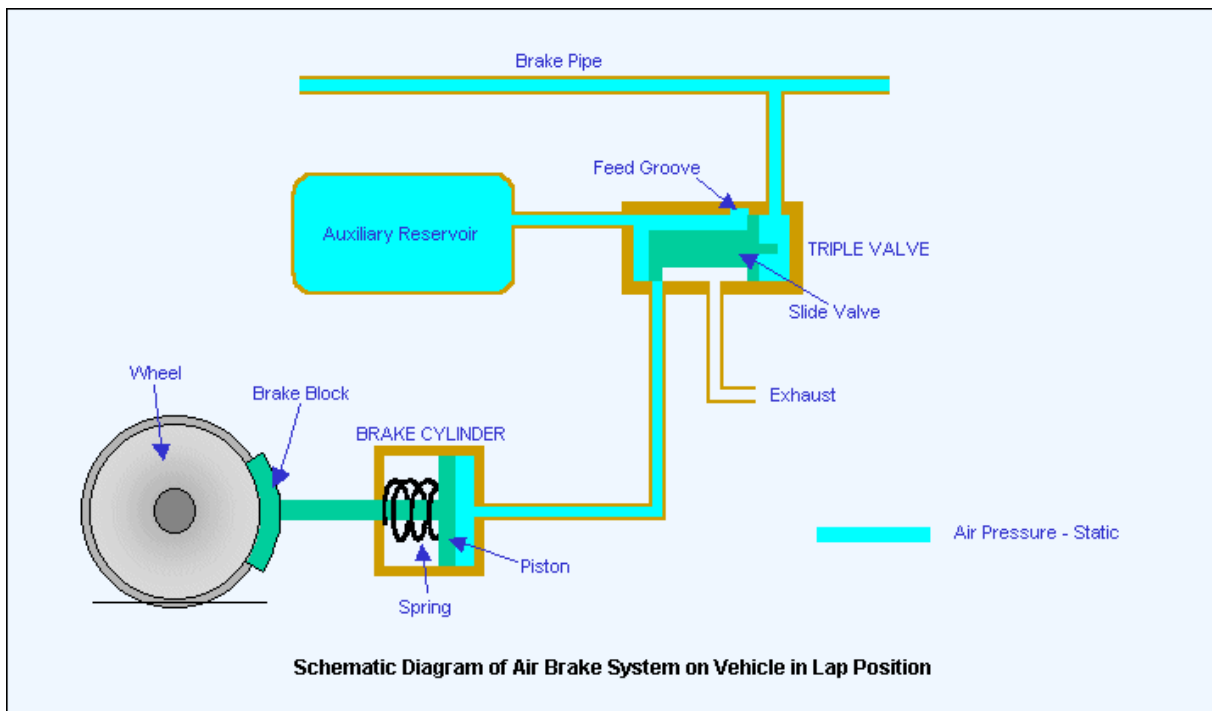

When the driver places the brake valve in the "Lap" position while air is escaping from the brake pipe, the escape is suspended. The brake pipe pressure stops falling. In each triple valve, the suspension of this loss of brake pipe pressure is detected by the slide valve because the auxiliary pressure on the opposite side continues to fall while the brake pipe pressure stops falling. The slide valve therefore moves towards the auxiliary reservoir until the connection to the brake cylinder is closed off. The slide valve is now half-way between its application and release positions and the air pressures are now in a state of balance between the auxiliary reservoir and the brake pipe. The brake cylinder is held constant while the port connection in the triple valve remains closed. The brake is "lapped".

Lap does not work after a release has been initiated. Once the brake valve has been placed in the "Release" position, the slide valves will all be moved to enable the recharge of the auxiliary reservoirs. Another application should not be made until sufficient time has been allowed for this recharge. The length of time will depend on the amount of air used for the previous application and the length of the train.

2.7.4.4. Additional Features of the Air Brake

What we have seen so far is the basics of the air brake system. Over the 130 years since its invention, there have been a number of improvements as described below

2.7.4.5. Emergency Air Brake

Most air brake systems have an "Emergency" position on the driver's brake valve. This position dumps the brake pipe air quickly. Although the maximum amount of air which can be obtained in the brake cylinders does not vary on a standard air brake system, the rate of application is faster in "Emergency". Some triple valves are fitted with sensor valves which detect a sudden drop in brake pipe pressure and then locally drop brake pipe pressure. This has the effect of speeding up the drop in pressure along the train it increases the "propagation rate".

2.7.4.6. Emergency Reservoirs

Some air brake systems use emergency reservoirs. These are provided on each car like the auxiliary reservoir and are recharged from the brake pipe in a similar way. However, they are only used in an emergency, usually being triggered by the triple valve sensing a sudden drop in brake pipe pressure. A special version of the triple valve (a distributor) is required for cars fitted with emergency reservoirs.

2.7.4.7. Distributors

A distributor performs the same function as the triple valve, it's just a more sophisticated version. Distributors have the ability to connect an emergency reservoir to the brake system on the vehicle and to recharge it. Distributors may also have a partial release facility, something not usually available with triple valves.

A modern distributor will have:

- a quick service feature where a small chamber inside the distributor is used to accept brake pipe air to assist in the transmission of pressure reduction down the train
- a reapplication feature allowing the brake to be quickly re-applied after a partial release
- a graduated release feature allowing a partial release followed by a holding of the lower application rate
- a connection for a variable load valve allowing brake cylinder pressure to adjust to the weight of the vehicle
- chokes (which can be changed) to allow variations in brake application and release times

- an inshot feature to give an initial quick application to get the blocks on the wheels
- brake cylinder pressure limiting
- auxiliary reservoir overcharging prevention.

All of these features are achieved with no electrical control. The control systems comprise diaphragms and springs arranged in a series of complex valves and passages within the steel valve block. Distributors with all these features will normally be provided on passenger trains or specialist high-speed freight vehicles.

2.7.4.8. Two Pipe Systems

A problem with the design of the standard air brake is that it is possible to use up the air in the auxiliary reservoir more quickly than the brake pipe can recharge it. Many runaways have resulted from overuse of the air brake so that no auxiliary reservoir air is available for the much needed last application. Read Al Krug's paper [North American Freight Train Brakes](#) for a detailed description of how this happens. The problem can be overcome with a two-pipe system as shown in the simplified diagram below.

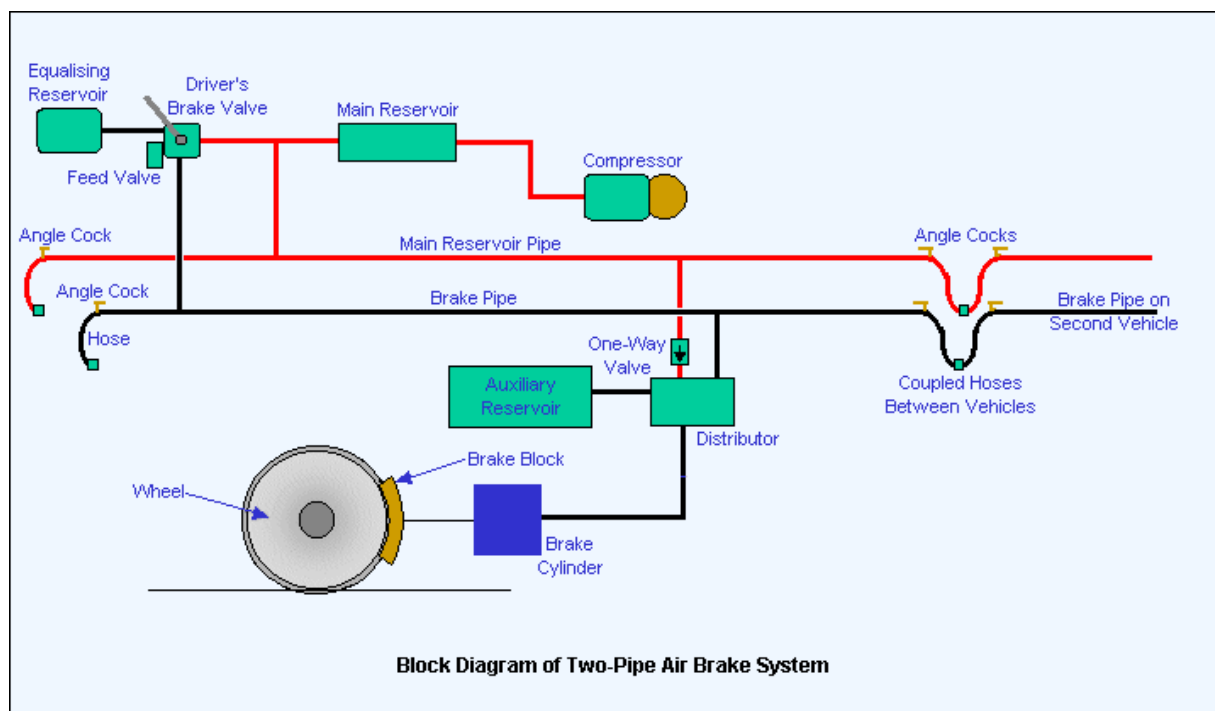

The second pipe of the two-pipe system is the main reservoir pipe. This is simply a supply pipe running the length of the train which is fed from the compressor and main reservoir. It performs no control function but it is used to overcome the problem of critical loss of pressure in the auxiliary reservoirs on each car. A connecting pipe, with a one-way valve, is provided between the main reservoir pipe and the auxiliary reservoir. The one-way valve allows air from the main reservoir pipe to top up the auxiliary

reservoir. The one-way feature of the valve prevents a loss of auxiliary reservoir air if the main reservoir pressure is lost.

Another advantage of the two-pipe system is its ability to provide a quick release. Because the recharging of the auxiliaries is done by the main reservoir pipe, the brake pipe pressure increase which signals a brake release is used just to trigger the brake release on each car, instead of having to supply the auxiliaries as well.

Two pipe systems have distributors in place of triple valves. One feature of the distributor is that it is designed to restrict the brake cylinder pressure so that, while enough air is available to provide a full brake application, there isn't so much that the brake cylinder pressure causes the blocks to lock the wheels and cause a skid. This is an essential feature if the auxiliary reservoir is being topped up with main reservoir air, which is usually kept at a higher pressure than brake pipe air.

Needless to say, fitting a second pipe to every railway vehicle is an expensive business so it is always the aim of the brake equipment designer to allow backward compatibility - in much the same way as new computer programs are usually compatible with older versions. Most vehicles fitted with distributors or two-pipe systems can be operated in trains with simple one-pipe systems and triple valves, subject to the correct set-up during train formation.

2.7.4.9. Self Lapping Brake Valves

Self lapping is the name given to a brake controller which is position sensitive, i.e. the amount of application depends on the position of the brake valve handle between full release and full application. The closer the brake handle is to full application, the greater the application achieved on the train. The brake valve is fitted with a pressure sensitive valve which allows a reduction in brake pipe pressure according to the position of the brake valve handle selected by the driver. This type of brake control is popular on passenger locomotives.

2.7.4.10. Other Air Operated Equipment

On an air braked train, the compressed air supply is used to provide power for certain other functions besides braking. These include door operation, whistles/horns, traction equipment, pantograph operation and rail sanders. For details, see [Auxiliary Equipment](#).

2.8. ELECTRICALLY CONTROLLED PNEUMATIC BRAKES

2.8.1. Introduction

A description, specially written by Randy Buchter of the Electronically Controlled Pneumatic brakes being used on various railroads in the US.

2.8.2. ECP Brakes - Background

A new form of electrical control of air braking is currently being tested by a number of railroads in the US. It is known as ECP and uses modern electronic techniques to overcome the problems of air braking on long freight trains.

The pure [air control brake system](#) invented by George Westinghouse in the 1860s and still used by almost all freight trains in the US and in many other parts of the world suffers from two main problems. It takes a long time for the air messages to travel along the train and there is no graduated release. For example, the delay for a reduction in train line pressure to travel from the leading locomotive to the rear of a 150 car consist can be 150 seconds. Also, you have to fully release the brake and wait for the supply reservoirs to recharge before you can reapply. Electrical control can overcome these difficulties.

ECP refers to Electronically Controlled Pneumatic brakes, key word being "Electronically" as opposed to "electrically". Older systems fitted to passenger trains, ([E-P brakes](#)) use several train wires to operate individual valves or variations in switching of the wires to control brakes. Most of these systems use a second train line for main reservoir air supplies and they do not have the built-in two-way communications that ECP systems have. A car in an ECP brake train can do a self-diagnosis and report the information to the engineer and it only requires the standard train line pipe.

Operation

There is a control box on top of the engineer's console. When he wants to apply brakes the engineer pushes the button until the readout shows the amount of brake cylinder pressure (or percentage of braking effort) he wants. He releases the button; the control unit then codes and sends the signal to all cars. They in turn receive and interpret the message. They then begin allowing compressed air from their reservoirs to go to the brake cylinder until the desired cylinder pressure is achieved. The microprocessors on the cars will continuously monitor brake cylinder pressure against leakage and maintain the desired pressure.

If the engineer wants to reduce brake cylinder pressure he simply pushes the release button until the desired level is indicated, either partial or full release. Again a signal is

coded and transmitted to the cars. The cars in turn do as commanded. If the engineer asks for only a partial reduction of braking effort, he can increase the effort again as needed without doing a full release first. The processor on the car is constantly monitoring brake pipe, reservoir tank and brake cylinder pressures.

When braking commands are not being transmitted, the head end (control) unit is sending out status messages. The last car in the train (which knows it is last due to the head end doing a train query and initialisation at start-up) will respond to each status message from the head end. All cars in the consist will monitor these messages, and if a car fails to receive three status messages in a row from either the head end or the rear end, it will assume that the train is broken in two or that the electrical line is broken. It will then initiate an emergency stop, while trying to tell the other cars and loco that it is doing so.

2.8.3. Power Sources

Each car has a rechargeable battery to provide the high power requirements when solenoids need to be activated. When the high power is not being used, the batteries will trickle recharge from the communications/power cable. (If the train uses radio communication the batteries will recharge while the car is in motion via an onboard generator creating power from the motion of the car, either an axle generator, or natural frequency vibration generator or some other type of device.)

The hardwired system uses roughly 25% of its signal capacity for brake commands and status messages. Distributed power, controlled via the same cable uses another 10-15%, leaving 60-65% of the signal capacity for special monitors on the car, such as bearing sensors, temperature sensors for reefers on tankers, pressure sensors for tankers, etc.

2.8.4. Manufacturers Systems

TSM, which was a subsidiary of Rockwell International, developed the first working ECP brake units. They are now owned by WABCO. In addition, Westinghouse Air Brake, New York Air Brake (a subsidiary of Knorr Corp.), GE/Harris and a small company called Zeftron, are developing ECP units.

TSM's first units worked in an "overlay" mode, where a module was placed between the air pilots and the actual valves, so that the system could work both ways. Zeftron started out working on an "emulator" brake valve, which totally eliminates the air pilots. The system, which must always be powered, looks for ECP commands. If it finds none, it monitors brake pipe pressure and behaves just like a standard air brake. If ECP command signals are present, the units behave like an ECP brake.

Because of the sequential operations of standard brakes, there is a flow control which limits how fast the air can flow into the brake cylinder. On ECP systems, because there is instantaneous reaction from all cars at once, these flow controls are not used. The lack of sequential activation and flow controls combined is what makes ECP brakes so responsive.

TSM is now introducing an emulator system. This enables cars fitted with it to work in ECP trains and non-ECP trains. New York Air Brake has a system available for sale in the very near future. Westinghouse Air Brake is playing it cool, waiting for all of the specs to be written and all of the bugs worked out before they commit to anything.

2.8.5. Benefits

Some of the benefits of ECP braking have already been mentioned; instantaneous response to the engineer's commands on all vehicles, graduated release of brakes and continuous replenishment of reservoirs. But there are other and more significant benefits for the industry as a whole.

With the new responsiveness of ECP braking, braking distances will be reduced. A range of 30 - 70% reduction has been quoted. This will allow shorter stopping distances and will, in turn, allow higher speeds. The improved train handling will reduce slack action, breakaways and derailments and will lead to a reduction in draft gear maintenance.

There may be a price to pay. Although the current view is that brake shoe and wheel wear will be reduced, it is easy to see that engineers will develop their handling skills with the new system and this will lead to higher speeds needing more and heavier brake applications. A wise railway management will recognise this and will review its speed limit zones to ensure the maximum benefits are obtained without excessive brake usage.

2.8.6. Developments

There was much discussion amongst experts regarding the need for an end-of-train (EOT) device or letting the last car act as the end-of-train beacon. It seems that the last word on EOT beacons was that there will be one!

There are committees that are developing specs right now to permit the addition of monitors onto cars. The monitors will have their own microprocessors and will only send a signal to the head end when something on the car is going out of specified limits. This keeps the communications line open for brake commands, loco commands, and emergency messages.

A further development will be the use of the electronic train line for diagnostics, where the head end position can be informed of hot boxes, car load temperatures, tanker pressures, wagon doors not closed, parking brake off/on and the like.

2.8.7. ECP Record

There was a record-breaking, 600 km round trip by a train fitted with ECP braking in Australia. On 28 June 1999, a train comprising 240 wagons, five GE Dash 8 diesel-electric locomotives and weighing 37,500 tonnes was equipped with the GE Harris EPx radio-based, electronic brake control system. It was the longest and heaviest train ever to be fitted with an ECP brake system. The locomotives were fitted with the same company's Locotrol remote locomotive control system. The train operated over the BHP Iron Ore line between Port Headland and Yandi Mine. *Source IRJ.*

2.9. ELECTRO-PNEUMATIC BRAKES

2.9.1. Introduction

Originally designed for subways or metros, the electro-pneumatic brake has more recently been used on main line passenger railways and some specialised freight operations. Its main advantage over the air brake is its speed of control and quick on-vehicle reaction times, giving instantaneous control of the whole train to the driver. Its speed of operation makes it ideal for [automatic train operation \(ATO\)](#). E.P. braking is not the same as ECP braking. ECP brakes have been introduced recently in an attempt to overcome the drawbacks of the air brake system on long freight trains. An article on this site here [ECP Brakes](#) has been written by Randy Buchter.

2.9.2. Background

Even the most modern, purely air brake systems rely on the transmission of an air signal along the brake pipe. This is initiated from the front of the train and has to be sent to all vehicles along the train to the rear. There will always be a time lapse (called the propagation rate) between the reaction of the leading vehicle and the reaction of one at the rear. This time lapse is a considerable restraint on operation. It causes the braking of vehicles to happen at different times along the train so that while some cars are slowing down, others are still trying to push, unbraked, from the rear. When releasing, the front of the train is pulling the rear, still braking, and causes stress to the couplers. Another drawback is the lack of a graduated release, an elusive goal for many years.

The introduction of electric traction and multiple unit control was the spur which eventually produced electrically controlled air brakes. The rise of rapid transit operations in cities, with their high volume and frequent stops and starts, meant that quick responses to brake commands and accurate stopping at stations was an essential ingredient in getting more efficiency. E-P brakes first appeared in the US. They were tried on the New York Subway in 1909 and then on London Underground in 1916.

2.9.3. Principles of the E-P Brake

There are many types of e-p brake systems in use today and most of them were developed as an "add-on" to the original air brake system and, as a result, incorporated some common principles in their design as follows:

- The e-p brake operates as the service brake while the air brake is retained for emergency use
- The e-p brake does not compromise the fail-safe or "vital" features of the air brake

- The air brake normally remains in the "Release" position, even while the e-p brake is in "Application" and the same brake cylinders are used.
- E-P brakes are invariably used on multiple unit passenger trains.
- E-P brakes use a number of train wires to control the electrically operated brake valves on each car.
- The train wires are connected to a brake "valve" or controller in the driver's cab.

E-P brakes should not be confused with ECP (Electronically Controlled Pneumatic) brakes. E-P brakes are used on multiple unit passenger trains whereas ECP brakes have been developed recently for use on freight trains. ECP brakes do not always require a train wire and, if they do, it is usually a single wire.

2.9.4. A Simple E-P Brake System

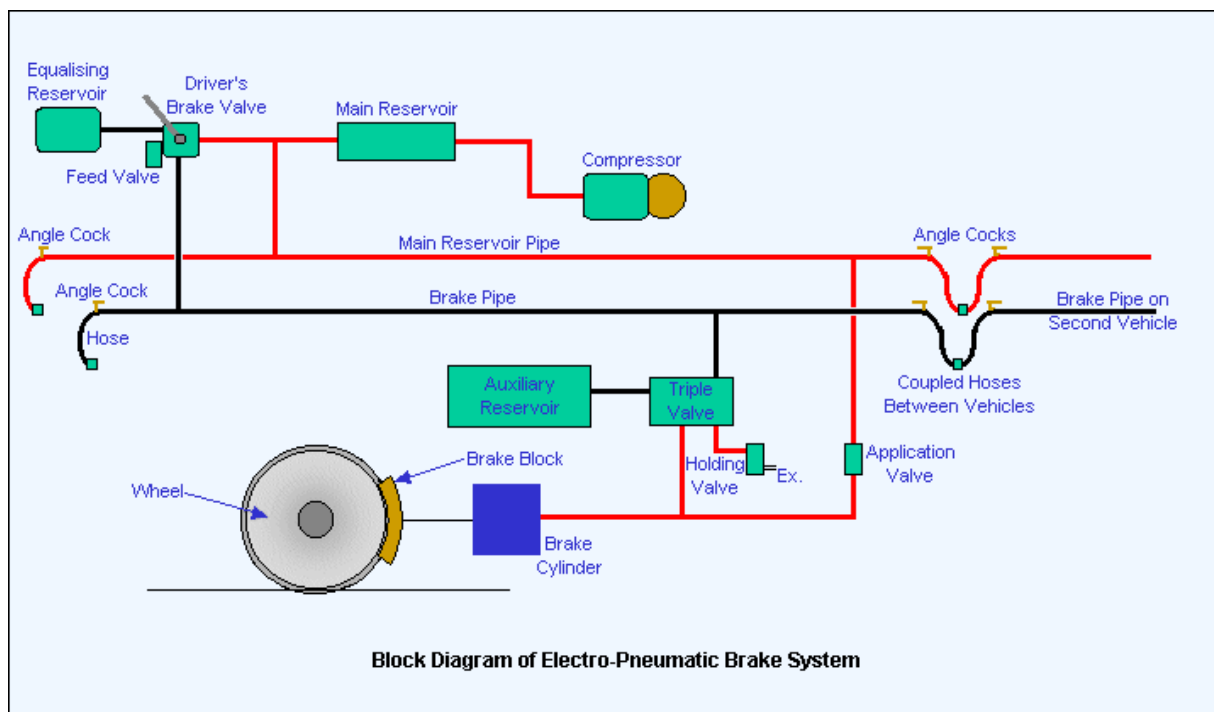

The diagram left shows the pneumatic layout of a simple e-p brake system. The special wiring required is shown in the e-p brake electrical diagram.

The standard air brake equipment is provided as the safety system for back-up purposes. A main reservoir pipe is provided along the length of the train so that a constant supply of air is available on all cars. A connection pipe is provided between the main reservoir and the brake cylinders on each car. An "application valve" in this connection pipe will open when required to allow main reservoir air into the brake cylinders. Because the brake pipe is fully charged during an e-p application, the triple valve is in the release position so the brake cylinder is connected to the exhaust. For e-p operation, a "holding

valve" is added to the triple valve exhaust. When an e-p application is called for, the holding valve closes and prevents brake cylinder air escaping through the exhaust.

2.9.5. E-P Application

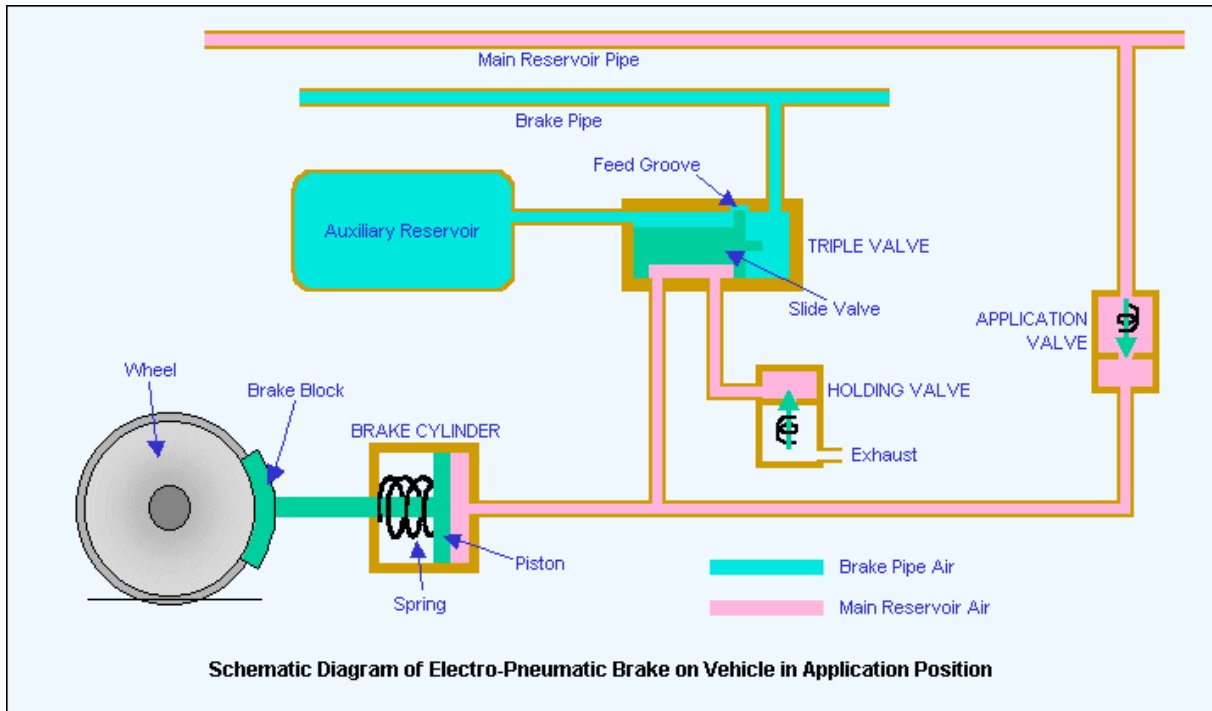

This diagram shows the operation of the holding and application valves during an e-p brake application.

The application valve is energised and open while the holding valve works the opposite way, being energised and closed. Main reservoir air feeds through the application valve into the brake cylinder to apply the brakes in the usual way.

2.9.6. Brake Cylinder Pressure

It is essential to ensure that, during braking, the train wheels do not skid. Skidding reduces the braking capability and it damages wheels and rails. Wheels involved in a skid will often develop "flats", a small flat patch on the tyre which can normally only be removed by reprofiling the wheel in a workshop. To reduce the risk of skidding, brake cylinder pressure must be restricted. In a pure air brake system, a natural restriction is imposed by the maximum allowed brake pipe pressure and in the proportion of volume between the auxiliary reservoir and the brake cylinder. In an e-p equipped train, the main reservoir supply is not restricted, so it would be possible to go on pumping air into the brake cylinder until it burst. Of course, this will not happen because the brake cylinder is fitted with a safety valve (not shown in the diagram) set at the maximum pressure normally obtained in full braking.

2.9.7. E-P Brake Release

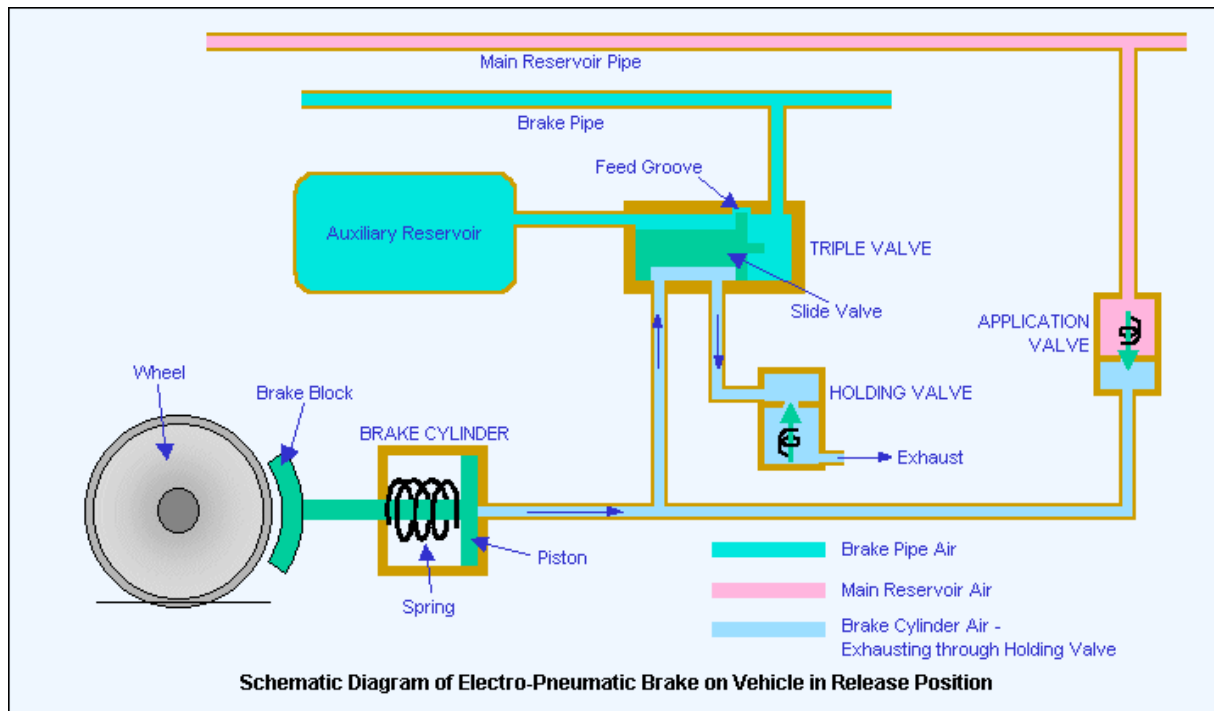

In the "Release" position (diagram left), both electrically operated valves are de-energised, the application valve being closed and the holding valve being open. Once the holding valve is open, brake cylinder air can escape and release the brakes. It is possible to stop the release by energising the holding valve again. This prevents any more brake cylinder air escaping. By adjusting the applications and releases of the brake during the stop, the driver is able to get a very precise stopping position. In addition, the response of the equipment to his commands is instantaneous on every car. This sort of control is essential for a rapid transit service on a metro line with frequent stops, heavy patronage and short headways.

2.9.8. E-P Control

Electro-Pneumatic brakes are controlled by the driver's brake valve handle. It is usually the same handle used to control the air brake. Electrical contacts are provided so that selection of a position will energise the train wires required to operate the e-p valves on each car, as shown left.

Current to operate the brake control is supplied from a battery through a control switch, which is closed in the operative cab. In the release position, all contacts are open and the e-p valves on each car are de-energised. In the "Application" position, the holding and application contacts are energised and the holding and application valves will be energised on each car to cause the brakes to apply. Note that the contact for the holding

wire is arranged to close first so that no air will escape when the application valve is opened.

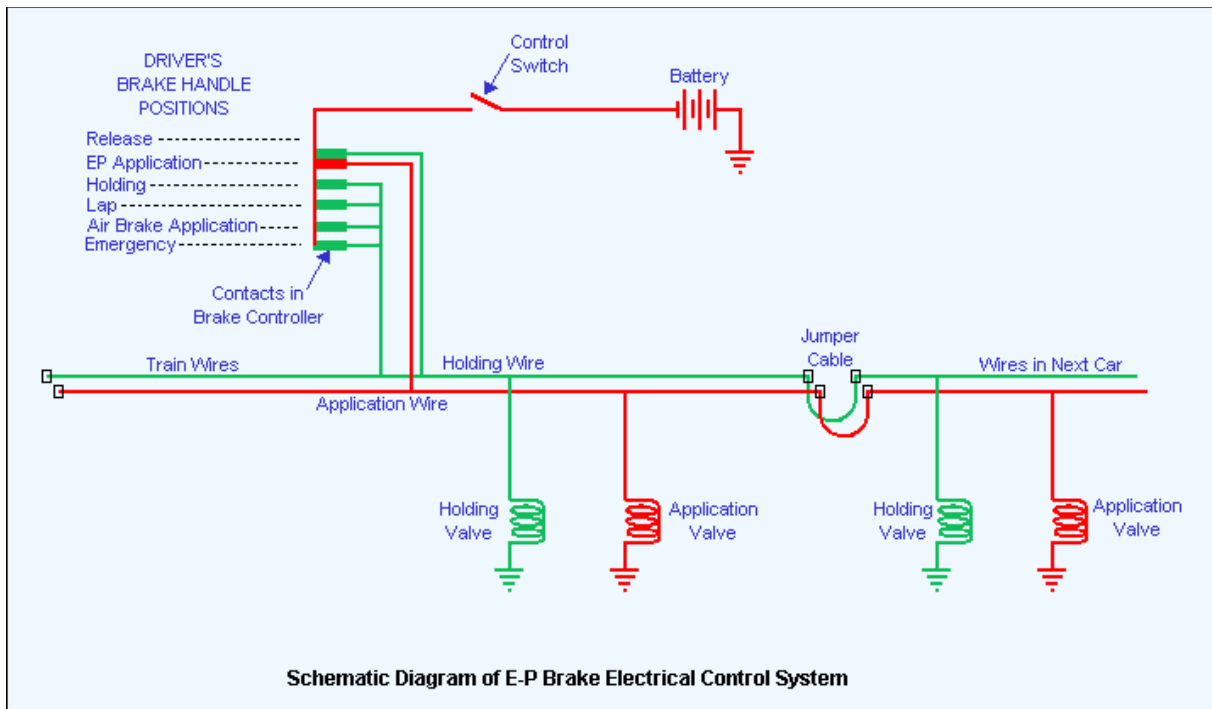

In the "Holding" position, only the holding wire is energised. If this position is selected after an application, the brake cylinder pressure remains at the value reached at that time. If after a partial release, the brake cylinder pressure will remain at the lower value achieved at that time. In effect, the driver can add or subtract air at will and can obtain an infinite variety of braking rates according to the requirements of each stop.

In all other positions, only the holding wire is energised. In reality, it is not needed to allow the operation of the air brake but it is closed anyway to act as a back up.

2.9.9. E-P Variations

There have been a number of developments of the e-p braking system over the years, including a common addition the "Self Lapping" brake. There have also been "retardation controllers" and, more recently, variable load control and single wire or P-wire control.

2.9.10. Self Lapping Brakes

A "self lapping" brake is really a brake controller (brake stand or brake valve, call it what you will) in the driver's cab, where the position of the brake handle between "Release" and "Application" corresponds to the brake rate achieved by the equipment in theory at least. This is similar in principle to the self lapping controllers fitted to some air braked locomotives. A number of different systems have been adopted, including one which uses a pressure sensitive valve detecting brake cylinder pressure and comparing it with the

position of the brake handle. When the pressure corresponds to the position of the brake handle, the application electrical connection is opened to keep the brake cylinder pressure at that level.

Another version was developed, using a mercury filled tube inside the brake controller. The mercury was used to conduct the control current to the application and holding wires. The shape of the tube was oval and it was aligned "forward and aft" so it allowed the mercury to flow forward if the train started braking. When "Application" was called for, the movement of the brake handle towards full application tilted the mercury tube backwards and caused the holding and application valves to be energised. As the train brakes applied, the mercury detected the slowing of the train and it ran forward in the tube. This had the effect of cutting off the application so that the rate of braking conformed to the angle of the tube set by the driver's movement of his brake handle.

2.9.11. Retardation Controller

The mercury brake controller was an adaption of a device introduced to London Underground in the mid-1930s called the "mercury retarder" or "retardation controller".

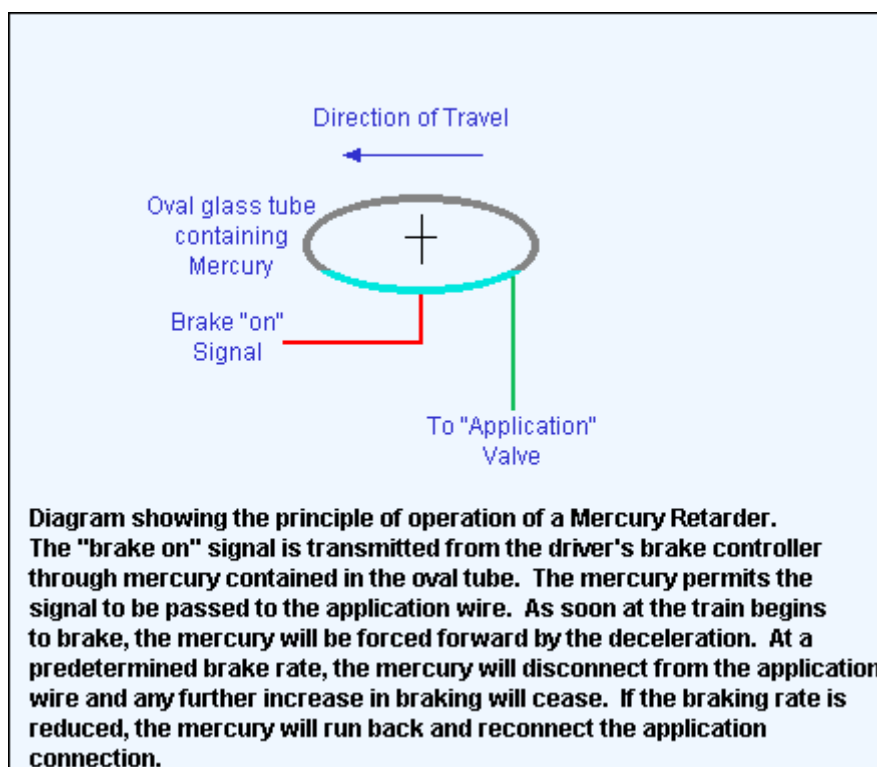

The mercury retarder is a dynamic switch set into the e.p. brake application circuit, comprising a glass tube filled with mercury. It is mounted parallel to the motion of the train so that the mercury fluid reacts to the train's braking. The tube is curved so that

the electrical contact at the base is always covered with mercury but a second contact, set higher up the rear of the tube, becomes exposed when the mercury runs forward during braking. It has the effect of measuring the deceleration rate. It cuts off application at a pre set level, no matter how much more the driver tries to put into the brake cylinders. Its main purpose was to reduce flatted wheels. It also acted as a crude form of load compensation.

In the London Underground version, two retarders were provided and they were stationary, being fixed in the driving car. They were used to regulate the rate of braking at the full application end of the range, primarily to reduce skidding and the dreaded "flats" on wheels. One retarder limited the application while the second was used to reduce the brake cylinder pressure by releasing some air through a special "blow down" valve.

Retardation controllers were later used to control braking rates on the world's first ATO railway, the Victoria Line. Four were used in all, each being set at a different angle and selected as necessary to give the required braking rate. They were also used by British Rail as self-lapping brake controllers provided on the EMU stocks built in the 1960s and 70s.

2.9.12. Variable Load Control

Although the retardation controller is a form of load control - because the braking rate is monitored, a heavier train will require more brake cylinder pressure, so the retarder will not reach its setting until the right rate is reached - it is rather crude. It only monitors the whole train, not individual cars. This means that lightly loaded cars in a generally heavy train are still at risk from a skid or wheelslide, as it is called. The solution is in variable load control. The car weight is monitored, usually by a lever fitted between the car and the bogie, which detects the bogie spring depression as weight increases. The lever is connected to a regulating valve in the brake cylinder feed pipe, so that the brake cylinder pressure is varied in relation to the weight of the car. With the introduction of air suspension, load control is achieved by monitoring the level of air in the suspension system and regulating brake cylinder pressure accordingly. Nowadays, the same load signals are used to vary acceleration and dynamic braking according to car weight.

2.9.13. P-Wire Control

As train control systems grew more complicated, more train wires were required and the traditional 10-wire jumper used by so many railways grew to the 40-wire jumper often seen today. In an attempt to reduce wiring, a novel form of e-p brake control appeared in the 1970s called the P-wire system. The brake rate was controlled by a single wire carrying pulses of different lengths to correspond to different brake rates. The pulse width was modulated to correspond to the brake demand required and it became known as the PWM (Pulse Width Modulation) system or P-wire, for short. The system was "fail-safe" in that no pulse activated the full brake while a continuous pulse kept the brake released.

2.9.14. PBL90 System

No survey of the electro-pneumatic brake would be complete without a reference to the European system known as PBL90. This is not a pure e-p brake system as used on metros and suburban systems but more of an electrically assisted air brake control system. It is designed to allow vehicles with no electro-pneumatic brake controls to operate in a train with e-p control available on the locomotive or power car.

2.10. VACUUM BRAKES

2.10.1. Introduction

The vacuum brake was, for many years, used in place of the air brake as the standard, fail-safe, train brake on railways in the UK and countries whose railway systems were based on UK practice. Here is a simplified description of the vacuum system.

2.10.2. Basics

A moving train contains energy, known as kinetic energy, which needs to be removed from the train in order to cause it to stop. The simplest way of doing this is to convert the energy into heat. The conversion is usually done by applying a contact material to the rotating wheels or to discs attached to the axles. The material creates friction and converts the kinetic energy into heat. The wheels slow down and eventually the train stops. The material used for braking is normally in the form of a block or pad.

The vast majority of the world's trains are equipped with braking systems which use compressed air as the force used to push blocks on to wheels or pads on to discs. These systems are known as "air brakes" or "pneumatic brakes". The compressed air is transmitted along the train through a "brake pipe". Changing the level of air pressure in the pipe causes a change in the state of the brake on each vehicle. It can apply the brake, release it or hold it "on" after a partial application. The system is in widespread use throughout the world. For more information, see [Air Brakes](#).

An alternative to the air brake, known as the vacuum brake, was introduced around the early 1870s, the same time as the air brake. Like the air brake, the vacuum brake system is controlled through a brake pipe connecting a brake valve in the driver's cab with braking equipment on every vehicle. The operation of the brake equipment on each vehicle depends on the condition of a vacuum created in the pipe by an ejector or exhauster. The ejector, using steam on a steam locomotive, or an exhauster, using electric power on other types of train, removes atmospheric pressure from the brake pipe to create the vacuum. With a full vacuum, the brake is released. With no vacuum, i.e. normal atmospheric pressure in the brake pipe, the brake is fully applied.

The pressure in the atmosphere is defined as 1 bar or about 14.5 lbs. per square inch. Reducing atmospheric pressure to 0 lbs. per square inch, creates a near perfect vacuum which is measured as 30 inches of mercury, written as 30 Hg. Each 2 inches of vacuum therefore represents about 1 lb. per square inch of atmospheric pressure.

In the UK, vacuum brakes operated with the brake pipe at 21 Hg, except on the Great Western Railway which operated at 25 Hg.

The vacuum in the brake pipe is created and maintained by a motor-driven exhauster. The exhauster has two speeds, high speed and low speed. The high speed is switched in to create a vacuum and thus release the brakes. The slow speed is used to keep the vacuum at the required level to maintain brake release. It maintains the vacuum against small leaks in the brake pipe. The vacuum in the brake pipe is prevented from exceeding its nominated level (normally 21 Hg) by a relief valve, which opens at the setting and lets air into the brake pipe to prevent further increase.

2.10.3. Principal Parts of the Vacuum Brake System

This diagram shows the principal parts of the vacuum brake system as applied to an electric or diesel train. The systems used on steam locomotives were somewhat different.

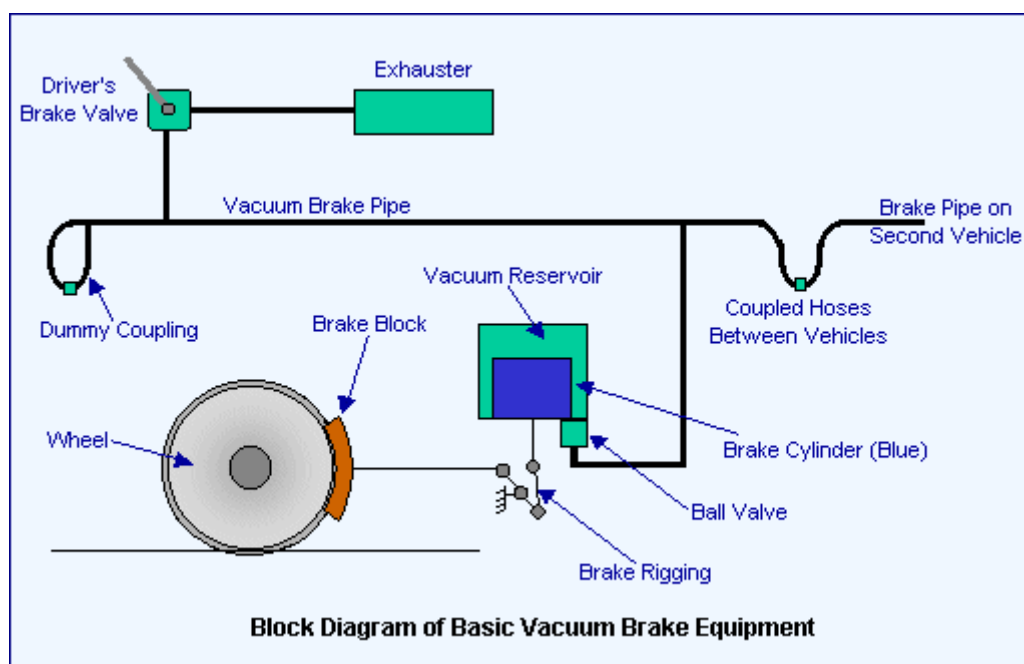

a-Driver's Brake Valve

The means by which the driver controls the brake. The brake valve will have (at least) the following positions: "Release", "Running", "Lap" and "Brake On". There may also be a "Neutral" or "Shut Down" position, which locks the valve out of use. The "Release" position connects the exhauster to the brake pipe and switches the exhauster to full speed. This raises the vacuum in the brake pipe as quickly as possible to get a release.

In the "Running" position, the exhauster keeps running but at its slow speed. This ensures that the vacuum is maintained against any small leaks or losses in the brake pipe, connections and hoses.

"Lap" is used to shut off the connection between the exhauster and the brake pipe to close off the connection to atmosphere after a brake application has been made. It can

be used to provide a partial release as well as a partial application, something not possible with the original forms of air brake.

"Brake On" closes off the connection to the exhauster and opens the brake pipe to atmosphere. The vacuum is reduced as air rushes in.

Some brake valves were fitted with an "Emergency" position. Its operation was the same as the "Brake On" position, except that the opening to atmosphere was larger to give a quicker application.

b-Exhauster

A two-speed rotary machine fitted to a train to evacuate the atmospheric pressure from the brake pipe, reservoirs and brake cylinders to effect a brake release. It is usually controlled from the driver's brake valve, being switched in at full speed to get a brake release or at slow speed to maintain the vacuum at its release level whilst the train is running. Exhausters are normally driven off an electric motor but they can be run directly from a diesel engine.

c-Brake Pipe

The vacuum-carrying pipe running the length of the train, which transmits the variations in pressure required to control the brake. It is connected between vehicles by flexible hoses, which can be uncoupled to allow vehicles to be separated. The use of the vacuum system makes the brake "fail safe", i.e. the loss of vacuum in the brake pipe will cause the brake to apply.

d-Dummy Coupling

At the ends of each vehicle, a dummy coupling point is provided to allow the ends of the brake pipe hoses to be sealed when the vehicle is uncoupled. The sealed dummy couplings prevent the vacuum being lost from the brake pipe.

e-Coupled Hoses

The brake pipe is carried between adjacent vehicles through flexible hoses. The hoses can be sealed at the outer ends of the train by connecting them to dummy couplings.

f- Brake Cylinder (shown in blue)

Each vehicle has at least one brake cylinder. Sometimes two or more are provided. The movement of the piston contained inside the cylinder operates the brakes through links called "rigging". The rigging applies the blocks to the wheels. I do not know of a vacuum

brake system which uses disc brakes. The piston inside the brake cylinder moves in accordance with the change in vacuum pressure in the brake pipe. Loss of vacuum applies the brakes, restoration of the vacuum releases the brakes.

g-Vacuum Reservoir

The operation of the vacuum brake relies on the difference in pressure between one side of the brake cylinder piston and the other. In order to ensure there is always a source of vacuum available to operate the brake, a vacuum reservoir is provided on, or connected to the upper side of the piston. In the simplest version of the brake, shown above, the brake cylinder is integral with the vacuum reservoir. Some versions of the brake have a separate reservoir and a piped connection to the upper side of the piston.

h-Brake Block

This is the friction material which is pressed against the surface of the wheel tread by the upward movement of the brake cylinder piston. Often made of cast iron or some composition material, brake blocks are the main source of wear in the brake system and require regular inspection to see that they are changed when required.

I-Brake Rigging

This is the system by which the movement of the brake cylinder piston transmits pressure to the brake blocks on each wheel. Rigging can often be complex, especially under a passenger car with two blocks to each wheel, making a total of sixteen. Rigging requires careful adjustment to ensure all the blocks operated from one cylinder provide an even rate of application to each wheel. If you change one block, you have to check and adjust all the blocks on that axle.

j-Ball Valve

The ball valve is needed to ensure that the vacuum in the vacuum reservoir is maintained at the required level, i.e. the same as the brake pipe, during brake release but that the connection to the brake pipe is closed during a brake application. It is necessary to close the connection as soon as the brake pipe vacuum is reduced so that a difference in pressure is created between the upper and lower sides of the brake cylinder piston. See the next paragraph Operation on Each Vehicle.

2.10.4.Operation on Each Vehicle

a-Brake Release

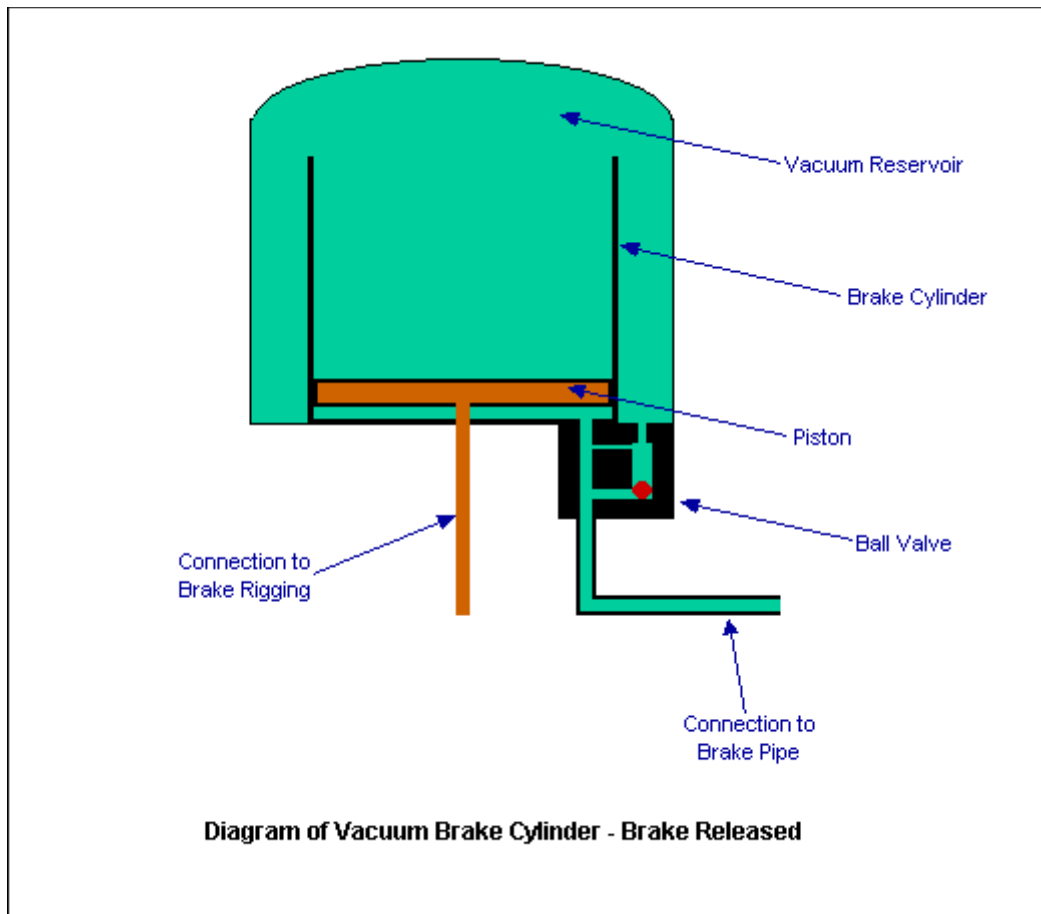

This diagram shows the condition of the brake cylinder, ball valve and vacuum reservoir in the release position. The piston is at the bottom of the brake cylinder. Note how the brake cylinder is open at the top so that it is in direct connection with the vacuum reservoir.

A vacuum has been created in the brake pipe, the vacuum reservoir and underneath the piston in the brake cylinder. The removal of atmospheric pressure from the system has caused the ball valve to open the connection between the vacuum reservoir and the brake pipe. The fall of the piston to the bottom of the brake cylinder causes the brake blocks to be released from the wheels.

b-Brake Application

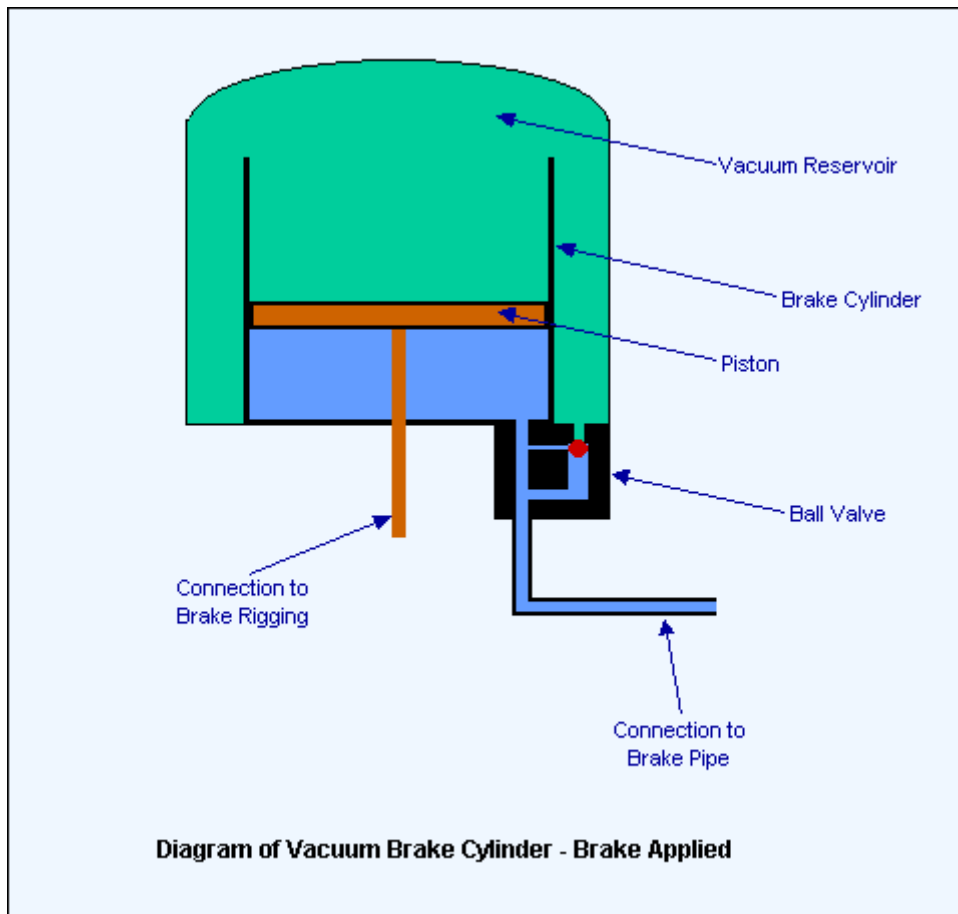

This diagram shows the condition of the brake cylinder, ball valve and vacuum reservoir in the application position. The vacuum has been reduced by the admission of atmospheric pressure into the brake pipe. This has forced the piston upwards in the brake cylinder. By way of the connection to the brake rigging, the upward movement of the piston has caused the brake blocks to be applied to the wheels.

The movement of the piston in the brake cylinder relies on the fact that there is a pressure difference between the underside of the piston and the upper side. During the brake application, the vacuum in the brake pipe is reduced by admitting air from the atmosphere. As the air enters the ball valve, it forces the ball (in red in the diagram above) upwards to close the connection to the vacuum reservoir. This ensures that the vacuum in the reservoir will not be reduced. At the same time, the air entering the underside of the brake cylinder creates an imbalance in the pressure compared with the pressure above the piston. This forces the piston upwards to apply the brakes.

2.10.5. Additional Features of the Vacuum Brake

a-Accelerators

The vacuum brake had one major advantage over the original air brake system. It could provide a partial release, which the air brake could not. However, it is slower in operation than the air brake, particularly over a long train. This eventually led to the adoption of accelerator valves, which helped to speed up the operation on each vehicle. The accelerator valve is fitted to each vehicle on the connection between the brake pipe and the brake cylinder. It detects the loss of vacuum when the pressure rises in the brake pipe and opens the pipe to atmosphere on the vehicle. This helps to reduce the vacuum more quickly on each vehicle and therefore increases the propagation rate along the brake pipe. In the more sophisticated versions fitted to EMUs accelerators valves were electrically operated by the movement of the driver's brake valve to the "brake on" position.

b-Two Pipe Systems

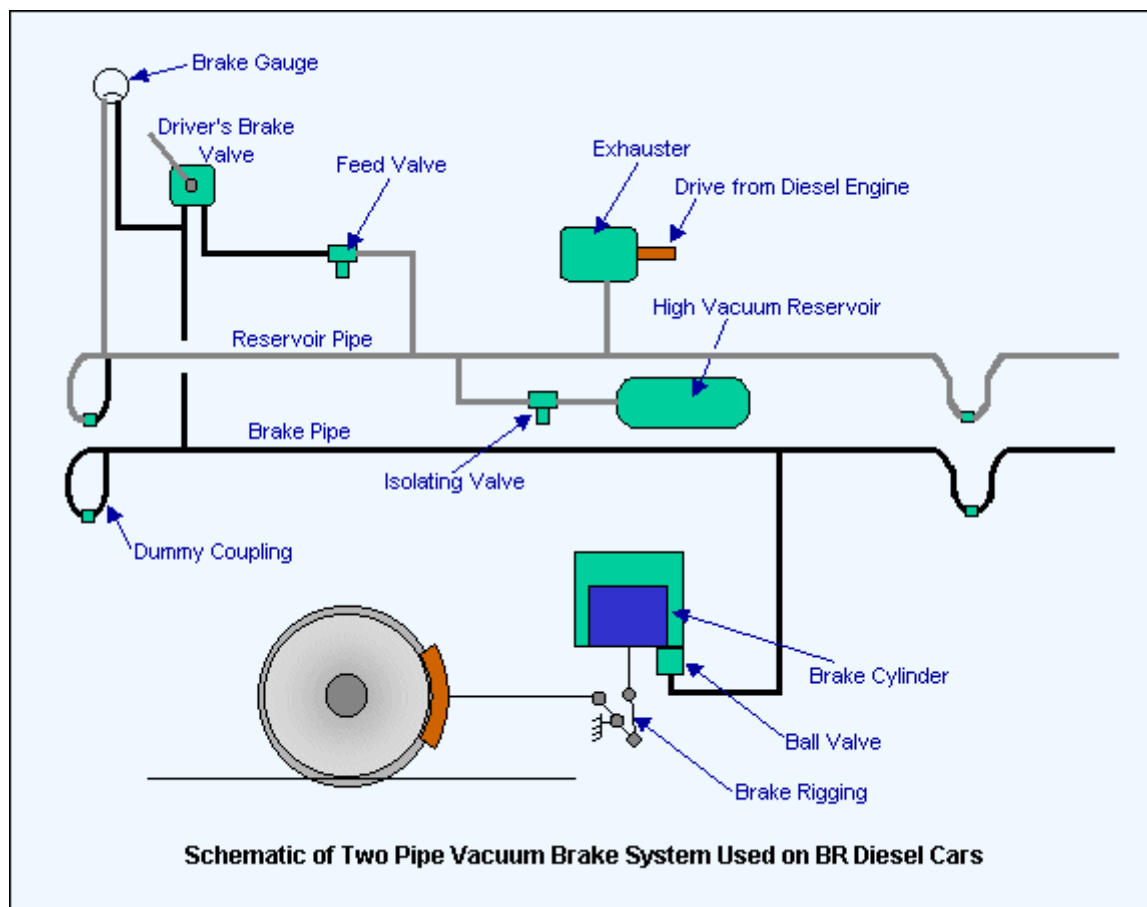

Another version of the vacuum brake used two train pipes. The usual brake pipe operated in the conventional way but the second pipe was provided to give an additional supply to speed up the brake release. The second pipe is called the reservoir pipe. The diagram below shows a schematic of the system, with the reservoir pipe shown in grey.

The two-pipe system was introduced on diesel railcars where the exhauster was driven directly off the diesel engine. Since the engine was only idling if the train was stationary, the exhauster would only be running at slow speed. This meant that the restoration of the vacuum in the brake pipe and cylinders along the train would be very slow. To get a rapid brake release when it was needed to start the train therefore, a "high vacuum" reservoir was provided on each car, the reservoirs being supplied from a second train pipe called the Reservoir Pipe. These additional reservoirs were characterised by their operating vacuum of 28 Hg, as opposed to the 21 Hg used in the brake pipe and brake cylinders.

While the train is moving and the driver's brake valve is in the "Running" position, the exhauster is connected to the reservoir pipe and through the driver's brake valve to the brake pipe. An automatic feed valve fitted between the reservoir pipe and the driver's brake valve limits the maximum vacuum passing to the driver's brake valve at 21 Hg. This means that the vacuum in the brake pipe and brake cylinders will be limited to 21 Hg. However, the vacuum created by the exhauster in the reservoir and high vacuum reservoirs will reach 28 Hg, as shown in the diagram above in grey.

To apply the brake, "Brake On" is selected by the driver and the brake pipe is opened to atmosphere at his brake valve. The exhauster will continue to run and maintain the 28 Hg reservoir level. The connection to the feed valve is closed by the driver's brake valve when it is in the "Brake On" position. A partial application can be made by moving the handle to "Lap".

To get a release, the brake valve is moved to the "Running" position. There is no "Release" position. As soon as "Running" is selected, the connection to atmosphere is closed and the connection to the feed valve and exhauster opens to start restoring the vacuum. As there is a store of "high" vacuum available in the reservoir pipe and reservoirs, the process is speeded up to give a rapid release.

Each reservoir has an automatic isolating valve between itself and the brake pipe. This valve is set to 19 Hg and closes if the vacuum in the reservoir falls below this level. This has the effect of preventing the reservoir from being emptied. The volume of the reservoir is such that it can restore the vacuum for several applications and releases before it drops below 19 Hg.

c-Equalising Reservoir

A problem with both air and vacuum brakes is that the driver's brake valve is at one end of a long pipe. If a partial application is required on a long train, a good deal of skill is required to estimate how much air to let in (or let out on an air braked train) to get the application wanted. To help set the brake to the right level, some vacuum brake systems have an equalising reservoir. This is fitted between the driver's brake valve and the brake pipe and it acts in conjunction with a relay valve or "air admission valve". When the driver moves the brake valve to the "Brake On" position, air is admitted into the equalising reservoir, not directly into the brake pipe. He monitors the lowering of the vacuum using the gauge provided in the cab. The reduction of vacuum causes the air admission valve to open the brake pipe to atmosphere. When the vacuum level in the brake pipe has fallen to the level set in the equalising reservoir, the air admission valve closes to maintain the brake pipe vacuum at that level.

The main advantage of the equalising system is that it allows the driver to select a level of brake quickly, using the small volume of the equalising reservoir instead of having to wait for the level along a whole train's length of brake pipe to settle before he knows what the real level is.

2.10.6. Other Vacuum Operated Equipment

On an air braked train, the compressed air supply is used to provide power for certain other functions besides braking. These include door operation, whistles, traction equipment, pantograph operation and sanders. Some of these devices on vacuum fitted trains are operated using the vacuum supply. Some electric trains with vacuum brakes have been fitted with vacuum operated pantographs, warning horns and rail sanders.

2.10.7. Vacuum Brakes on Steam Locomotives

So far, we have concentrated on the vacuum brake equipment provided for electric and diesel operated vehicles but by far the largest number of trains fitted with vacuum brakes were steam hauled. The principle of operation was the same as for other types of train but there were some differences as described below.

Ejectors

For some reason, exhausters are called ejectors on steam locomotives. They are, of course, steam operated. The ejector consists of a series of cones inside a tube. Steam is allowed to pass through the cones so that a vacuum is created in the tube and thus in the brake pipe to which it is connected. There are always two ejectors, large and small, which provide the brake release and vacuum maintenance functions respectively. The large ejector provides the rapid build-up of vacuum required for brake release and the

small ejector provides the constant vacuum needed to keep the brake pipe and cylinder vacuum at the correct level to maintain brake release.

On some locomotives, ejectors were combined with the driver's brake valve. Most had only "Brake On", "Running" and "Brake Off" positions and many were combined with a steam brake fitted to the locomotive and tender. The more sophisticated allowed a single brake application to apply the brakes on the train before they were applied on the locomotive. This gave a smooth and even stop and prevented "bunching" of coaches behind the locomotive. Drivers were taught that it was best to slow the train down and then gently ease off the brakes as the train came to a stop. This required them to restore much of the vacuum by the time the train was brought to a stand, allowing a quick release without having to run the large ejector for very long, thereby saving steam.

2.10.8. Comment

The vacuum brake was not widely popular outside the UK and UK inspired railways, but it has the advantage of being simple in design and of having the ability to get a partial release, something the air brake could not do without additional equipment. The vacuum brake was not as effective as the air brake, it taking longer to apply and requiring large cylinders to provide the same brake effort as the air brake. It was also slow to release and requires additional equipment to speed up its operation.

2.11. PASSENGER COACH PARTS

A diagram showing the standard names used in the UK for passenger coach parts.

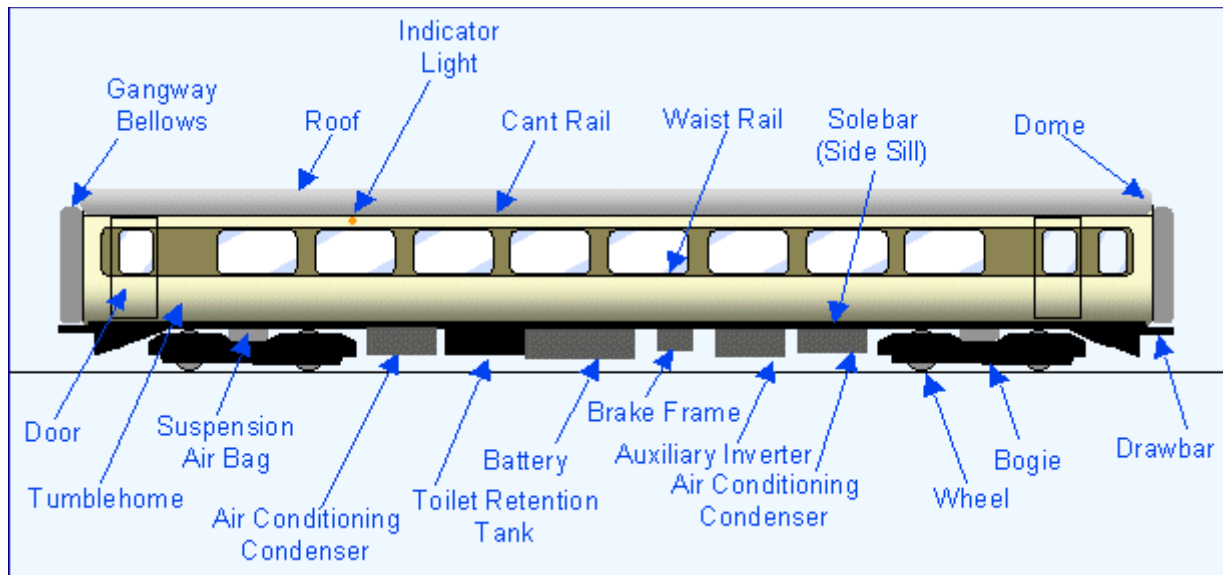

Notes:

1. The Dome is the three dimensional part which forms the end of the roof where it meets the body end.
2. Tumblehome is the inward curve of the lower body panel as it falls towards the solebar.
3. In the US, there are various alternative names applied to these parts.
4. The air conditioning units are usually split so that the heavy compressor and associated pumps are under the floor and the distribution fans are mounted in the vehicle roof.

2.12. ELECTRONIC POWER FOR TRAINS

2.12.1. Introduction

This page describes the most recent developments of electric train power equipment including the latest IGBT controlled 3-phase Alternating Current (AC) motors and the new permanent magnet motor.

2.12.2. AC and DC Differences

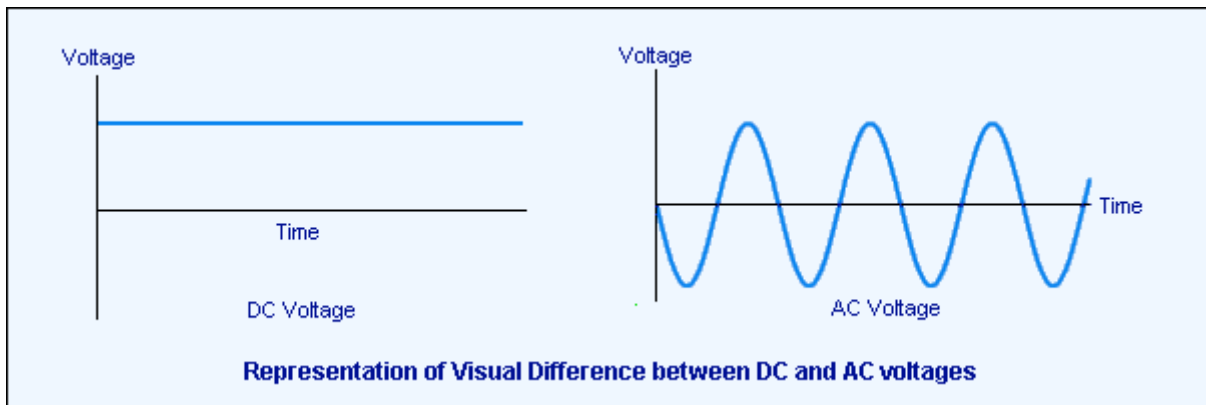

To understand the principles of modern traction power control systems, it is worth a look at the basics of DC and AC circuitry. DC is direct current - it travels in one direction only along a conductor. AC is alternating current so called because it changes direction, flowing first one way along the conductor, then the other. It does this very rapidly. The number of times it changes direction per second is called the frequency and is measured in Hertz (Hz). It used to be called cycles per second, in case you've read of this in historical papers. In a diagrammatic representation, the two types of current appear as shown in the diagram above left.

From a transmission point of view, AC is better than DC because it can be distributed at high voltages over a small size conductor wire, whereas DC needs a large, heavy wire or, on many DC railways, an extra rail. DC also needs more frequent feeder substations than AC the ratio for a railway averages at about 8 to 1. It varies widely from one application to another but this gives a rough idea. See also [Electric Traction Pages Power Supplies](#).

Over the hundred years or so since the introduction of electric traction on railways, the rule has generally been that AC is used for longer distances and main lines and DC for shorter, suburban or metro lines. DC gets up to 3000 volts, while AC uses 15,000 - 50,000 volts.

Until recently, DC motors have been the preferred type for railways because their characteristics were just right for the job. They were easy to control too. For this reason, even trains powered from AC supplies were usually equipped with DC motors.

2.12.3. AC Locomotives with DC Drives

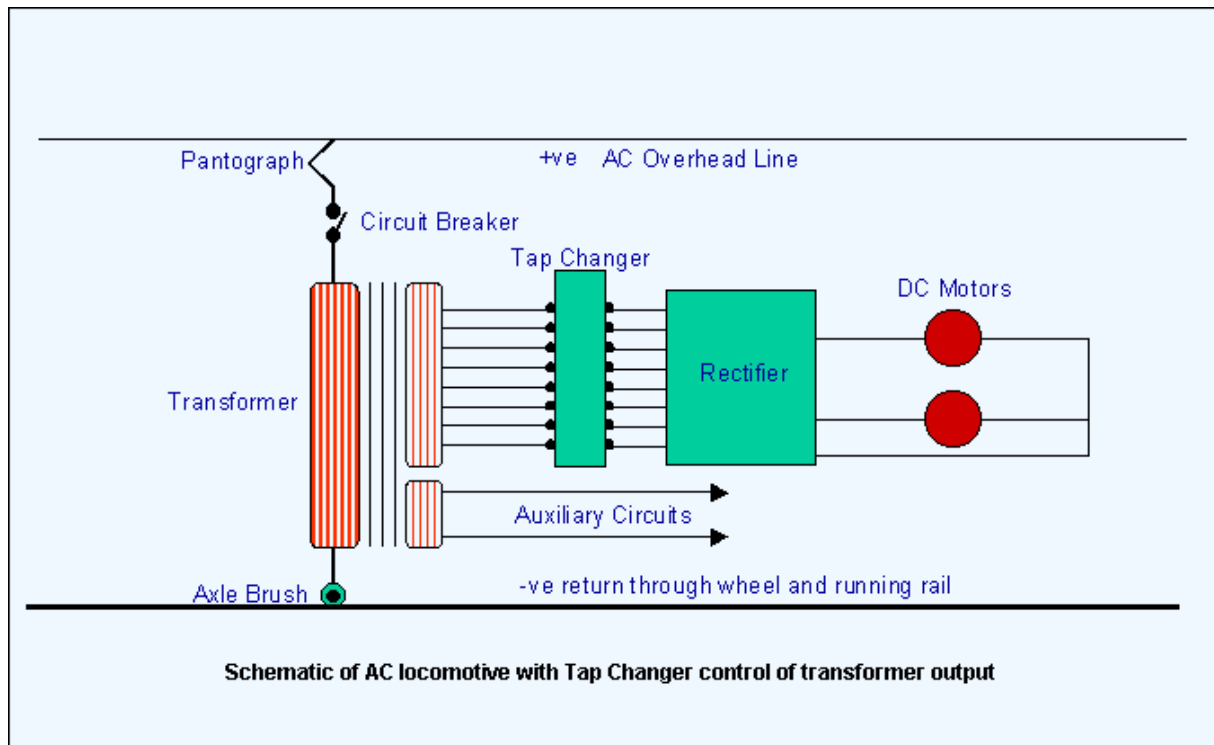

This diagram (above) shows a simplified schematic for a 25 kV AC electric locomotive used in the UK from the late 1960s. The 25 kV AC is collected by the pantograph and passed to the transformer. The transformer is needed to step down the voltage to a level which can be managed by the traction motors. The level of current applied to the motors is controlled by a "tap changer", which switches in more sections of the transformer to increase the voltage passing through to the motors. It works in the same way as the [resistance controllers](#) used in DC traction, where the resistance contactors are controlled by a camshaft operating under the driver's commands.

Before being passed to the motors, the AC has to be changed to DC by passing it through a rectifier. For the last 30 years, rectifiers have used diodes and their derivatives, the continuing development of which has led to the present, state-of-the-art AC traction systems.

2.12.4. The Diode

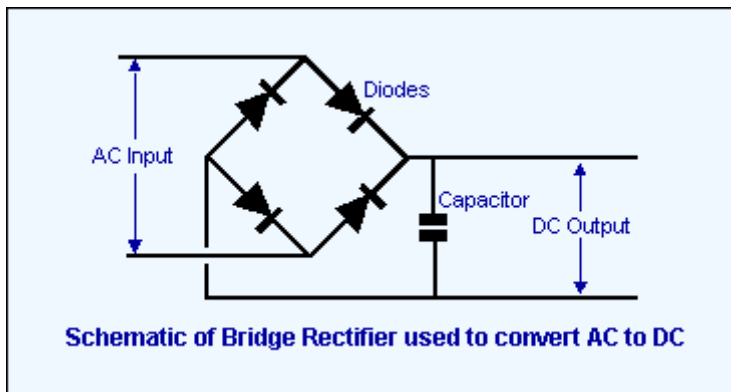

A diode is a device with no moving parts, known as a semi-conductor, which allows current to flow through it in one direction only. It will block any current which tries to flow in the opposite direction. Four diodes arranged in a bridge configuration, as shown below, use this property to convert AC into DC or to "rectify" it. It is called a "bridge rectifier". Diodes quickly became popular for railway applications because they represent a low maintenance option. They first appeared in the late 1960s when diode rectifiers were introduced on 25 kV AC electric locomotives.

2.12.5. The Thyristor

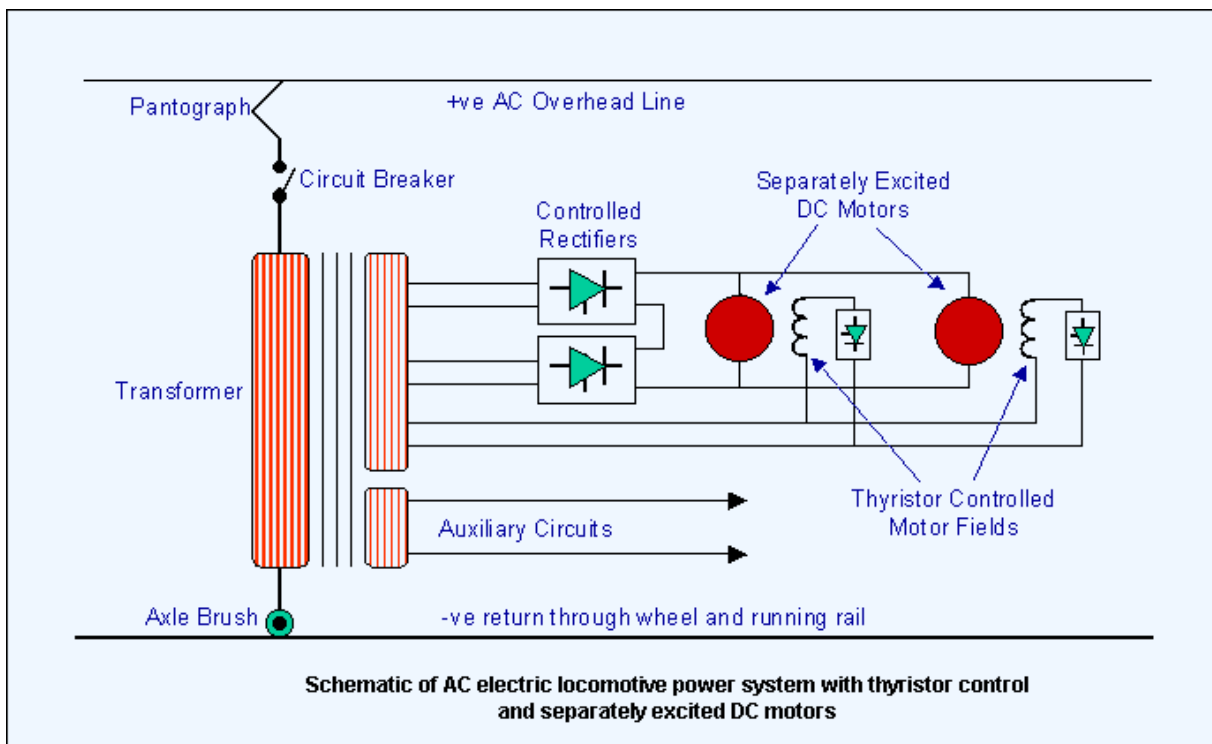

The thyristor is a development of the diode. It acts like a diode in that it allows current to flow in only one direction but differs from the diode in that it will only permit the current to flow after it has been switched on or "gated". Once it has been gated and the current

is flowing, the only way it can be turned off is to send current in the opposite direction. This cancels the original gating command. It's simple to achieve on an AC locomotive because the current switches its direction during each cycle. With this development, controllable rectifiers became possible and tap changers quickly became history. A thyristor controlled version of the 25 kV AC electric locomotive traction system looks like the diagram here on the left.

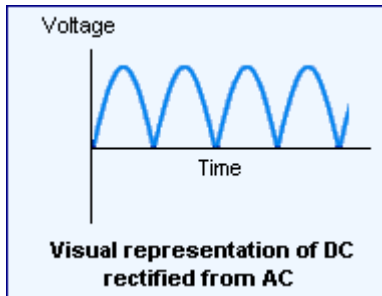

A tapping is taken off the transformer for each DC motor and each has its own controlling thyristors and diodes. The AC from the transformer is rectified to DC by chopping the cycles, so to speak, so that they appear in the raw as half cycles of AC as shown on the left.

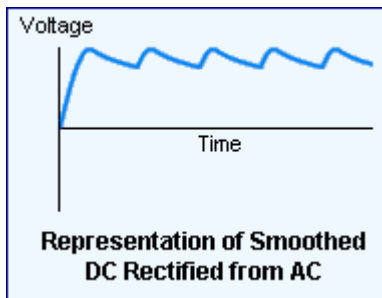

In reality, a smoothing circuit is added to remove most of the "ripple" and provide a more constant power flow as shown in the diagram (left). Meanwhile, the power level for the motor is controlled by varying the point in each rectified cycle at which the thyristors are fired. The later in the cycle the thyristor is gated, the lower the current available to the motor. As the gating is advanced, so the amount of current increases until the thyristors are "on" for the full cycle. This form of control is known as "phase angle control".

2.12.6. SEPEX

In more recent thyristor control systems, the motors themselves are wired differently from the old standard DC arrangement. The armatures and fields are no longer wired in series, they are wired separately separate excitement, or [SEPEX](#). Each field has its own thyristor, which is used to control the individual fields more precisely.

Since the motors are separately excited, the acceleration sequence is carried out in two stages. In the first stage, the armature is fed current by its thyristors until it reaches the full voltage. This might give about 25% of the locomotive's full speed. In the second stage, the field thyristors are used to weaken the field current, forcing the motor to speed up to compensate. This technique is known as [field weakening](#) and was already used in pre-electronic applications.

A big advantage of SEPEX is that wheel slip can be detected and corrected quickly, instead of the traditional method of either letting the wheels spin until the driver noticed or using a [wheel slip relay](#) to switch off the circuit and then restart it.

2.12.7. DC Choppers

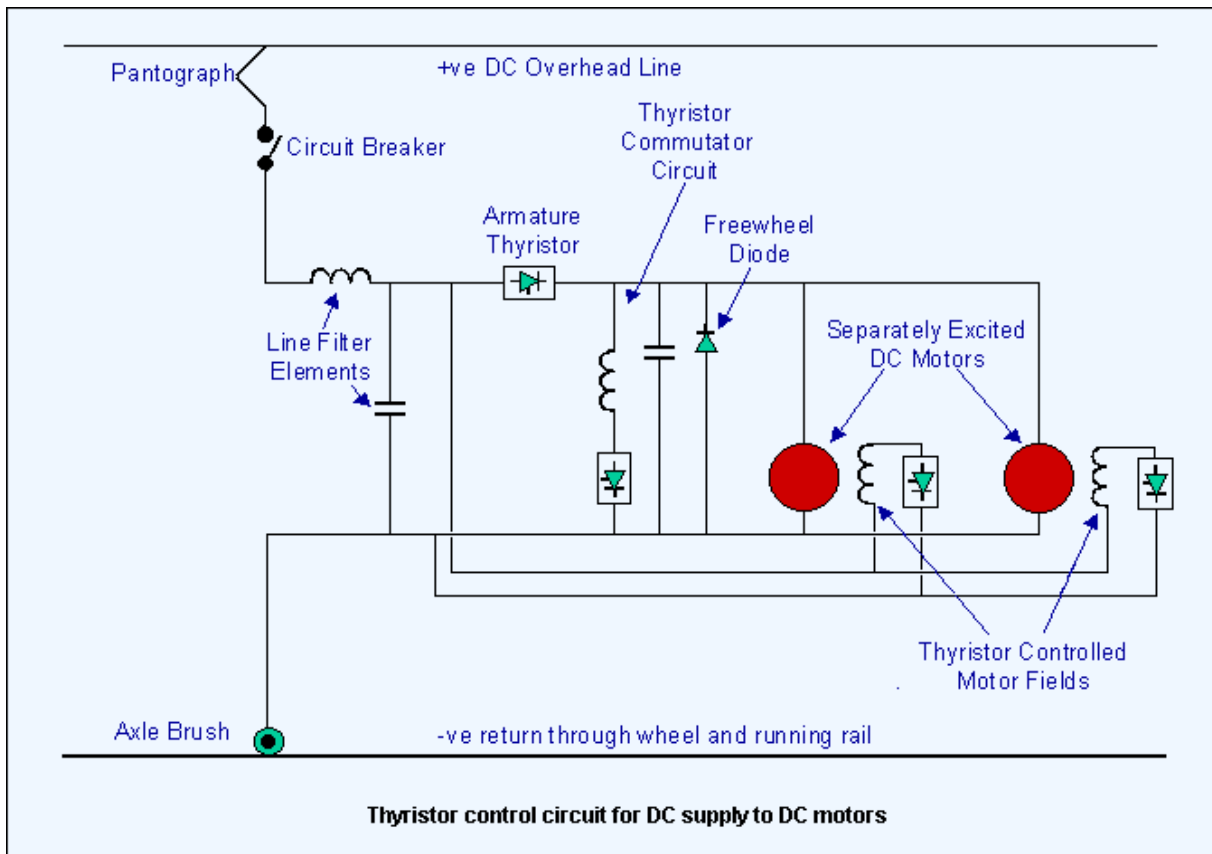

The traditional [resistance control of DC motors](#) wastes current because it is drawn from the line (overhead or third rail) and only some is used to accelerate the train to 20-25 mph when, at last, full voltage is applied. The remainder is consumed in the resistances. Immediately thyristors were shown to work for AC traction, everyone began looking for a way to use them on DC systems. The problem was how to switch the thyristor off once it had been fired, in other words, how to get the reverse voltage to operate on an essentially one-way DC circuit. It is done by adding a "resonant circuit" using an inductor and a capacitor to force current to flow in the opposite direction to normal. This has the effect of switching off the thyristor, or "commutating" it. It is shown as part of the complete DC thyristor control circuit diagram (left). It has its own thyristor to switch it on when required.

Two other features of the DC thyristor circuit are the "freewheel diode" and the "line filter". The freewheel diode keeps current circulating through the motor while the thyristor is off, using the motor's own electro magnetic inductance. Without the diode circuit, the current build up for the motor would be slower.

Thyristor control can create a lot of electrical interference with all that chopping, it's bound to. The "line filter" comprises a capacitor and an inductor and, as its name

suggests, it is used to prevent interference from the train's power circuit getting into the supply system.

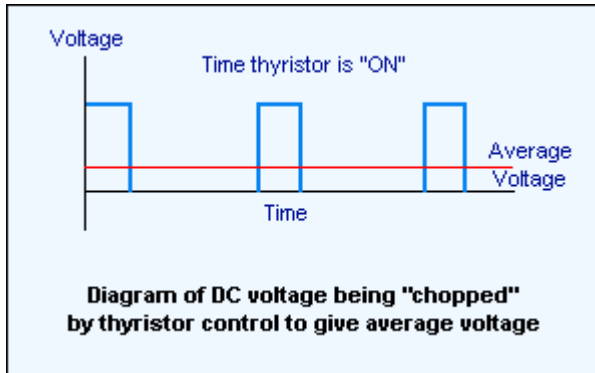

The thyristor in DC traction applications controls the current applied to the motor by chopping it into segments, small ones at the beginning of the acceleration process, gradually enlarging as speed increases. This chopping of the circuit gave rise to the nickname "chopper control". It is visually represented by the diagram below, where

the "ON" time of the thyristor is regulated to control the average voltage in the motor circuit. If the "ON" time is increased, so does the average voltage and the motor speeds up. The system began to appear on UK EMUs during the 1980s.

2.12.8. Dynamic Braking

Trains equipped with thyristor control can readily use dynamic braking, where the motors become generators and feed the resulting current into an on-board resistance (rheostatic braking) or back into the supply system (regenerative braking). The circuits are reconfigured, usually by a "motor/brake switch" operated by a command from the driver, to allow the thyristors to control the current flow as the motors slow down. An advantage of the thyristor control circuitry is its ability to choose either regenerative or rheostatic braking simply by automatically detecting the state of receptivity of the line. So, when the regenerated voltage across the supply connection filter circuit reaches a preset upper limit, a thyristor fires to divert the current to the on-board resistor.

2.12.9. The GTO Thyristor

By the late 1980s, the thyristor had been developed to a stage where it could be turned off by a control circuit as well as turned on by one. This was the "gate turn off" or GTO thyristor. This meant that the thyristor commutating circuit could be eliminated for DC fed power circuits, a saving on several electronic devices for each circuit. Now thyristors could be turned on and off virtually at will and now a single thyristor could be used to control a DC motor.

It is at this point that the conventional DC motor reached its ultimate state in the railway traction industry. Most systems now being built use AC motors.

2.12.10. AC Motors

There are two types of AC motor, synchronous and asynchronous. The synchronous motor has its field coils mounted on the drive shaft and the armature coils in the housing, the inverse of normal practice. The synchronous motor has been used in electric traction the most well-known application being by the French in their TGV Atlantique train. This used a 25 kV AC supply, rectified to DC and then inverted back to AC for supply to the motor. It was designed before the GTO thyristor had been sufficiently developed for railway use and it used simple thyristors. The advantage for the synchronous motor in this application is that the motor produces the reverse voltages needed to turn off the thyristors. It was a good solution in its day but it was quickly overtaken by the second type of AC motor the asynchronous motor when GTO thyristors became available.

2.12.11. The Asynchronous Motor

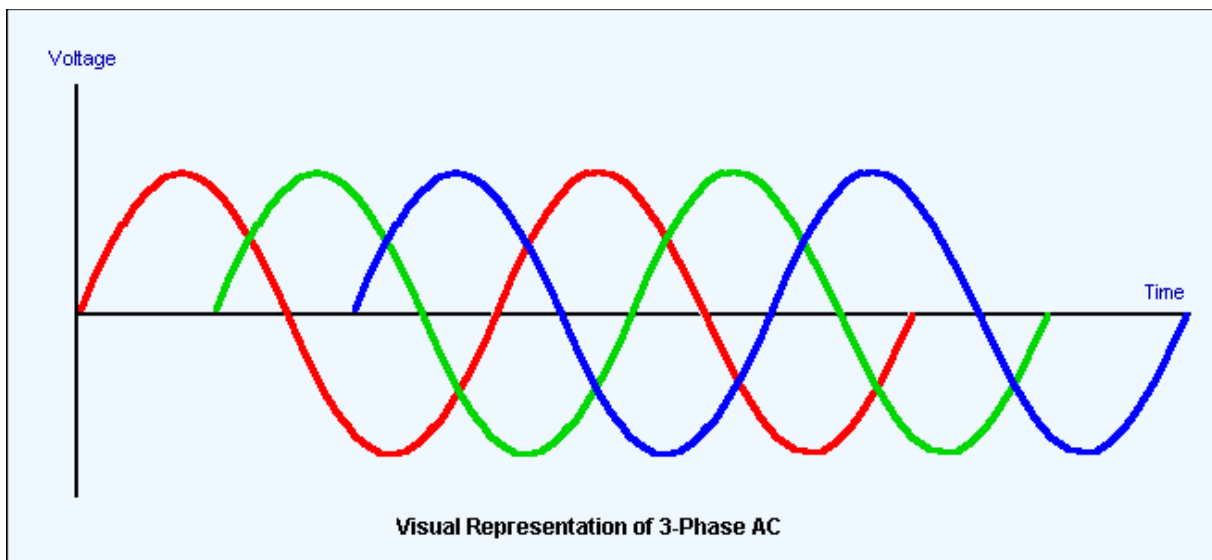

The asynchronous motor, also called the induction motor, is an AC motor which comprises a rotor and a stator like the DC motor, but the AC motor does not need current to flow through the armature. The current flowing in the field coils forces the rotor to turn. However, it does have to have a three phase supply, i.e. one where AC has three conductors, each conducting at a point one third into the normal cycle period, as visually represented in the diagram on the left.

The two big advantages of the 3-phase design are that, one, the motor has no brushes, since there is no electrical connection between the armature and the fields and, two, the armature can be made of steel laminations, instead of the large number of windings required in other motors. These features make it more robust and cheaper to build than a commutator motor.

2.12.12. AC Drive

Modern electronics has given us the AC drive. It has only become available with modern electronics because the speed of a 3-phase AC motor is determined by the frequency of its supply but, at the same time, the power has to be varied. The frequency used to be difficult to control and that is why, until the advent of modern electronics, AC motors were almost exclusively used in constant speed applications and were therefore unsuitable for railway operation. A modern railway 3-phase traction motor is controlled by feeding in three AC currents which interact to cause the machine to turn. The three phases are most easily provided by an inverter which supplies the three variable voltage, variable frequency (VVVF) motor inputs. The variations of the voltage and frequency are controlled electronically.

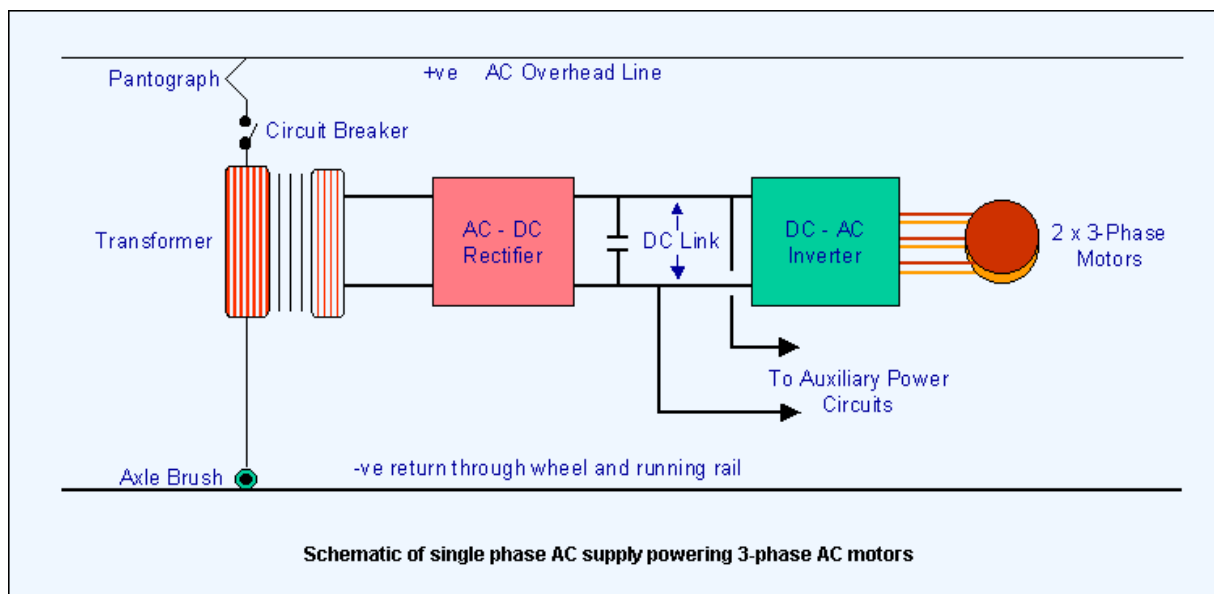

The AC motor can be used by either an AC or DC traction supply system. In the case of AC supply (diagram left), the line voltage (say 25kV single phase) is fed into a transformer and a secondary winding is taken off for the rectifier which produces a DC output of say 1500- 2000 volts depending on the application. This is then passed to the inverter which provides the controlled three phases to the traction motors. The connection between the rectifier and the inverter is called the DC link. This usually also supplies an output for the train's auxiliary circuits.

All the thyristors are GTOs, including those in the rectifier, since they are now used to provide a more efficient output than is possible with the older thyristors. In addition, all the facilities of DC motor control are available, including dynamic braking, but are provided more efficiently and with less moving parts. Applied to a DC traction supply, the 3-phase set-up is even more simple, since it doesn't need a transformer or a rectifier. The DC line voltage is applied to the inverter, which provides the 3-phase motor control.

Control of these systems is complex but it is all carried out by microprocessors. The control of the voltage pulses and the frequency has to be matched with the motor speed. The changes which occur during this process produce a set of characteristic buzzing noises which sound like the "gear changing" of a road vehicle and which can clearly be heard when riding on the motor car of an AC driven EMU.

2.12.13. IGBT

Having got AC drive using GTO thyristors universally accepted (well, almost) as the modern traction system to have, power electronics engineers have produced a new development. This is the IGBT or Insulated Gate Bipolar Transistor. The transistor was the forerunner of modern electronics, (remember transistor radios?) and it could be turned on or off like a thyristor but it doesn't need the high currents of the thyristor turn off. However it was, until very recently, only capable of handling very small currents measured in thousandths of amps. Now, the modern device, in the form of the IGBT, can handle thousands of amps and it has appeared in traction applications. A lower current version was first used instead of thyristors in auxiliary supply inverters in the early 1990s but a higher rated version has now entered service in the most recent AC traction drives. Its principle benefit is that it can switch a lot faster (three to four times faster) than GTOs. This reduces the current required and therefore the heat generated, giving smaller and lighter units. The faster switching also reduces the complex "gearing" of GTOs and makes for a much smoother and more even sounding acceleration buzz from under the train. With IGBTs, "gear changing" has gone.

2.12.14. Permanent Magnet Motor

The next development in electric motor design is the permanent magnet motor. This is a 3-phase AC asynchronous motor with the usual squirrel cage construction replaced by magnets fixed in the rotor. The motor requires a complex control system system but it can be up to 25% smaller than a conventional 3-phase motor for the same power rating. The design also gives lower operating temperatures so that rotor cooling isn't needed and the stator is a sealed unit with integral liquid cooling. By 2011, a number of different types of trains had been equipped with permanent magnet motors, including 25 AGV high speed train sets, trams in France and Prague and EMUs in Europe and Japan. The reduced size is particularly attractive for low floor vehicles where hub motors can be an effective way of providing traction in a compact bogie. Development of motor design and the associated control systems continues and it is certain that the permanent magnet motor will be seen on more railways in the future. A good description of the motor by Stuart Hillmansen, Felix Schmid and Thomas Schmid is in Railway Gazette International, February 2011.

2.13. ELECTRIC TRACTION DRIVES

2.13.1. Introduction

This page describes the way electric motors on locomotives and multiple units drive the axles and wheels.

2.13.2. The DC Traction Motor: How it Drives the Axle

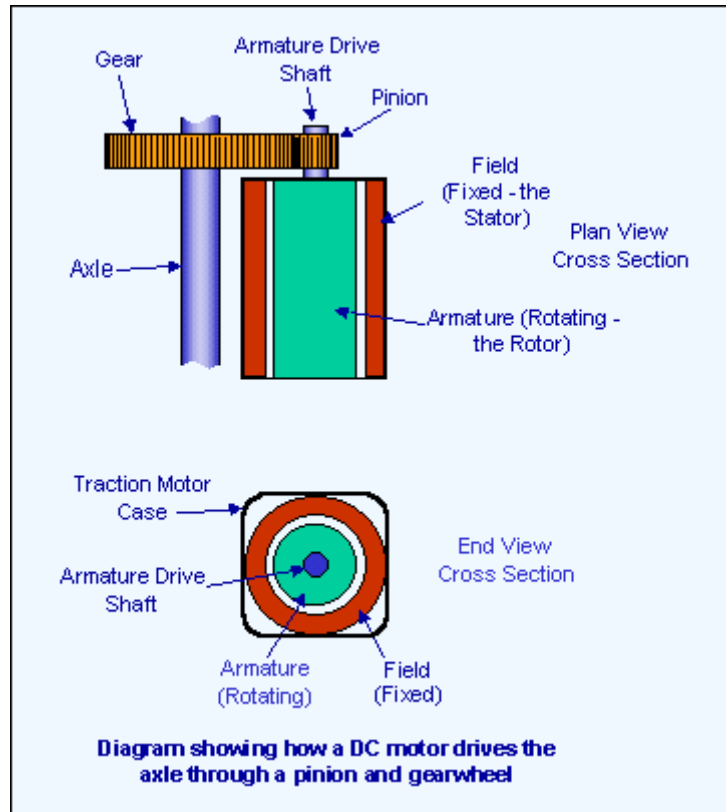

The traditional DC (Direct Current) electric motor driving a train or locomotive is a simple machine consisting of a case containing a fixed electrical part, the stator (called the stator because it is static and comprising what is called the field coils) and a moving electrical part, the rotor (because it rotates) or armature as it is often called. As the rotor turns, it turns a pinion which drives a gearwheel. The gearwheel is shrunk onto the axle and thus drives the wheels as shown in the diagram above.

The motion of the motor is created by the interaction of the magnetism caused by the currents flowing through the stator and the rotor. This interaction causes the rotor to turn and provide the drive.

The stator and the rotor of the DC motor are connected electrically. The connection consists of fixed, carbon brushes which are spring loaded so that they remain in contact with an extension of the armature called the commutator. In this way, the field coils (the stator) are kept in the circuit with the rotor (the armature and commutator).

2.13.3. AC and DC Motors

Both AC (Alternating Current) and DC motors have the same basic structure but there are differences and, for various reasons, the DC motor was originally the preferred form of motor for railway applications and most systems used it. Nowadays, modern power electronics has allowed the use of AC motors and, for most new equipments built today, the AC motor is the type used.

Often, people ask about the differences between AC and DC motors as used in locomotives and multiple-units. In the early days of electric traction at the beginning of this century both types were tried. The limits of the technology at the time favoured the DC motor. It provided the right torque characteristic for railway operation and was reasonably simple to control.

By the early 1980s, power electronics had progressed to the stage where the 3-phase AC motor became a serious and more efficient alternative to the DC motor because:

1. They are simpler to construct, they require no mechanical contacts to work (such as brushes) and they are lighter than DC motors for equivalent power.
2. Modern electronics allow AC motors to be controlled effectively to improve both adhesion and traction.
3. AC motors can be microprocessor controlled to a fine degree and can regenerate current down to almost a stop whereas DC regeneration fades quickly at low speeds.
4. They are more robust and easier to maintain than DC motors.

This type of motor is commonly called the Asynchronous Motor and was often referred to as the squirrel cage motor on account of its early design form. The photos below show a DC and an AC motor.

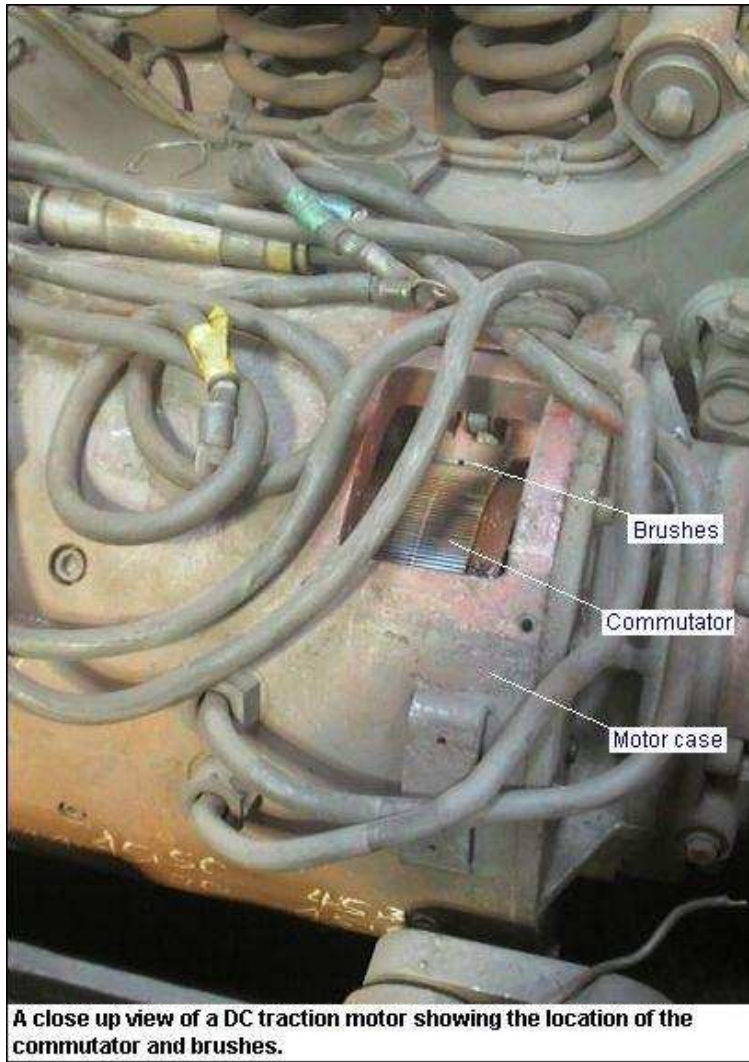

DC traction motor brushes

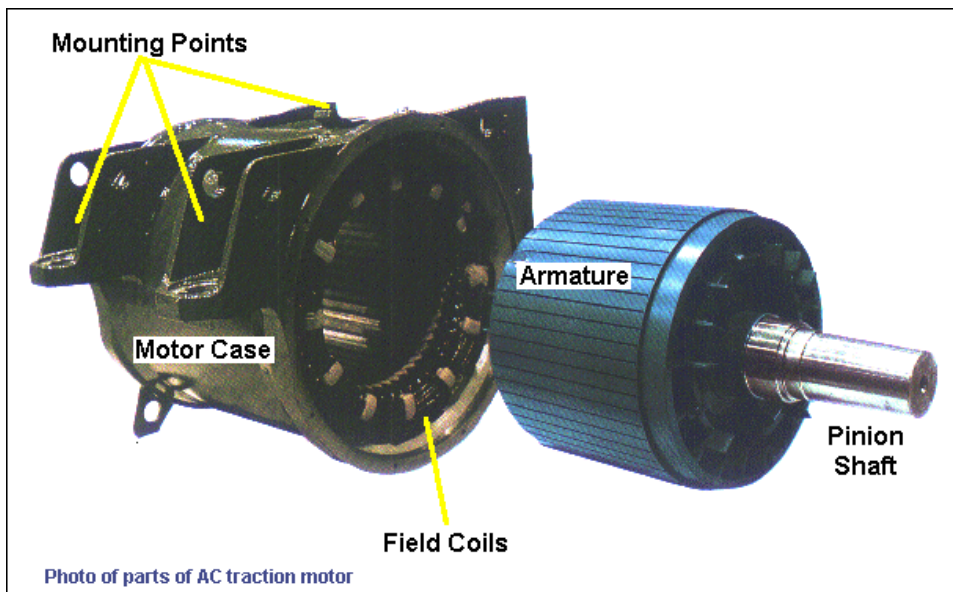

Modern AC traction motor

The DC motor is similar to look at externally but there are differences in construction, particularly because the DC motor has a commutator and brushes which the AC motor does not.

2.13.4. Nose Suspended Motor

The following diagram shows the layout of the traditional DC motor mounted in a bogie as a "nose suspended motor".

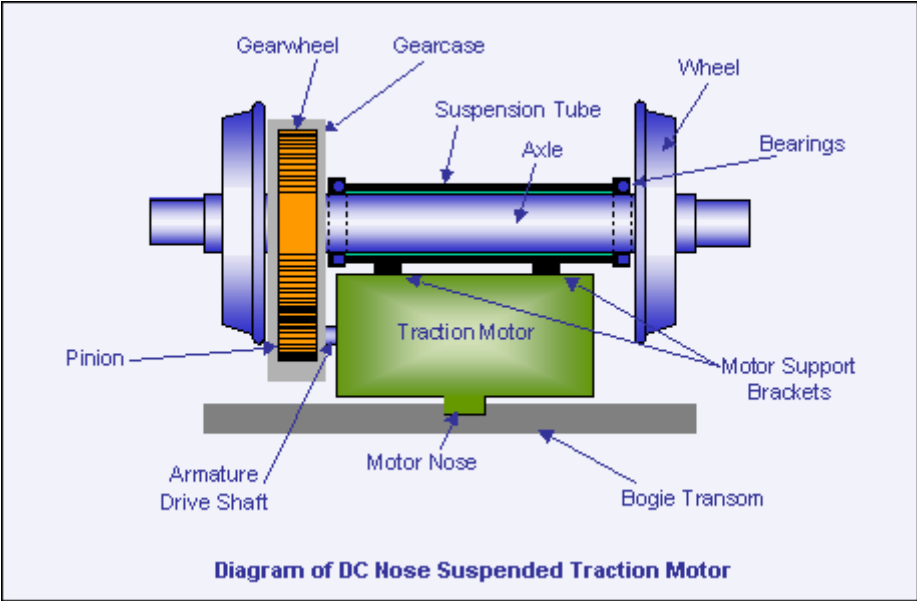

In electric trains or locomotives, the DC motor was traditionally mounted in the bogie frame supported partially by the axle which it drove and partially by the bogie frame. The motor case was provided with a "nose" which rested on a bracket fixed to the transom of the bogie. It was called a "nose suspended motor" (see diagram above) and is still common around the world. Its main disadvantage is that part of the weight rests on the axle and is therefore unsprung. This leads to greater wear on bogie and track. Nowadays, designers try to ensure all the motor weight is sprung by ensuring it is carried entirely by the bogie frame a frame mounted motor.

2.13.5. Quill Drive

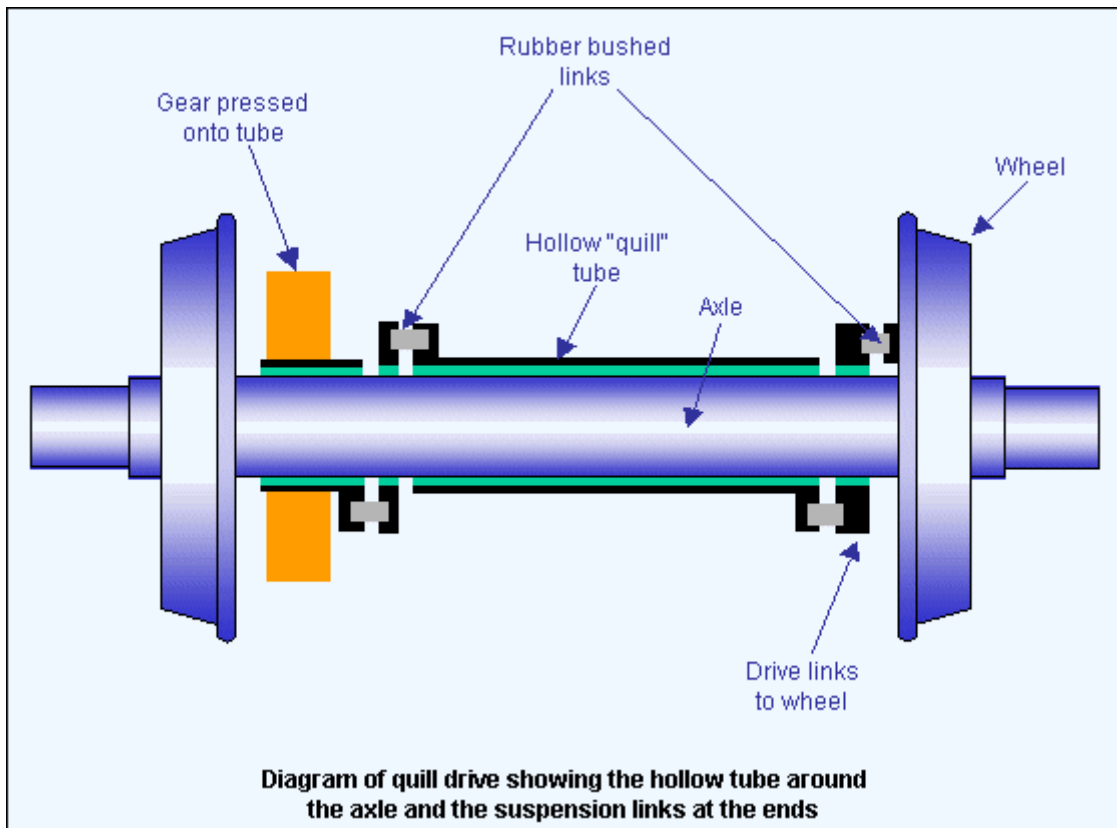

This is a simplified diagram of a quill drive. A quill is described in the dictionary as, "the hollow stem of a feather" and "a bobbin or spindle", as well as a "feather" and, alternatively, what a porcupine has on its back

In railway traction terms, a quill drive is where a hollow shaft is placed round the driving axle and the motor drives the quill rather than driving the axle as it does with a nose suspended drive. The quill itself is attached, at one end, to one of the wheels by means of rubber bushed links and, at the other end, to the gearwheel by similar links. The big advantage of such drives is that all the weight of the motor is carried in the bogie frame (so it is a frame mounted motor) instead of it being directly supported by the axle and therefore partially unsprung.

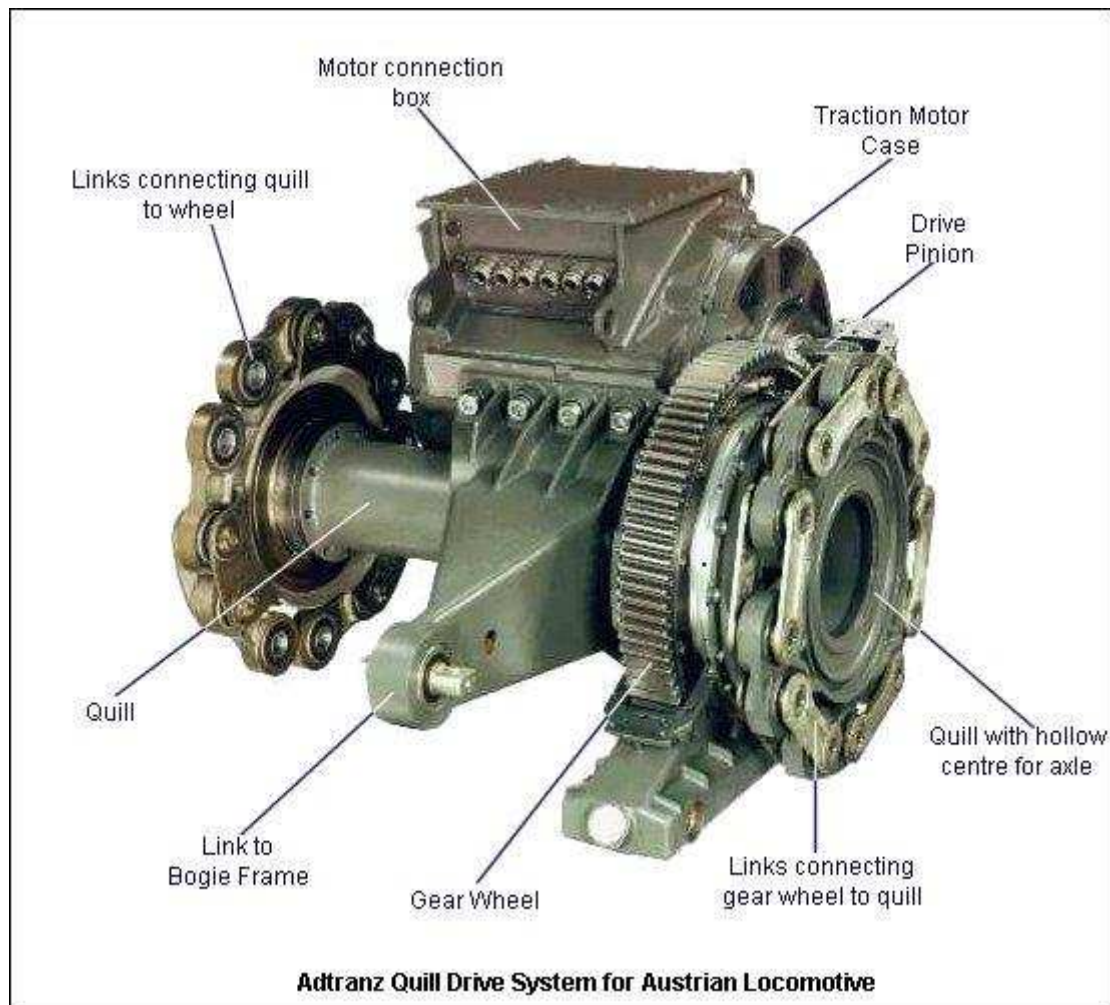

An example of a traction motor with quill drive appears in the following photo. Various forms of quill drive have been used over the years. Older versions used radially mounted coil steel springs instead of rubber to connect the links to the wheels. Some, like the example shown here, have the motor mounted parallel with the axle. Others have the motor at a right angle to the axle, as in the the UK Class 91 electric locomotives.

In German the quill is called "Hohlwelle" (hollow shaft) and used in the ICE1 and ICE2 as well as the electric locomotive Class 101. (Source Tobias Benjamin Koehler 19 Oct 98).

2.13.6. Monomotor Bogie

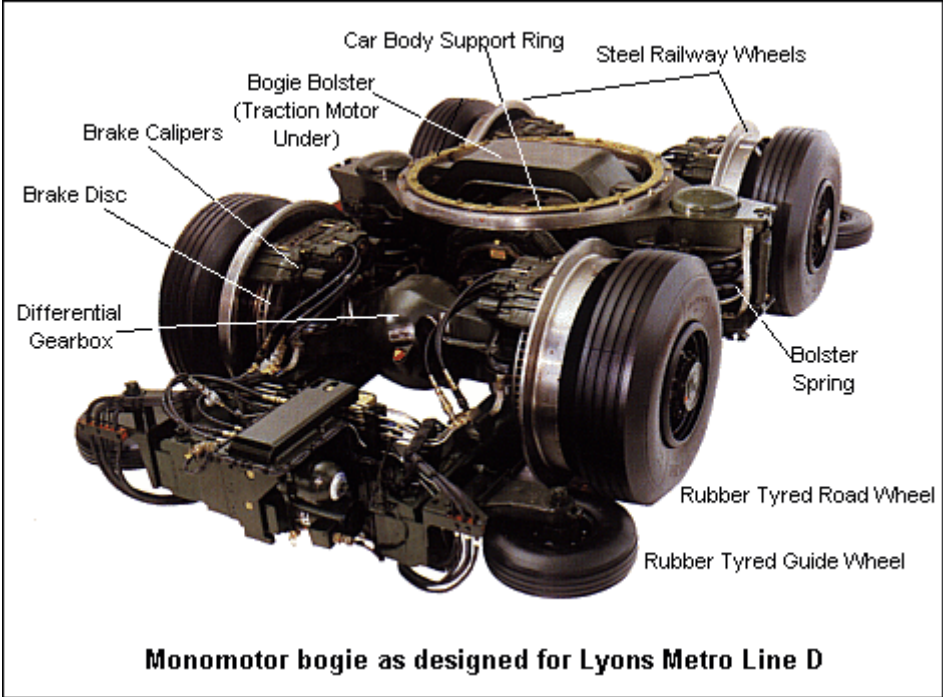

As its name implies, the monomotor bogie has a single motor which drives both axles.

The design is much favoured in France, where it was introduced in the 1950s for the rubber tyred train concept. The motor is mounted longitudinally in the centre of the bogie and drives each axle through a differential gearbox, similar to a road vehicle. The differential gears are required to compensate for the operation of the rubber tyres round curves. It requires a special bogie frame construction to accommodate the motor.

Another version of the monomotor bogie has also been applied to a number of French locomotive designs but here the arrangement is more conventional. Each bogie has a single motor mounted transversely over the centre as shown in the diagram left.

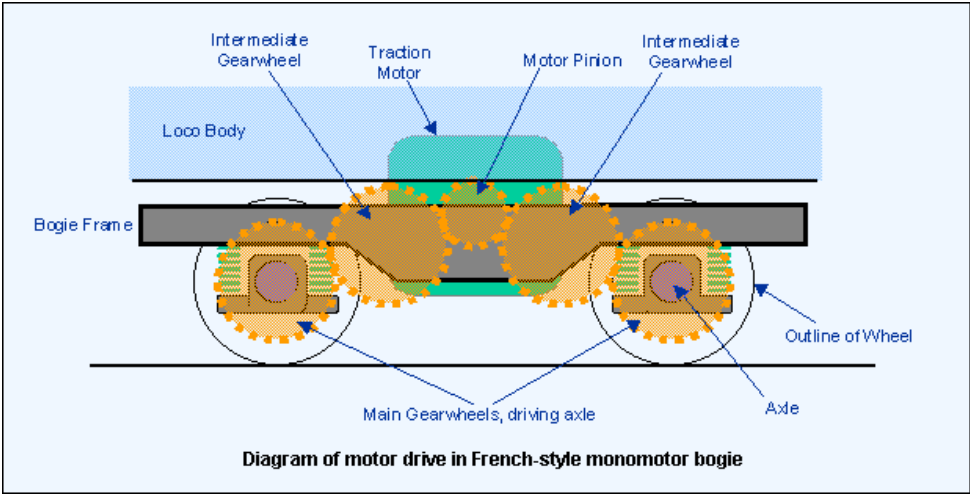

The motor is fully suspended in the bogie frame and drives both axles through the gear train, which is contained in a single, large, oil filled gearcase (not shown). This type of drive is referred to in the locomotive wheel arrangement called a B-B, as opposed to a more conventional locomotive with four motors, each driving its own axle, which is called a Bo-Bo.

2.13.7. Linear Motor

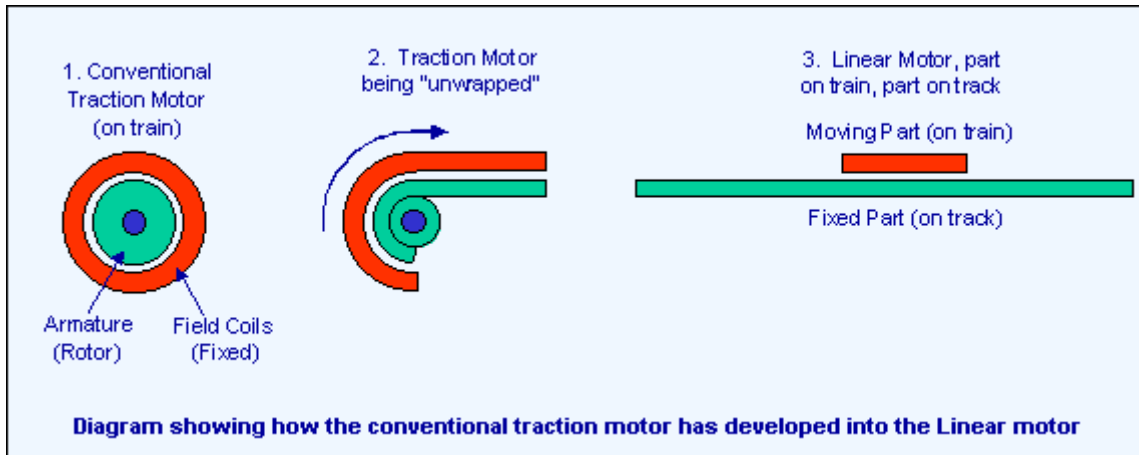

A new form of traction which has appeared in recent years is the linear motor. The principal, compared with a standard motor, is shown here. This simple diagram shows the principal of the linear motor. The conventional **DC motor** consists of a fixed part (the stator) and a moving part (the rotor). Both parts are contained in a case on the train and the rotor is connected to the axle by a pinion/gear arrangement. When the armature turns, the wheel turns.

The two parts of the linear motor are separated and one is placed on the train and the other on the the track. Both parts are unwrapped and they are swapped so that the fixed part of the DC motor becomes the moving part of the linear motor mounted on the train while the former moving part of the DC motor is fixed to the track. The electro-magnetic interaction between the current in the fixed part and that in the moving part causes the train to be drawn along the line. There is a very small air gap (about 10 mm) between the two parts as shown in this photo.

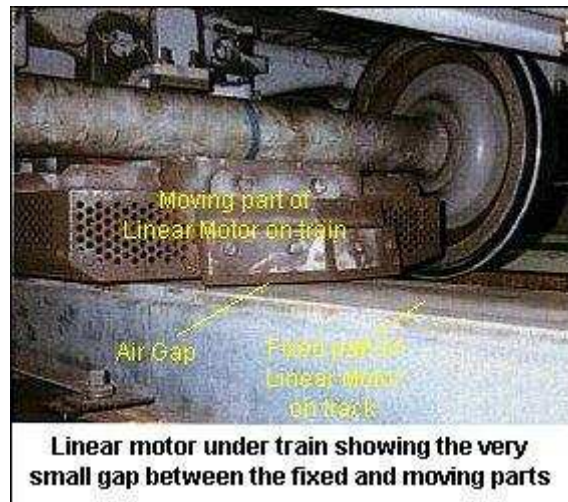

The efficiency of the linear motor is about 60% of the conventional motor but it has the advantage of less moving parts and it does not have the reliance on adhesion of the conventional motor.

2.14. DIESEL LOCOMOTIVE TECHNOLOGY

2.14.1. The Diesel Locomotive

The modern diesel locomotive is a self contained version of the electric locomotive. Like the electric locomotive, it has electric drive, in the form of traction motors driving the axles and controlled with electronic controls. It also has many of the same auxiliary systems for cooling, lighting, heating, braking and hotel power (if required) for the train. It can operate over the same routes (usually) and can be operated by the same drivers. It differs principally in that it carries its own generating station around with it, instead of being connected to a remote generating station through overhead wires or a third rail. The generating station consists of a large diesel engine coupled to an alternator producing the necessary electricity. A fuel tank is also essential. It is interesting to note that the modern diesel locomotive produces about 35% of the power of a electric locomotive of similar weight.



The UK Class 47 Co-Co diesel-electric locomotive, first introduced in 1962 and still regularly seen all over the country. The original engine was built to a Sulzer design and is a 12 cylinder, double bank machine rated at 2580 hp.

The UK Class 47 is typical of the general purpose diesel-electric locomotives introduced in the 1960s

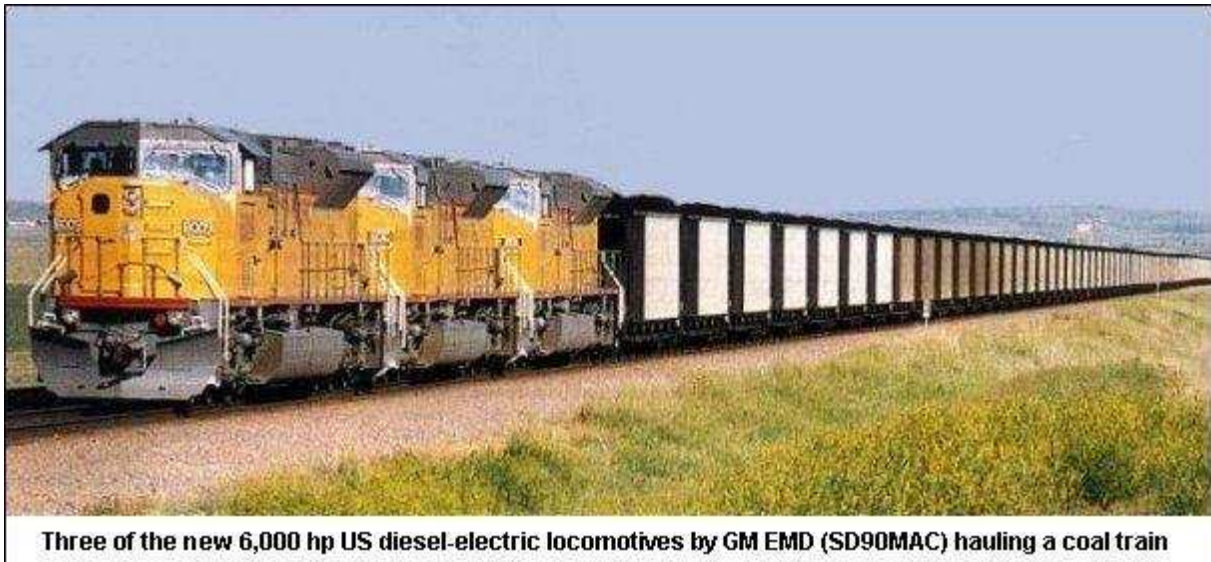

New SD90MAC 6,000 hp heavy freight US diesel-electric locomotives with AC drive first built in 1998

2.14.2. Parts of a Diesel-Electric Locomotive

The following diagram shows the main parts of a US-built diesel-electric locomotive.

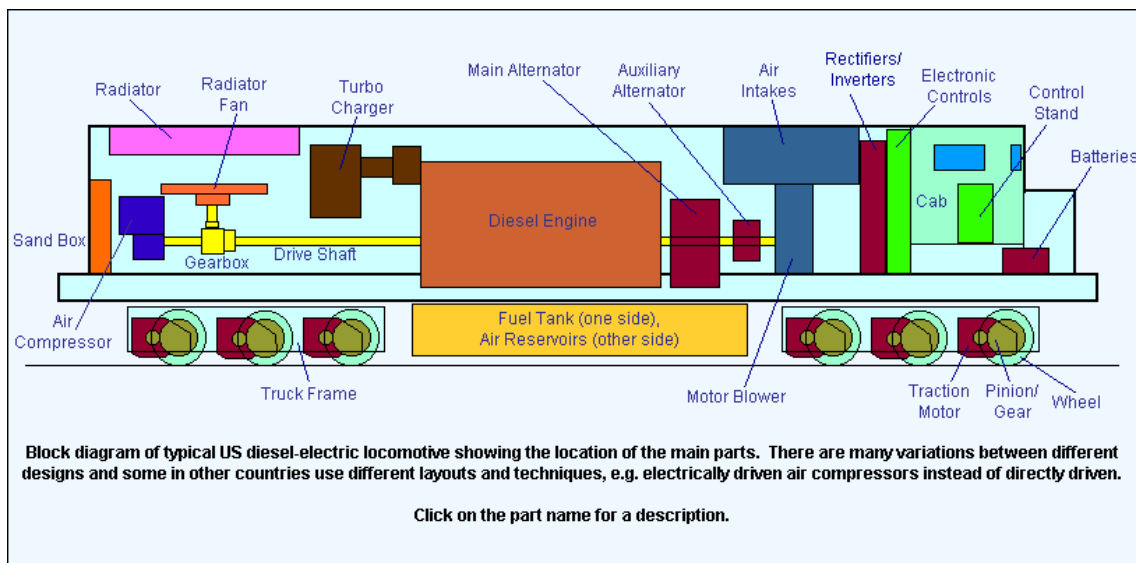

Diesel Engine

This is the main power source for the locomotive. It comprises a large cylinder block, with the cylinders arranged in a straight line or in a V. The engine rotates the drive shaft at up to 1,000 rpm and this drives the various items needed to power the locomotive. As the transmission is electric, the engine is used as the power source for the electricity generator or alternator, as it is called nowadays.

Main Alternator

The diesel engine drives the main alternator which provides the power to move the train. The alternator generates AC electricity which is used to provide power for the traction motors mounted on the trucks (bogies). In older locomotives, the alternator was a DC machine, called a generator. It produced direct current which was used to provide power for DC traction motors. Many of these machines are still in regular use. The next development was the replacement of the generator by the alternator but still using DC traction motors. The AC output is rectified to give the DC required for the motors

Auxiliary Alternator

Locomotives used to operate passenger trains are equipped with an auxiliary alternator. This provides AC power for lighting, heating, air conditioning, dining facilities etc. on the train. The output is transmitted along the train through an auxiliary power line. In the US, it is known as "head end power" or "hotel power". In the UK, air conditioned passenger coaches get what is called electric train supply (ETS) from the auxiliary alternator.

Motor Blower

The diesel engine also drives a motor blower. As its name suggests, the motor blower provides air which is blown over the traction motors to keep them cool during periods of heavy work. The blower is mounted inside the locomotive body but the motors are on the trucks, so the blower output is connected to each of the motors through flexible ducting. The blower output also cools the alternators. Some designs have separate blowers for the group of motors on each truck and others for the alternators. Whatever the arrangement, a modern locomotive has a complex air management system which monitors the temperature of the various rotating machines in the locomotive and adjusts the flow of air accordingly.

Air Intakes

The air for cooling the locomotive's motors is drawn in from outside the locomotive. It has to be filtered to remove dust and other impurities and its flow regulated by temperature, both inside and outside the locomotive. The air management system has to take account of the wide range of temperatures from the possible +40°C of summer to the possible -40°C of winter.

Rectifiers/Inverters

The output from the main alternator is AC but it can be used in a locomotive with either DC or AC traction motors. DC motors were the traditional type used for many years but, in the last 10 years, AC motors have become standard for new locomotives. They are cheaper to build and cost less to maintain and, with electronic management can be very finely controlled. To see more on the difference between DC and AC traction technology try the [Electronic Power Page](#) on this site.

To convert the AC output from the main alternator to DC, rectifiers are required. If the motors are DC, the output from the rectifiers is used directly. If the motors are AC, the DC output from the rectifiers is converted to 3-phase AC for the traction motors.

In the US, there are some variations in how the inverters are configured. GM EMD relies on one inverter per truck, while GE uses one inverter per axle both systems have their merits. EMD's system links the axles within each truck in parallel, ensuring wheel slip control is maximised among the axles equally. Parallel control also means even wheel wear even between axles. However, if one inverter (i.e. one truck) fails then the unit is only able to produce 50 per cent of its tractive effort. One inverter per axle is more complicated, but the GE view is that individual axle control can provide the best tractive effort. If an inverter fails, the tractive effort for that axle is lost, but full tractive effort is still available through the other five inverters. By controlling each axle individually, keeping wheel diameters closely matched for optimum performance is no longer necessary. This paragraph sourced from e-mail by unknown correspondent 3 November 1997.

Electronic Controls

Almost every part of the modern locomotive's equipment has some form of electronic control. These are usually collected in a control cubicle near the cab for easy access. The controls will usually include a maintenance management system of some sort which can be used to download data to a portable or hand-held computer.

Control Stand

This is the principal man-machine interface, known as a control desk in the UK or control stand in the US. The common US type of stand is positioned at an angle on the left side of the driving position and, it is said, is much preferred by drivers to the modern desk type of control layout usual in Europe and now being offered on some locomotives in the US.

Batteries

Just like an automobile, the diesel engine needs a battery to start it and to provide electrical power for lights and controls when the engine is switched off and the alternator is not running.

Cab

Most US diesel locomotives have only one cab but the practice in Europe is two cabs. US freight locos are also designed with narrow engine compartments and walkways along either side. This gives a reasonable forward view if the locomotive is working "hood forwards". US passenger locos, on the other hand have full width bodies and more streamlined ends but still usually with one cab. In Europe, it is difficult to tell the difference between a freight and passenger locomotive because the designs are almost all wide bodied and their use is often mixed.

Traction Motor

Since the diesel-electric locomotive uses electric transmission, traction motors are provided on the axles to give the final drive. These motors were traditionally DC but the development of modern power and control electronics has led to the introduction of 3-phase AC motors. For a description of how this technology works, go to the [Electronic Power Page](#) on this site. There are between four and six motors on most diesel-electric locomotives. A modern AC motor with air blowing can provide up to 1,000 hp.

Pinion/Gear

The traction motor drives the axle through a reduction gear of a range between 3 to 1 (freight) and 4 to 1 (passenger).

Fuel Tank

A diesel locomotive has to carry its own fuel around with it and there has to be enough for a reasonable length of trip. The fuel tank is normally under the loco frame and will have a capacity of say 1,000 imperial gallons (UK Class 59, 3,000 hp) or 5,000 US gallons in a General Electric AC4400CW 4,400 hp locomotive. The new AC6000s have 5,500 gallon tanks. In addition to fuel, the locomotive will carry around, typically about 300 US gallons of cooling water and 250 gallons of lubricating oil for the diesel engine.

Air reservoirs are also required for the train braking and some other systems on the locomotive. These are often mounted next to the fuel tank under the floor of the locomotive.

Air Compressor

The air compressor is required to provide a constant supply of compressed air for the locomotive and train brakes. In the US, it is standard practice to drive the compressor off the diesel engine drive shaft. In the UK, the compressor is usually electrically driven and can therefore be mounted anywhere. The Class 60 compressor is under the frame, whereas the Class 37 has the compressors in the nose.

Drive Shaft

The main output from the diesel engine is transmitted by the drive shaft to the alternators at one end and the radiator fans and compressor at the other end.

Gear Box

The radiator and its cooling fan is often located in the roof of the locomotive. Drive to the fan is therefore through a gearbox to change the direction of the drive upwards.

Radiator and Radiator Fan

The radiator works the same way as in an automobile. Water is distributed around the engine block to keep the temperature within the most efficient range for the engine. The water is cooled by passing it through a radiator blown by a fan driven by the diesel engine. See [Cooling](#) for more information.

Turbo Charging

The amount of power obtained from a cylinder in a diesel engine depends on how much fuel can be burnt in it. The amount of fuel which can be burnt depends on the amount of air available in the cylinder. So, if you can get more air into the cylinder, more fuel will be burnt and you will get more power out of your ignition. Turbo charging is used to increase the amount of air pushed into each cylinder. The turbocharger is driven by exhaust gas from the engine. This gas drives a fan which, in turn, drives a small compressor which pushes the additional air into the cylinder. Turbocharging gives a 50% increase in engine power.

The main advantage of the turbocharger is that it gives more power with no increase in fuel costs because it uses exhaust gas as drive power. It does need additional maintenance, however, so there are some type of lower power locomotives which are built without it.

Sand Box

Locomotives always carry sand to assist adhesion in bad rail conditions. Sand is not often provided on multiple unit trains because the adhesion requirements are lower and there are normally more driven axles.

Truck Frame

This is the part (called the bogie in the UK) carrying the wheels and traction motors of the locomotive.

Wheel

The best page for information on wheels is the [Wheels and Bogies Page](#) on this site.

2.14.3. Mechanical Transmission

A diesel-mechanical locomotive is the simplest type of diesel locomotive. As the name suggests, a mechanical transmission on a diesel locomotive consists a direct mechanical link between the diesel engine and the wheels. In the example below, the diesel engine is in the 350-500 hp range and the transmission is similar to that of an automobile with a four speed gearbox. Most of the parts are similar to the diesel-electric locomotive but there are some variations in design mentioned below.

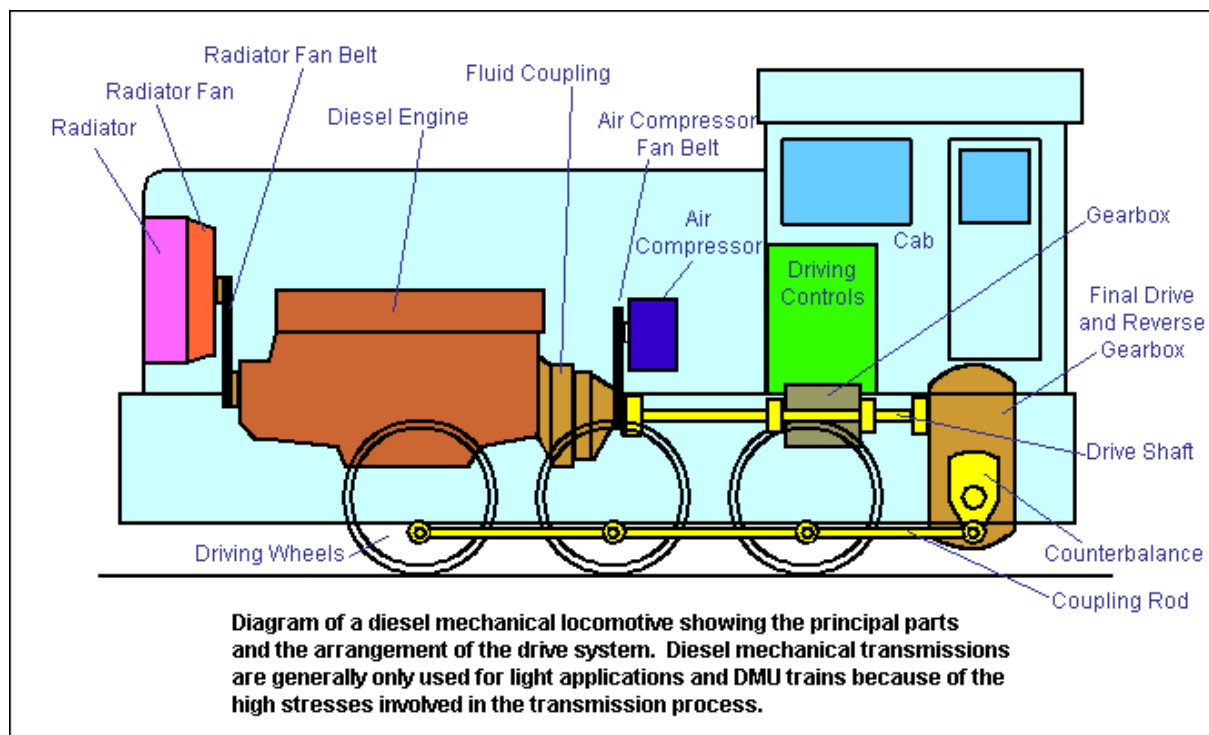

Fluid Coupling

In a diesel-mechanical transmission, the main drive shaft is coupled to the engine by a fluid coupling. This is a hydraulic clutch, consisting of a case filled with oil, a rotating disc with curved blades driven by the engine and another connected to the road wheels. As the engine turns the fan, the oil is driven by one disc towards the other. This turns under the force of the oil and thus turns the drive shaft. Of course, the start up is gradual until the fan speed is almost matched by the blades. The whole system acts like an automatic clutch to allow a graduated start for the locomotive.

Gearbox

This does the same job as that on an automobile. It varies the gear ratio between the engine and the road wheels so that the appropriate level of power can be applied to the wheels. Gear change is manual. There is no need for a separate clutch because the functions of a clutch are already provided in the fluid coupling.

Final Drive

The diesel-mechanical locomotive uses a final drive similar to that of a steam engine. The wheels are coupled to each other to provide more adhesion. The output from the 4-speed gearbox is coupled to a final drive and reversing gearbox which is provided with a transverse drive shaft and balance weights. This is connected to the driving wheels by connecting rods.

2.14.4. Hydraulic Transmission

Hydraulic transmission works on the same principal as the fluid coupling but it allows a wider range of "slip" between the engine and wheels. It is known as a "torque converter". When the train speed has increased sufficiently to match the engine speed, the fluid is drained out of the torque converter so that the engine is virtually coupled directly to the locomotive wheels. It is virtually direct because the coupling is usually a fluid coupling, to give some "slip". Higher speed locomotives use two or three torque converters in a sequence similar to gear changing in a mechanical transmission and some have used a combination of torque converters and gears.

Some designs of diesel-hydraulic locomotives had two diesel engines and two transmission systems, one for each bogie. The design was popular in Germany (the V200 series of locomotives, for example) in the 1950s and was imported into parts of the UK in the 1960s. However, it did not work well in heavy or express locomotive designs and has largely been replaced by diesel-electric transmission.

2.14.5. Wheel Slip

Wheels slip is the bane of the driver trying to get a train away smoothly. The tenuous contact between steel wheel and steel rail is one of the weakest parts of the railway system. Traditionally, the only cure has been a combination of the skill of the driver and the selective use of sand to improve the adhesion. Today, modern electronic control has produced a very effective answer to this age old problem. The system is called creep control.

Extensive research into wheel slip showed that, even after a wheelset starts to slip, there is still a considerable amount of useable adhesion available for traction. The adhesion is available up to a peak, when it will rapidly fall away to an uncontrolled spin. Monitoring the early stages of slip can be used to adjust the power being applied to the wheels so that the adhesion is kept within the limits of the "creep" towards the peak level before the uncontrolled spin sets in.

The slip is measured by detecting the locomotive speed by Doppler radar (instead of the usual method using the rotating wheels) and comparing it to the motor current to see if the wheel rotation matches the ground speed. If there is a disparity between the two, the motor current is adjusted to keep the slip within the "creep" range and keep the tractive effort at the maximum level possible under the creep conditions.

2.14.6. Diesel Multiple Units (DMUs)

The diesel engines used in DMUs work on exactly the same principles as those used in locomotives, except that the transmission is normally mechanical with some form of gear change system. DMU engines are smaller and several are used on a train, depending on the configuration. The diesel engine is often mounted under the car floor and on its side because of the restricted space available. Vibration being transmitted into the passenger saloon has always been a problem but some of the newer designs are very good in this respect.

There are some diesel-electric DMUs around and these normally have a separate engine compartment containing the engine and the generator or alternator.

2.14.7. The Diesel Engine

The diesel engine was first patented by Dr Rudolf Diesel (1858-1913) in Germany in 1892 and he actually got a successful engine working by 1897. By 1913, when he died, his engine was in use on locomotives and he had set up a facility with Sulzer in Switzerland to manufacture them. His death was mysterious in that he simply disappeared from a ship taking him to London.

The diesel engine is a compression-ignition engine, as opposed to the petrol (or gasoline) engine, which is a spark-ignition engine. The spark ignition engine uses an electrical spark from a "spark plug" to ignite the fuel in the engine's cylinders, whereas the fuel in the diesel engine's cylinders is ignited by the heat caused by air being suddenly compressed in the cylinder. At this stage, the air gets compressed into an area 1/25th of its original volume. This would be expressed as a compression ratio of 25 to 1. A compression ratio of 16 to 1 will give an air pressure of 500 lbs/in² (35.5 bar) and will increase the air temperature to over 800°F (427°C).

The advantage of the diesel engine over the petrol engine is that it has a higher thermal capacity (it gets more work out of the fuel), the fuel is cheaper because it is less refined than petrol and it can do heavy work under extended periods of overload. It can however, in a high speed form, be sensitive to maintenance and noisy, which is why it is still not popular for passenger automobiles.

2.14.8. Diesel Engine Types

There are two types of diesel engine, the two-stroke engine and the four-stroke engine. As the names suggest, they differ in the number of movements of the piston required to complete each cycle of operation. The simplest is the two-stroke engine. It has no valves. The exhaust from the combustion and the air for the new stroke is drawn in through openings in the cylinder wall as the piston reaches the bottom of the downstroke. Compression and combustion occurs on the upstroke. As one might guess, there are twice as many revolutions for the two-stroke engine as for equivalent power in a four-stroke engine.

The four-stroke engine works as follows: Downstroke 1 - air intake, upstroke 1 - compression, downstroke 2 power, upstroke 2 exhaust. Valves are required for air intake and exhaust, usually two for each. In this respect it is more similar to the modern petrol engine than the 2-stroke design.

In the UK, both types of diesel engine were used but the 4-stroke became the standard. The UK Class 55 "Deltic" (not now in regular main line service) unusually had a two-stroke engine. In the US, the General Electric (GE) built locomotives have 4-stroke engines whereas General Motors (GM) always used 2-stroke engines until the introduction of their SD90MAC 6000 hp "H series" engine, which is a 4-stroke design.

The reason for using one type or the other is really a question of preference. However, it can be said that the 2-stroke design is simpler than the 4-stroke but the 4-stroke engine is more fuel efficient.

2.14.9. Size Does Count

Basically, the more power you need, the bigger the engine has to be. Early diesel engines were less than 100 horse power (hp) but today the US is building 6000 hp locomotives. For a UK locomotive of 3,300 hp (Class 58), each cylinder will produce about 200 hp, and a modern engine can double this if the engine is [turbocharged](#).

The maximum rotational speed of the engine when producing full power will be about 1000 rpm (revolutions per minute) and the engine will idle at about 400 rpm. These relatively low speeds mean that the engine design is heavy, as opposed to a high speed, lightweight engine. However, the UK HST (High Speed Train, developed in the 1970s) engine has a speed of 1,500 rpm and this is regarded as high speed in the railway diesel engine category. The slow, heavy engine used in railway locomotives will give low maintenance requirements and an extended life.

There is a limit to the size of the engine which can be accommodated within the railway loading gauge, so the power of a single locomotive is limited. Where additional power is required, it has become usual to add locomotives. In the US, where freight trains run into tens of thousands of tons weight, four locomotives at the head of a train are common and several additional ones in the middle or at the end are not unusual.

2.14.10. To V or not to V

Diesel engines can be designed with the cylinders "in-line", "double banked" or in a "V". The double banked engine has two rows of cylinders in line. Most diesel locomotives now have V form engines. This means that the cylinders are split into two sets, with half forming one side of the V. A V8 engine has 4 cylinders set at an angle forming one side of the V with the other set of four forming the other side. The crankshaft, providing the drive, is at the base of the V. The V12 was a popular design used in the UK. In the US, V16 is usual for freight locomotives and there are some designs with V20 engines.

Engines used for DMU (diesel multiple unit) trains in the UK are often mounted under the floor of the passenger cars. This restricts the design to in-line engines, which have to be mounted on their side to fit in the restricted space.

An unusual engine design was the UK 3,300 hp Class 55 locomotive, which had the cylinders arranged in three sets of opposed Vs in an triangle, in the form of an upturned delta, hence the name "Deltic".

2.14.11. Tractive Effort, Pull and Power

Before going too much further, we need to understand the definitions of tractive effort, drawbar pull and power. The definition of tractive effort (TE) is simply the force exerted at the wheel rim of the locomotive and is usually expressed in pounds (lbs) or kilo Newtons (kN). By the time the tractive effort is transmitted to the coupling between the locomotive and the train, the drawbar pull, as it is called will have reduced because of the friction of the mechanical parts of the drive and some wind resistance.

Power is expressed as horsepower (hp) or kilo Watts (kW) and is actually a rate of doing work. A unit of horsepower is defined as the work involved by a horse lifting 33,000 lbs one foot in one minute. In the metric system it is calculated as the power (Watts) needed when one Newton of force is moved one metre in one second. The formula is $P = (F*d)/t$ where P is power, F is force, d is distance and t is time. One horsepower equals 746 Watts.

The relationship between power and drawbar pull is that a low speed and a high drawbar pull can produce the same power as high speed and low drawbar pull. If you need to increase higher tractive effort and high speed, you need to increase the power. To get the variations needed by a locomotive to operate on the railway, you need to have a suitable means of transmission between the diesel engine and the wheels.

One thing worth remembering is that the power produced by the diesel engine is not all available for traction. In a 2,580 hp diesel electric locomotive, some 450 hp is lost to on-board equipment like blowers, radiator fans, air compressors and "hotel power" for the train.

2.14.12. Starting

A diesel engine is started (like an automobile) by turning over the crankshaft until the cylinders "fire" or begin combustion. The starting can be done electrically or pneumatically. Pneumatic starting was used for some engines. Compressed air was pumped into the cylinders of the engine until it gained sufficient speed to allow ignition, then fuel was applied to fire the engine. The compressed air was supplied by a small auxiliary engine or by high pressure air cylinders carried by the locomotive.

Electric starting is now standard. It works the same way as for an automobile, with batteries providing the power to turn a starter motor which turns over the main engine. In older locomotives fitted with DC generators instead of AC alternators, the generator was used as a starter motor by applying battery power to it.

2.14.13. Governor

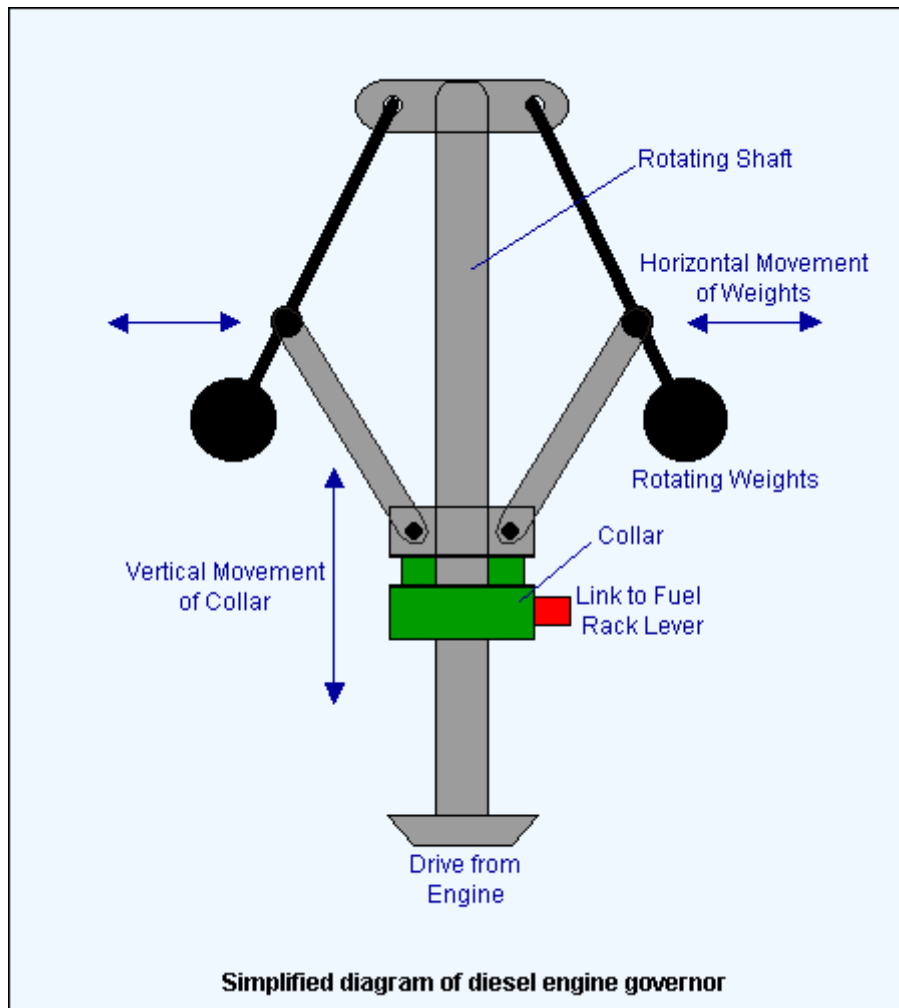

Once a diesel engine is running, the engine speed is monitored and controlled through a governor. The governor ensures that the engine speed stays high enough to idle at the right speed and that the engine speed will not rise too high when full power is demanded. The governor is a simple mechanical device which first appeared on steam engines. It operates on a diesel engine as shown in the diagram below.

The governor consists of a rotating shaft, which is driven by the diesel engine. A pair of flyweights are linked to the shaft and they rotate as it rotates. The centrifugal force caused by the rotation causes the weights to be thrown outwards as the speed of the shaft rises. If the speed falls the weights move inwards.

The flyweights are linked to a collar fitted around the shaft by a pair of arms. As the weights move out, so the collar rises on the shaft. If the weights move inwards, the collar moves down the shaft. The movement of the collar is used to operate the fuel rack lever controlling the amount of fuel supplied to the engine by the injectors.

2.14.14. Fuel Injection

Ignition in a diesel engine is achieved by compressing air inside a cylinder until it gets very hot (say 400°C, almost 800°F) and then injecting a fine spray of fuel oil to cause a miniature explosion. The explosion forces down the piston in the cylinder and this turns the crankshaft. To get the fine spray needed for successful ignition the fuel has to be pumped into the cylinder at high pressure. The fuel pump is operated by a cam driven off the engine. The fuel is pumped into an injector, which gives the fine spray of fuel required in the cylinder for combustion.

2.14.15. Fuel Control

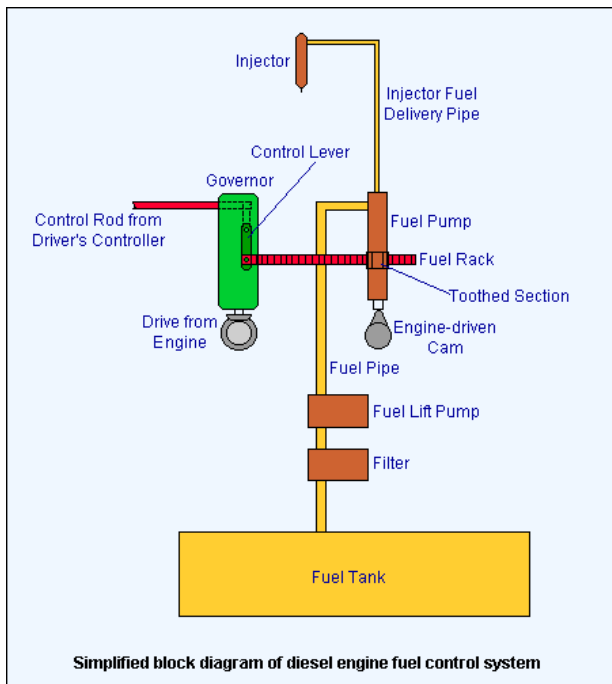

In an automobile engine, the power is controlled by the amount of fuel/air mixture applied to the cylinder. The mixture is mixed outside the cylinder and then applied by a throttle valve. In a diesel engine the amount of air applied to the cylinder is constant so power is regulated by varying the fuel input. The fine spray of fuel injected into each cylinder has to be regulated to achieve the amount of power required. Regulation is achieved by varying the fuel sent by the fuel pumps to the injectors. The control arrangement is shown in the diagram left.

The amount of fuel being applied to the cylinders is varied by altering the effective delivery rate of the piston in the injector pumps. Each injector has its own pump, operated by an engine-driven cam, and the pumps are aligned in a row so that they can all be adjusted together. The adjustment is done by a toothed rack (called the "fuel rack") acting on a toothed section of the pump mechanism. As the fuel rack moves, so the toothed section of the pump rotates and provides a drive to move the pump piston round inside the pump. Moving the piston round, alters the size of the channel available inside the pump for fuel to pass through to the injector delivery pipe.

The fuel rack can be moved either by the driver operating the power controller in the cab or by the governor. If the driver asks for more power, the control rod moves the fuel rack to set the pump pistons to allow more fuel to the injectors. The engine will increase power and the governor will monitor engine speed to ensure it does not go above the

predetermined limit. The limits are fixed by springs (not shown) limiting the weight movement.

2.14.16. Engine Control Development

So far we have seen a simple example of diesel engine control but the systems used by most locomotives in service today are more sophisticated. To begin with, the drivers control was combined with the governor and hydraulic control was introduced. One type of governor uses oil to control the fuel racks hydraulically and another uses the fuel oil pumped by a gear pump driven by the engine. Some governors are also linked to the turbo charging system to ensure that fuel does not increase before enough turbocharged air is available. In the most modern systems, the governor is electronic and is part of a complete engine management system.

2.14.17. Power Control

The diesel engine in a diesel-electric locomotive provides the drive for the main alternator which, in turn, provides the power required for the traction motors. We can see from this therefore, that the power required from the diesel engine is related to the power required by the motors. So, if we want more power from the motors, we must get more current from the alternator so the engine needs to run faster to generate it. Therefore, to get the optimum performance from the locomotive, we must link the control of the diesel engine to the power demands being made on the alternator.

In the days of generators, a complex electro-mechanical system was developed to achieve the feedback required to regulate engine speed according to generator demand. The core of the system was a load regulator, basically a variable resistor which was used to vary the excitation of the generator so that its output matched engine speed. The control sequence (simplified) was as follows:

1. Driver moves the power controller to the full power position
2. An air operated piston actuated by the controller moves a lever, which closes a switch to supply a low voltage to the load regulator motor.
3. The load regulator motor moves the variable resistor to increase the main generator field strength and therefore its output.
4. The load on the engine increases so its speed falls and the governor detects the reduced speed.
5. The governor weights drop and cause the fuel rack servo system to actuate.

6. The fuel rack moves to increase the fuel supplied to the injectors and therefore the power from the engine.

7. The lever (mentioned in 2 above) is used to reduce the pressure of the governor spring.

8. When the engine has responded to the new control and governor settings, it and the generator will be producing more power.

On locomotives with an alternator, the load regulation is done electronically. Engine speed is measured like modern speedometers, by counting the frequency of the gear teeth driven by the engine, in this case, the starter motor gearwheel. Electrical control of the fuel injection is another improvement now adopted for modern engines. Overheating can be controlled by electronic monitoring of coolant temperature and regulating the engine power accordingly. Oil pressure can be monitored and used to regulate the engine power in a similar way.

2.14.18. Cooling

Like an automobile engine, the diesel engine needs to work at an optimum temperature for best efficiency. When it starts, it is too cold and, when working, it must not be allowed to get too hot. To keep the temperature stable, a cooling system is provided. This consists of a water-based coolant circulating around the engine block, the coolant being kept cool by passing it through a radiator.

The coolant is pumped round the cylinder block and the radiator by an electrically or belt driven pump. The temperature is monitored by a thermostat and this regulates the speed of the (electric or hydraulic) radiator fan motor to adjust the cooling rate. When starting the coolant isn't circulated at all. After all, you want the temperature to rise as fast as possible when starting on a cold morning and this will not happen if you are blowing cold air into your radiator. Some radiators are provided with shutters to help regulate the temperature in cold conditions.

If the fan is driven by a belt or mechanical link, it is driven through a fluid coupling to ensure that no damage is caused by sudden changes in engine speed. The fan works the same way as in an automobile, the air blown by the fan being used to cool the water in the radiator. Some engines have fans with an electrically or hydrostatically driven motor. An hydraulic motor uses oil under pressure which has to be contained in a special reservoir and pumped to the motor. It has the advantage of providing an in-built fluid coupling.

A problem with engine cooling is cold weather. Water freezes at 0°C or 32°F and frozen cooling water will quickly split a pipe or engine block due to the expansion of the water as it freezes. Some systems are "self draining" when the engine is stopped and most in Europe are designed to use a mixture of anti-freeze, with Gycol and some form of rust inhibitor. In the US, engines do not normally contain anti-freeze, although the new GM EMD "H" engines are designed to use it. Problems with leaks and seals and the expense of putting a 100 gallons (378.5 litres) of coolant into a 3,000 hp engine, means that engines in the US have traditionally operated without it. In cold weather, the engine is left running or the locomotive is kept warm by putting it into a heated building or by plugging in a shore supply. Another reason for keeping diesel engines running is that the constant heating and cooling caused by shutdowns and restarts, causes stresses in the block and pipes and tends to produce leaks.

2.14.19. Lubrication

Like an automobile engine, a diesel engine needs lubrication. In an arrangement similar to the engine cooling system, lubricating oil is distributed around the engine to the cylinders, crankshaft and other moving parts. There is a reservoir of oil, usually carried in the sump, which has to be kept topped up, and a pump to keep the oil circulating evenly around the engine. The oil gets heated by its passage around the engine and has to be kept cool, so it is passed through a radiator during its journey. The radiator is sometimes designed as a heat exchanger, where the oil passes through pipes encased in a water tank which is connected to the engine cooling system.

The oil has to be filtered to remove impurities and it has to be monitored for low pressure. If oil pressure falls to a level which could cause the engine to seize up, a "low oil pressure switch" will shut down the engine. There is also a high pressure relief valve, to drain off excess oil back to the sump.

2.14.20. Transmissions

Like an automobile, a diesel locomotive cannot start itself directly from a stand. It will not develop maximum power at idling speed, so it needs some form of transmission system to multiply torque when starting. It will also be necessary to vary the power applied according to the train weight or the line gradient. There are three methods of doing this: mechanical, hydraulic or electric. Most diesel locomotives use electric transmission and are called "diesel-electric" locomotives. Mechanical and hydraulic transmissions are still used but are more common on multiple unit trains or lighter locomotives.

2.14.21. Diesel-Electric Types

Diesel-electric locomotives come in three varieties, according to the period in which they were designed. These three are:

DC DC (DC generator supplying DC traction motors); AC - DC (AC alternator output rectified to supply DC motors) and AC - DC - AC (AC alternator output rectified to DC and then inverted to 3-phase AC for the traction motors).

The DC - DC type has a generator supplying the DC traction motors through a resistance control system, the AC - DC type has an alternator producing AC current which is rectified to DC and then supplied to the DC traction motors and, finally, the most modern has the AC alternator output being rectified to DC and then converted to AC (3-phase) so that it can power the 3-phase AC traction motors. Although this last system might seem the most complex, the gains from using AC motors far outweigh the apparent complexity of the system. In reality, most of the equipment uses solid state power electronics with microprocessor-based controls. For more details on AC and DC traction, see the [Electronic Power Page](#) on this site.

In the US, traction alternators (AC) were introduced with the 3000 hp single diesel engine locomotives, the first being the Alco C630. The SD40, SD45 and GP40 also had traction alternators only. On the GP38, SD38, GP39, and SD39s, traction generators (DC) were standard, and traction alternators were optional, until the dash-2 era, when they became standard. It was a similar story at General Electric.

There is one traction alternator (or generator) per diesel engine in a locomotive (standard North American practice anyway). The Alco C628 was the last locomotive to lead the horsepower race with a DC traction alternator.

2.15. ROLLING STOCK MANUFACTURING

2.15.1. Introduction

All you wanted to know about how railway rolling stock is designed, manufactured, assembled, tested and shipped but were afraid to ask. Most of this page was written by Paul Berkley, who also supplied many of the photographs, and it was then edited with additional material from Nick Cory.

2.15.2. The Process

Railway rolling stock manufacturing consists of a series of stages which begin with the signing of an order and culminate in the entry into service of a new train. These stages consist of signing the contract, doing the design, ordering materials and parts, manufacturing and assembly, testing and delivery. It is a costly and time consuming business and there is a lot of risk in the process because a lot can go wrong. Apart from the technical difficulties of designing and building a complex, multi-million dollar project, everyone wants to play trains and interfere with the design, especially politicians and newspaper editors, both of whom have one thing in common - they know nothing about railways.

2.15.3. Timescales

So you want to buy a new train or locomotive? How long will it be before it is carrying passengers or hauling cars? Well, give yourself four years from the date you decide to buy. It can be done more quickly a new locomotive order in the UK was once famous for having its first loco delivered 18 months after contract signing but 3 or 4 years is more usual. Here, I am assuming that it is a new design, not a run-on order and that there will be over 80 new vehicles. I am also assuming that you know how many trains or locomotives you need and what the general basic design will need to be. The procurement process will occupy at least a year longer if you need finance from the commercial market.

So let's say you give the supplier Notice To Proceed (NTP) a year after you go to market. The design process will have already begun, since the supplier will have prepared a concept design as part of the bidding process. By the time he gets NTP, he will have got to a stage with his customer where he knows he is the preferred bidder and he will have started more detailed basic design work.

Six months after NTP, parts manufacture will start and, six months after that the first body might be ready for installation of its equipment and interior finishes. Give it another year for completion of equipping and a lot of testing before it is ready for shipping. Three years have gone already and the first car has still only just rolled out of the factory door.

Acceptance testing on site and bureaucratic approvals may last months (at least a year in the UK) before the train finally enters service. There is some slack in this broad outline because I am sure there will be technical problems on the way but we have used up our four years. Locomotives may take less as each one can operate as a unit and isn't dependent on other vehicles like an EMU ([Electric Multiple Unit](#)).

2.15.4. Design

This is where it all begins. Design work starts during the bidding process. The customer will issue an "invitation to tender" (ITT) and then wait for the rush. Rush? Well, not quite. It starts with the supplier producing an outline design, which is prepared against the ITT and then costed. These days, most manufacturers have created their own catalogue of vehicles that they would like to sell because they can build to pre-existing designs and offer them at a more competitive price. The designs are offered in modular form so they can be customised to suit the buyer's needs. Unfortunately, a contract (particularly one procured by a publicly-funded administration) is rarely as simple as this and, usually, the potential customer will have produced a specification that he wants his vehicle designed to. Invariably, this will not fit conveniently into the little niche of standard designs that the supplier hoped it would. Of course, this puts the price up. Many customers are now trying to procure through performance specifications, where the dimensions, capacity, speed, power requirements and reliability are specified rather than details like the make of door engines or colour of the upholstery for the driver's seat. This gives the supplier the chance to adopt standardisation in many areas, but many customers still fall into the trap of asking for a bespoke train and then wondering why it is so expensive.

Now, let us assume that the preliminary design was accepted, a price agreed and a contract awarded. The engineering design office (henceforth referred to as the DO - originally short for drawing office) will now swing into action and start developing a plan for the design work of the vehicle, which will include producing a Bill of Materials (BoM) that will identify all the details necessary to manufacture the vehicle. A preliminary list of drawings will be tied in with the BoM and there will probably be in excess of 3000 drawings needed. Meetings will be held with the purchasing and production departments to determine priorities for preparation of designs.

During the bidding phase, the DO will contact various sub-suppliers of brakes, lighting, seats, propulsion, traction motors etc. about the specifications, to determine who can, or is willing to meet the performance requirements. If you look at a piece of rolling stock, it is easy to see that the supplier is really just an assembler of many parts that are purchased from other suppliers. Perhaps all he has is a specialist shop for manufacture of the car bodyshell and one for the wiring looms, and the rest of the vehicle is bought from

someone else. Some car builders, like Brush Traction in the UK, even buy complete locomotive body shells and bogies from external suppliers. However it is done, the vehicle design and assembly concept will eventually come together and some preliminary design drawings will be produced for presentation to the customer.

2.15.5. Long Lead Ordering

It is at this point that some long lead items will be ordered. Steel, some types at least, can have a three-month lead time, especially if you want a special finish for an unpainted vehicle. Cables can require a six month lead time, particularly if they are of special fire proof or low toxicity specification. Car interior panels may also require specialist materials with long manufacturing periods. Of course, once you order these things, you are locked into the design, so you'd better be sure you get it right.

2.15.6. Jigs and Tools



Another area which needs to be sorted out early is jigs and tools. The car body parts will have to be assembled in jigs to ensure that they are held rigidly and in the correct position during welding. The body shell itself will also require a large jig to assist in the assembly. Jigs cannot be designed until the body form is known and the construction methods agreed.

A jig is basically either a steel bed, shaped to carry the section to be welded, or it a series of specially formed steel frames, upon which parts will be fixed while they are

welded. The jigs will be fitted with adjustable clamps which will hold each piece in its correct position for welding. Jigs come in all shapes and sizes, depending on the part or parts to be assembled and the welding system to be used. Jig design is an art in itself and many a project has been a success or a failure because of the quality, or lack of it, of the jigs.



Underframe assembly in a heavy jig where the solebars and transoms are welded. It is essential to ensure all parts are held to strict limits to prevent distortion during welding.



Body-side assembly jig. It is shaped to match the body curvature. The panels and their internal strengthening members are held in place by clamps while being welded.

Body-side assembly jig. It is shaped to match the body curvature. The panels and their internal strengthening members are held in place by clamps while being welded.



The roofing jig, where the parts are clamped to provide stability during welding. The roof is one of the more difficult parts of the car to weld as it is thin and tends to distort easily.

The roofing jig, where the parts are clamped to provide stability during welding. The roof is one of the more difficult parts of the car to weld as it is thin and tends to distort easily.

Some manufacturers have been known to try to cut back on the time or materials allowed for jig design and manufacture. This is always an expensive mistake. If the jigs are not right, the car body won't be right either. It is a sobering thought that, in the last 30 years, every new tube train London Underground has had delivered has not fitted into the tunnels. One fleet had to be rebuilt.

Tools are another important item which can be forgotten. If any specialist tools are required like dies for stamping steel parts, these must be properly designed and manufactured to the highest standards. Specialist tool makers are best for the job. I have seen shop floors littered with rejected stampings and pressings, thrown out because they were poorly made with bad tools and therefore didn't fit were they were supposed to.

2.15.7. Manufacturing Engineering

The early design meetings will culminate when the scheduling department produces a Work Breakdown Structure (WBS), which will map out how the vehicle will go through each stage of manufacture and assembly to reach the final steps where it is commissioned and delivered to the eagerly awaiting customer. The WBS will have to match a time plan, the submission of which is invariably part of a contract these days, and which will contain milestones in the design and manufacturing process which the supplier must adhere to. It will also provide convenient packages for the design staff to work within so that drawings for the production process can be issued quickly for the first parts needed for assembly.

If the DO has been lucky, they will find that they are able to get away with only modifying and updating some existing drawings and perhaps, if they are really lucky, only the drawing number will need to be changed. Of course, life is never that simple and there will be panics and much heart searching as new designs have to be developed in the time frame agreed with the customer and with the production control people in the factory.

2.15.8. Configuration Control

Once the DO finishes a package (a complete set of drawings for a specific item of manufacture), it is forwarded by a Configuration Control section to the manufacturing engineering department. Configuration control is responsible for ensuring that all the drawings and documents connected with the contract are registered, submitted to the

customer for approval, returned from the customer in time (they are often not), questions from the customer are answered, that the latest updates to drawings and instructions are passed to the production control people and all correspondence is noted and archived. It may sound bureaucratic but it is essential if all the paper is to be kept up to date and is retrievable if there is any sort of dispute (and yes, there always is).

Configuration control is also about monitoring the putting together of the vehicle as it gets built ensuring not just that there are no parts missing but that all the parts fitted are at the correct modification state, both hardware and software (see [Version 25](#) story on this site). The former is difficult because of the slow rate at which hardware faults always seem to get corrected and the latter is even more difficult because of the sheer speed at which programmers empirically try to debug their products, with sometimes chaotic results.

Now the challenge comes: the DO has completed a design package and it is manufacturing engineering's turn to look at what has been produced to see if it can be made. Manufacturing engineering is usually part of a team under the Project Manager who will be ensuring the vehicle is 'coming together', so to speak, and will also include a couple of engineers and draughters to make any changes that are needed. Sometimes it is necessary for the manufacturing department to produce additional drawings that will enable the manufacture to continue without delay. These will be produced in conjunction with the production department.

2.15.9. Production Control

Production control have the responsibility of bringing all the various procurement and manufacturing areas together and ensuring a completed vehicle comes out of the shop with all the requirements of the customer to the schedule agreed with the customer. To do this, using the BoM we talked about earlier, a schedule will be put together which will show what tasks are to be completed, where, using which machines or tools, when and by whom, in the manufacture of the vehicle. This will show the various work stations, identifying the tasks that will be performed at each station. Production control will also allocate materials, staff and times for each process. Production orders are then produced and passed to the manufacturing shops together with the drawings.

2.15.10. Materials & Equipment Buying

There are all sorts of fancy names for "buying" around nowadays; Purchasing, Procurement, Sourcing, Materials Management and so on, but when it comes down to it, buying is what this department does. A manufacturer usually has one buying department which may be split into two sections one to buy raw materials, the other to buy complete items of equipment.

The section buying the raw materials will get their orders from the manufacturing department and will be involved in the purchase of bar stock, sheet plate, nuts, bolts, piping, paint and probably such items as welding rods, glues and mastics. Their responsibility will be to ensure sufficient material is available in the machine shops, the fabricating shop or the paint shop to enable parts to be finished to schedule. They have to do this early in the process. We have already seen how some specifications for long lead items will have been agreed and ordered immediately after NTP.

The section buying equipment will, for the most part, have a more difficult job and they will deal mainly with the DO. This is because they will be reliant on the DO providing technical specifications to issue to the various sub-suppliers. Sometimes the customer's specification will dictate whose equipment should be used. This makes it very difficult for the buyer to obtain a competitive price, as the sub-supplier will be aware that their equipment is specified by the customer. In any case, the buyer will be under pressure from the DO to identify a supplier to enable designs to be completed and he can become caught in a vicious circle if he is waiting for the specification from another group within the DO.

Finding three suppliers of say, a braking system, can be a difficult task and, if it is a boom time for orders and the brake manufacturer has a full order book, getting his attention will compound the problem. But the buyer has to find the right product at the right price, so he will find himself in endless discussions and meetings with the salesmen and engineering staff of the supplier. The DO staff will want to meet with the engineers from the supplier to learn about the physical and performance capabilities of the equipment and the buyer will be expected to attend these meetings to make sure the DO does not 'gild the lily' with the product and increase the price out of range of the budget.

2.15.11. Parts Manufacture

The many parts that make up a locomotive or car body shell will be made in a machine shop(s) either at the manufacturer's plant or contracted out to sub-suppliers. These parts may be structural members, ribs, bolsters or panels. It is important that the DO designs parts in such a way that they are easy to make and of materials which can be processed by the factory with its existing equipment. It is also important that the parts can be easily assembled to form the vehicle as it progresses through the manufacturing process. The cost of many vehicles has soared because the design of parts has caused trouble for the assembly process by being too complex, too tight tolerances, or too difficult to handle. Curved shapes are the worst and roofing the most vulnerable to such problems.

2.15.12. Underframe

Once sufficient parts have been manufactured separately, they are finally brought together for assembly in a jig. The underframe is usually the first part of the bodyshell to be built and its principle parts will include, sole bars, runners, bolsters, and transoms.

An important feature of the manufacture of the underframe is the provision of a camber. This is the 'bowing' of the frame along the longitudinal length upward from the ends to the centre. The camber is important because, as all the other structures are added to the underframe, the weight obviously increases. If there was no camber, the resulting car shell would sag in the middle. To see how this works, look at the trailer of an articulated truck that you see on the road and observe the upward bow.

The vehicle underframe will be moved through a series of jigs designed to hold the frame in specific locations to accomplish attachment of the various components. See the following photos for the various steps in assembly.



Underframe assembly jig, where all the parts are laid out and welded into place.

Underframe assembly jig, where all the parts are laid out and welded into place.



Underframe inverted in assembly jig where the bolsters are added and camber will be introduced.

Underframe inverted in assembly jig where the bolsters are added and camber will be introduced.



For the next steps it is still inverted but more sections are to be welded in place.

For the next steps it is still inverted but more sections are to be welded in place.



Completed underframe, still inverted where the buffing structure is added

Completed underframe, still inverted where the buffing structure is added



The underframe has been turned to its normal position and the car end has been welded on.

The underframe has been turned to its normal position and the car end has been welded on.



Underframe in rotating jig with car end welded on.

Underframe in rotating jig with car end welded on



Underframe and car end completed.

Completed underframe end welded on

2.15.13. Sides

Similarly to the underframe, the various parts of the vehicle side will be brought together in a series of jigs for assembly and welding. If it is a car body that is being manufactured, the windows can either be cut out of the bodyside panels or the sides will be assembled in sections with the window frames (called pans) already installed. The photo below shows a bodyside assembly jig with steel in place for welding.



Bodyside assembly jig. It is shaped to match the body curvature. The panels and their internal strengthening members are held in place by clamps while being welded.

Bodyside assembly jig

The most difficult aspect of side manufacture is getting an acceptable degree of flatness whilst keeping the weight of the bodyside within reasonable bounds. Welding the panels to the frame often causes rippling of the panel due to distortion by the heating of the welding process. Clamping the skin under tension can help but post welding straightening is often necessary.

2.15.14. Bodyside Assembly

Once the various parts are completed - underframe, bodyside and roof they are brought together in a jig for final welding. This jig will align the assembly and clamp it in place securely in anticipation of welding.



Bodyside ready for transfer to bodyshell assembly jig.

Bodyside ready for transfer to bodyshell assembly jig.

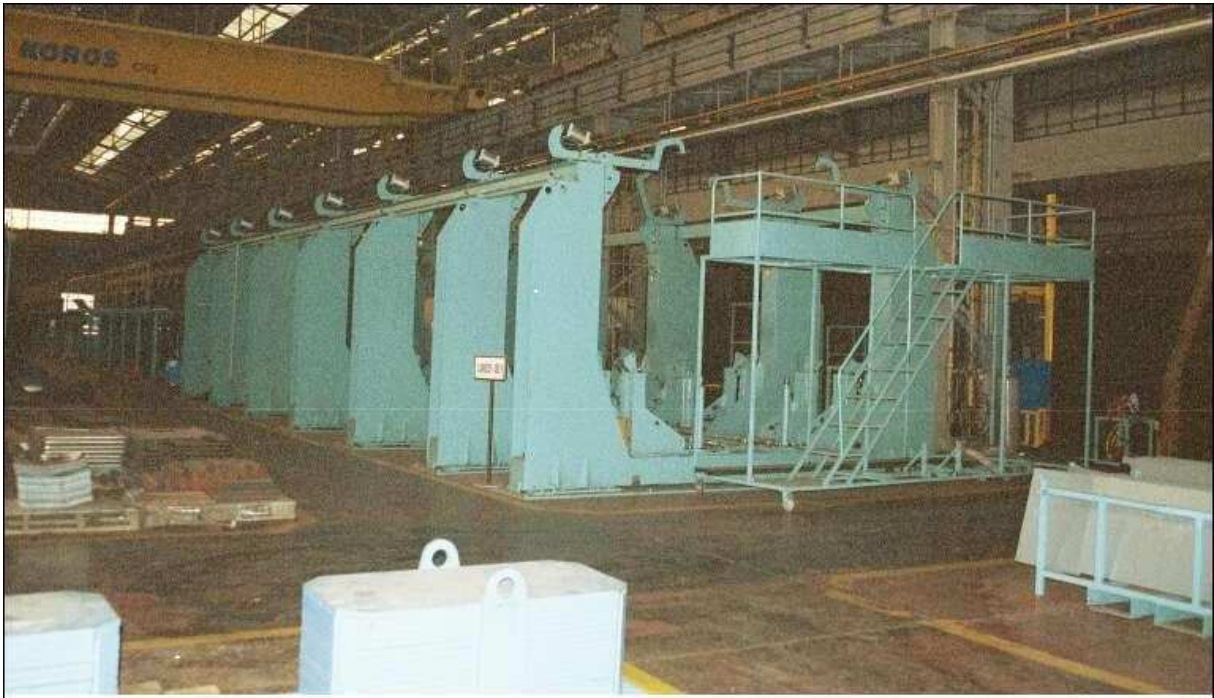

Bodyshell assembly jig.

Bodyshell assembly jig



Body inside another assembly jig.

When the welding is finished, the completed shell is moved to an inspection and straightening jig. This is where it can get interesting, watching the craftsmen using their skills to straighten the sides. As we have seen, the sides will usually show ripples on the skin due to the tolerance generated during assembly and the expansive effects of welding. At the same time, grinding of the welds will take place to smooth any rough edges.

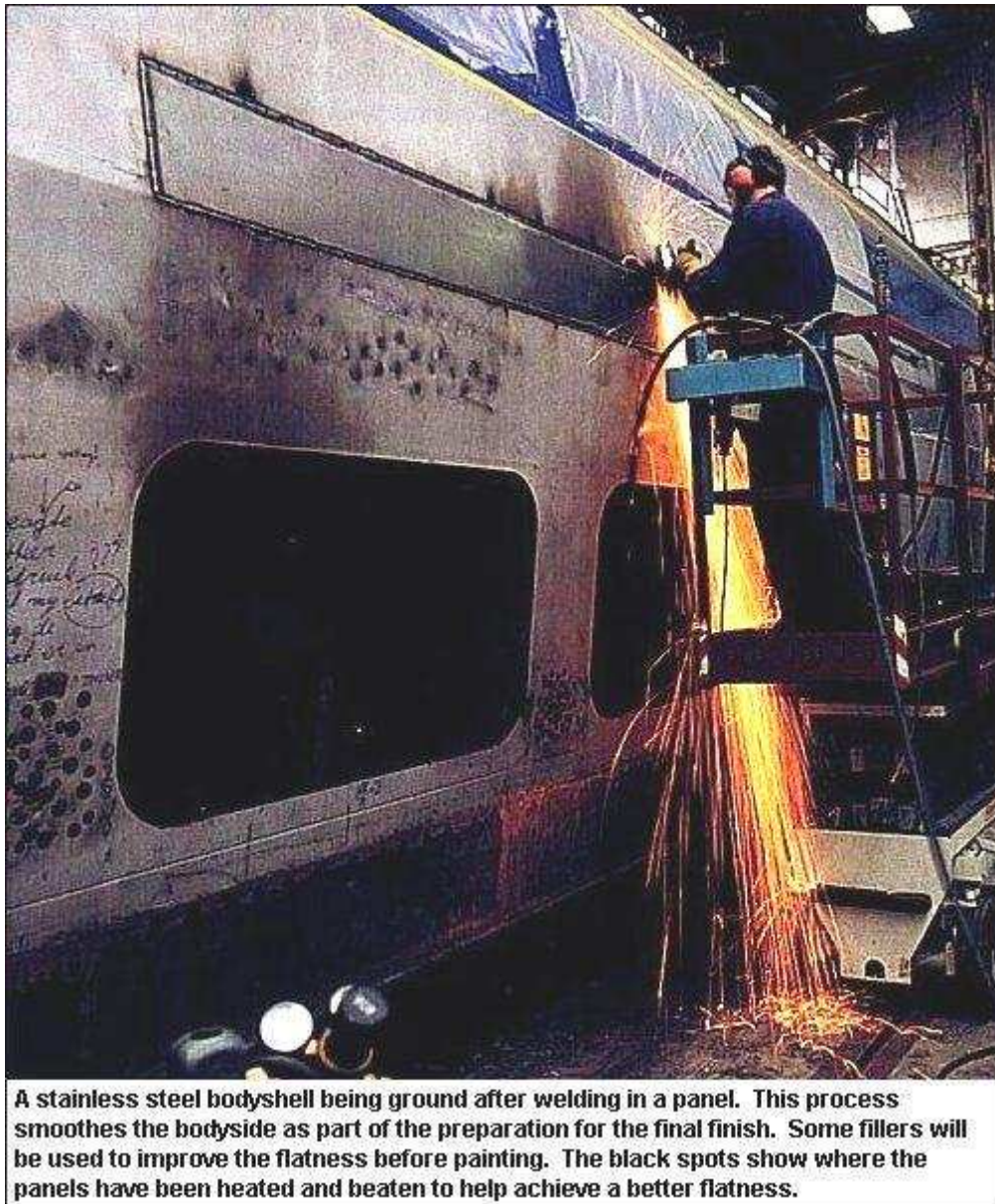

Grinding a bodyshell

Straightening may involve using a large hammer with a blow torch to heat the skin (heat and beat), or it may employ a more sophisticated method such as attaching a magnetic panel (contoured to suit the shape of the body) to the outside of the skin and a thick panel to the inside, using the magnet as shown below. This 'thick' panel will have a series of equally spaced holes through which heat is applied using a multi-nozzle blow torch. The heat applied has the effect of stretching the skin of the body, due to the spot heating, causing the panels to straighten. Vacuum clamping is also sometimes used.



Body-side straightening magnet.

Body-side straightening magnet



Bodyside straightening panels for use with magnet.

Bodyside straightening panels for use with magnet



Heat treated bodyside panel.

Heat treated bodyside panel

It will be dependent on whether the car has a stainless steel or low alloy, high tensile steel body as to the method used for straightening. It is virtually impossible to straighten a car body which is required to have an unpainted stainless steel finish.

In one respect, aluminium is a better material to use for car body assembly. It is light enough that it can be supplied in thicker sheets, which don't buckle during assembly. The straightening process is therefore eliminated. However, it is more expensive than stainless steel and has a lower strength.



Aluminium car end framing

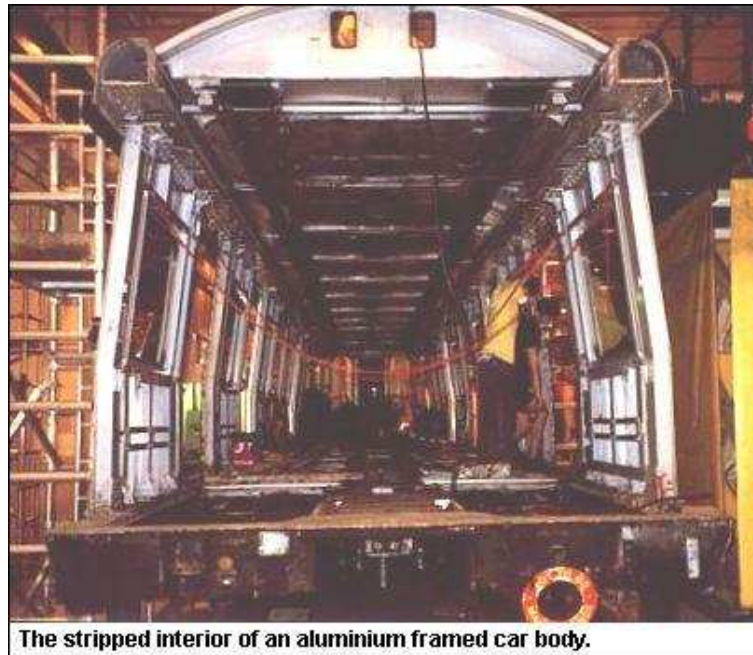

Aluminium car bodyshell

Traditionally, aluminium bodies were rivetted (above) but nowadays, a popular form of aluminium design is extrusions welded together to form a structure.

2.15.15. Underframe Invert

In the underframe manufacturing photos above, the underframe is shown being turned over or inverted at several stages during its manufacture. As we have seen, when the underframe, sides, ends and roof are completed they are brought together and assembled to form the bodyshell before fitting out. However, this is only one way of assembling a car body. Some vehicles are assembled by bolting sides, ends, roof and floor together. This system has been successfully used in the UK in recent years.

The underframe will eventually carry all sorts of equipment. Various brackets, pipes and cable runs need to be attached and, to fit them from underneath is a backbreaking and slow task. To make it easier, once the underframe is substantially complete and before it has the car sides and ends attached, it is inverted again. This task is usually performed using a crane and, once it is turned over, the extra brackets are welded on and pipes, conduit and air reservoirs bolted or welded on. The technique has been used for many years in some plants overseas.

2.15.16. Roof

For a mechanically fastened body, the roof goes through much the same process as the underframe or sides. Although there will probably be less items involved than say the underframe, the curved shape of the roof will require a jig to form the contour. This will be complicated if it is a ribbed section and will probably need holes cut out to accommodate vents, HVAC and ducting. The first roof is always difficult to assemble,

since the jig has to be just right as well as all the parts making up the roof itself. Once assembled, a roof for a passenger car may be inverted for the fitting of ducting and wiring.

2.15.17. Ends

The modern train will often be designed to have an aerodynamically smooth front end. However, certain crashworthiness standards are necessary, so some protective structure will be needed as well. The usual solution is to construct a steel framework (see photo, below left) and then mount the smooth, shaped end over it. To achieve the three dimensional curved shape in steel or aluminium is difficult - although the Germans seem to have done it (doubtless at great expense) in their high speed ICE trains so most manufacturers often use a glass reinforced plastic (GRP) moulding. There are normally made by specialist producers, since the process requires skill, special materials, proper environmental protection systems and careful quality control.



Leading end of TGV power car showing the massive steel end structure.

2.15.18. Painting

For some years after World War II, it became fashionable to produce car bodies without painting them. This saves labour and weight and seemed, at the time, to have an acceptable finish. When graffiti began to appear in the US in the late 1970s and in

Europe in the early 1980s, it was found that the unpainted bodies were very difficult to keep clean. Attempts to remove the graffiti paint left ingrained marks. Often car bodies became severely damaged (see [A New York City Car History](#) on this site). In some cases, the cars have been painted to try to improve the appearance. The paint used is a special two-pack mixture which is supposed to harden to a graffiti resistant finish. Nowadays, painting for trains has become the norm again and some interesting colour schemes have resulted. A car builder will need to have a fully equipped paint shop and drying facility, together with all the necessary fume extraction and fire protection equipment.

Most manufacturers use a body filler on the outside of the vehicle body prior to painting to present a nice smooth finish to a painted bodyside (see photo below) but buyers need to ensure that a good quality filler is used when accepting this method of finish, as problems can occur further along the life of the train if the filler starts to crack and fall off and water gets in, causing rusting.

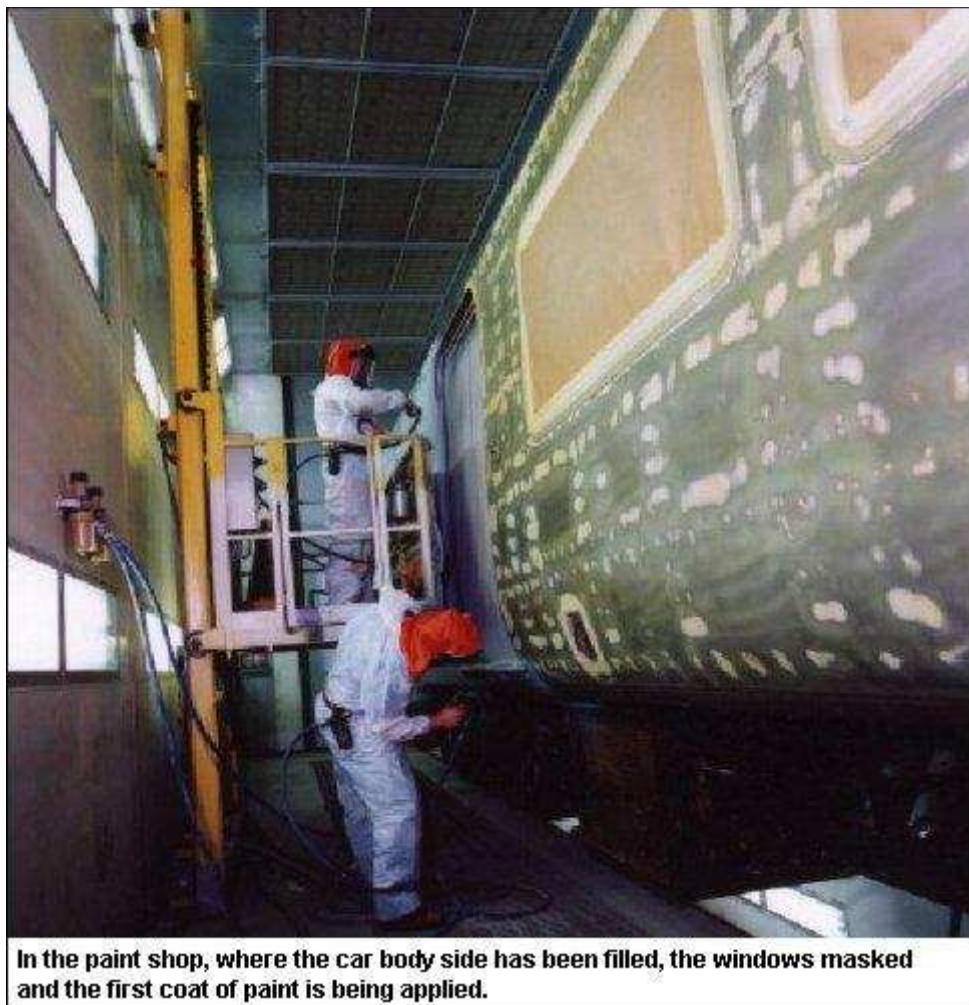

Car body in the paint shop

2.15.19. Transport

An important part of the manufacturing process is how to move things around the works. Modern railway vehicles contain long sections of lightweight materials which, for example, need to be moved from the rolling mill to the welding jig. A 24 metre long steel section needs careful handling if it is not to be ruined by accidental bending while being swung from one side of the shop to the other.

It is worth mentioning here that a railway vehicle factory can be a very large place. If you say that a site requires one square kilometre of land, you would be in the right ball park - well, a very big ball park. This means that you have to move things around during manufacture. Very often, large parts, like underframes and roofs are made on jigs in a large shop and moved through assembly jigs to a final assembly jig. Moving a stainless steel roof 24 metres (65 ft) long is difficult because the roof will flex. Secure cradles need to be designed to protect parts which have to be lifted or moved from one area to another. Cranes will be required in all the shops. In the two photos above, the car roof is being manoeuvred in a large frame to prevent distortion. Overhead bridge cranes are the traditional type used for the larger items like this and a big shop will need at least two.

Another problem area is fixing bolts protruding from items shipped into the factory from a subsupplier. These will be damaged if not properly protected and handled.

2.15.20. Bogie Construction

Bogies run from the very simple cast steel design (such as the traditional US three-piece freight bogie which is basically a pair of side frames and a bolster see [Vehicle Suspension Systems](#) on this site) to very complicated fabricated designs with steel spring primary suspension, air bag secondary suspensions and both tread brakes and discs (such as French TGV bogies). Many decisions have to be taken in selecting the bogie appropriate for the role. Besides the suspension system and brakes, it is necessary to decide whether to use inside or outside bearings, solid or hollow axles, and to choose the wheel diameter and tread profile. (See the [Bogie Page](#) on this site for an explanation of the various parts that make up a bogie)

For now, we will concentrate on the fabricated passenger vehicle bogie to explain the manufacturing process. The various parts that make up the side frames are assembled in a rotating jig and welded together and then moved to a new jig where the bolster or transom, depending on the type of bogie, will be welded in place.



Bogie frame after welding and before painting. The white marks are dye penetrant for non-destructive testing.

Bogie frame after welding and before painting. The white marks are dye penetrant for non-destructive testing.



Trailer bogie for Korean TGV high speed train. The large suspension units support the articulation between the two adjacent car bodies. Note the provision of 4 large braking discs on the axle to cope with braking from high speeds.

Completed TGV trailer bogie with large suspension units for supporting the articulated car ends.

It is very important to have the "tram" of the bogie correct - this is the diagonal measurements taken from corner to corner - and special measuring equipment will be used to ensure the bogie frame is within tolerance before final welding takes place. Once the frame is manufactured, it is painted and then the externally mounted parts will be added.

2.15.21. Wheels and Axles

Normally, wheels and axles are bought as completed items and only need a minimal amount of machining work for assembly. The wheels will need to have the centres bored to suit the axle end diameter. This will be carried out on a wheel boring machine, which is a very big vertical borer with the wheel held in a large chuck. Once this task is complete, the wheel is taken to a wheel and axle press. This is a large horizontal press where the various items that make up the wheel and axle assembly will be pressed onto the axle.



Borer.

Borer



Wheel and axle press.

Besides the wheels, there may be brake disc centres, inside or outside bearings and gear wheels. Each of these items will be pressed on in turn. The fit is an "interference fit" and often there is an oil plug in the wheel to allow the injection of oil to assist in the pressing process. The oil is injected between the wheel and the axle to lubricate the mating surfaces during the pressing process.

Not really applicable to this description but included for interest is that for removal of wheels there is often an oil plug in the wheel to allow the injection of oil to assist in the demounting process. The oil is injected between the wheel and the axle to lubricate the mating surfaces during the removal process.

During assembly, records will be kept of the pressing process just in case there is a problem with the wheelset in the future. It is important during this stage to maintain the correct dimensions for the 'back-to-back' gauge. This is the measurement between the back face of the wheel flanges and it is necessary to ensure the correct fit is achieved otherwise there would be serious and embarrassing consequences when the completed vehicle is placed on the track.

After pressing, the wheelset is transferred to a portal lathe where the wheel treads will be machined to ensure consistency of diameter between the two wheels (see pictures of the various pieces of equipment mentioned). This does not apply to all assembly processes and will be dependant on the type of vehicle being manufactured. It is,

however, very important on vehicles that use a mono-motor bogie design where high torque can occur on curves due to mis-matched wheel diameters.

2.15.22. Bogie Assembly

Bogie assembly now begins in earnest and the parts similar to those shown on the [Bogie Page](#), but applicable to our bogie will be assembled. If the suspension has chevrons, these will be the first items to be connected, if the suspension is using coil springs then that will be one of the last steps as the wheelsets are added. Next comes the air pipes, followed by the brake rigging, then the wiring and finally the wheelsets, culminating with the completed bogie undergoing a load test, (see picture), which will ensure that the suspension is installed correctly and the bogie is functioning as designed.



Bogie load tester

The steps described above could be in a different order depending on which item makes logical sense in the sequence, or to the particular bogie manufacturer's preference.

If the bogies have electric motors and gears fitted, it is important to get the parts fitted with the correct tolerances. It takes a high degree of skill to set up the traction gearing

when fitting a motor so that there is not too much or too little "give" between the gear teeth. This is referred to as a "backlash test".

2.15.23. Wiring

There can be a considerable amount of wire in a rail vehicle and it is important to ensure that the wires are all running from point to point along the most economical route. At the same time, to make life easier for the maintenance department, all wires should run as close together as possible. The only exception to this is that high voltage wiring will be kept away from communications wiring or safety sensitive cables. Wiring is assembled in looms off of the vehicle; in fact, very often, wiring looms are a contracted out item. On modern rolling stock where more consideration has gone into the maintainability of the vehicle, a cable tray arrangement will be used to run the length of the vehicle with arms extended out at convenient locations along the main tray (see the picture below). The wires will be colour coded and/or numbered at regular spacing along the loom, or tray, to ensure the wire is identifiable for connection during assembly or replacement during the life of the vehicle.



A set of cable trays ready for fitting

2.15.24. Piping

Similarly to the wiring there can be a considerable amount of piping on a vehicle and it can be advantageous to assemble some of the runs of the piping away from the vehicle. This will be performed in the pipe shop (where else?), where the lengths of pipe will be cut, threaded on the ends and connectors applied to suit, maybe with a few off-shoots

(branches), as required. These will then be delivered to vehicles for installation, either during underframe invert or in the fitting out shop.

2.15.25. Fitting Out

Once the body shell is complete, our vehicle is sent to another shop for fitting out. In steam locomotive days, this was known as the "Erecting Shop" and there are still some workshops where the name has stuck. It may pay a visit to the paint shop first or, as is increasingly common, some of the bodysell parts may have been painted before assembly depending on the method, of course. Here are some photos of the early stages of the fitting out process, followed by a description of the main steps.



Underside of TGV car showing cable bundles fastened to the body with tie wraps. These are assembled elsewhere and are pulled through on the car.

Cable looms attached to underside of car

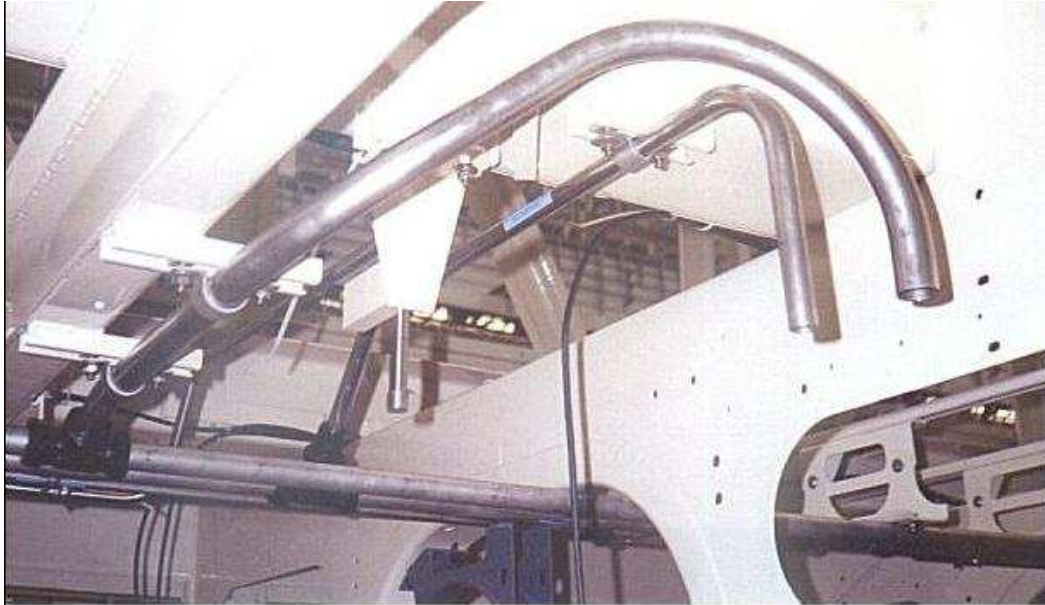

Undercar piping. Piping is normally prepared away from the car fitting area and is then brought to the car and added at an early stage in the fitting process. Some manufacturers fit piping to the underframe before the body shell is assembled.

Piping attached to underside of car



TGV power car awaiting the fitting of air reservoirs for the braking system. One has already been fitted while the remainder are lined up on the shop floor, ready for mounting.

Air reservoirs ready for fitting under car



Interior of TGV trailer. On the car wall between the windows you can see large oval brass coloured inserts. These seal the area after the sound deadening material has been added. At the base of the windows is a jig that is used to protect the car shell during the installation of the window frame. In the right foreground is the wooden jig that holds the floor level HVAC ducting in place ready for fixation. Some of the sound deadener can be seen in the rear and car ceiling.

Interior ducting and insulation



Interior of TGV trailer showing the jigs used to support the luggage racks during fitting. Note also the sound deadening material in the walls and ceiling.

The use of jigs for interior fitting out



Material storage system

You could say it is starting to get interesting now. At last our vehicle will start to look like a piece of rolling stock. While it is in the fitting out area, it will move from station to station to receive the various fittings that make it a complete vehicle. Of course, not all manufacturers follow the same format for assembly but the following description is a typical method for final assembly of a vehicle. Equipment may not necessarily be installed in this order, although you will observe there is a fairly logical progression.

Bodyshells will line the shop sides running longitudinally through the shop. In the first station area there will be an opportunity to weld on the secondary structures (mostly brackets) that the DO has found necessary but did not have sufficient information available when completing the design to include during manufacture in the bodyshell shop. Secondary structure is used to attach interior equipment panels or the body linings. At this stage, any interior insulation to go into the walls, roof or floor will be installed along with any hidden wiring or piping. It is also a good time to hang the doors and door gear as there is minimal other equipment around to interfere with the installation. Whilst this is going on inside, underfloor equipment can be welded or bolted on below the bodyshell, unless the "invert" method of assembly has been adopted. Dependant on what type of vehicle is being manufactured, this stage will include battery

boxes, low voltage power supplies, chemical toilet retention tanks, brake resistors, HVAC and brake equipment, to list but a few.



Ceiling insulation behind the fittings for lighting tubes and air conditioning ducting.

Installation of insulation



Flooring laid inside the coach and over the air ducts along the bodysides to provide continuity and easy cleaning.

Flooring



The installation of a window blind inside the coach

Window blind



Seats being installed inside coach body.

Seat fitting



Sliding plug door for TGV Korea coach.

Door mounting



Reading lights, toilets and parcel shelves being added to the bodyshell of a passenger coach

Interior fittings

At the second station, wiring will commence in earnest with the installation of control cubicles and electrical boxes and possibly the driver's compartment equipment and lighting. Moving on, we will next see the installation of windows, gangway connections, interior panels and flooring (which may be a vinyl or carpeting). From now on, care has to be taken not to dirty the interior, so protective covering will be installed. At this point, handrails and maybe the seats will be installed. If the HVAC unit is roof mounted, this may now be craned in and installed. If we now have everything complete, we may now install our roof lining. Outside, the coupler will be installed and our piece of rolling stock is almost complete.

Now we are nearing the end and the car will be lifted on to its bogies and electrical and mechanical connections made. At this point, there will be a final check through the vehicle and clean out remaining debris. Once this is done, the vehicle is handed over to the testing department to complete all the integration tests described below.

Final cleaning and removal of protective covers will not take place until all the testing, and probably the commissioning, has been completed. Too early removal of protective covers leads to possible claims from the customer for scuffing or ingrained dirt and subsequent costly rectification by the manufacturer.

Assembly Methods Lift or Roll?

Two different systems are used for vehicle fitting out. The older system has each unit in production standing in a fixed place with the equipment brought to it until all is installed. When all work and some basic testing is done, the unit is lifted up and over the other vehicles to where it will be landed on its bogies. Its bogies are "plumbed in" and it is then towed out to a test bay for the required verification tests. The space left by its lift is filled by another body shell unit which go through the same process until fully fitted out.



TGV Car bodies being moved around the KOROS workshop in South Korea.

The other system adopts the rolling production line system, where each unit is passed through the shop in a set sequence, beginning at the entrance to the shop and finishing at the exit as we saw above. Sometimes, two or three lines might be created, so that a unit will pass down the shop on the first line, back up on the second and down again on the third. The advantage of this system is that all vehicles must be kept on the move to ensure production continues smoothly. If a problem arises, it must be fixed quickly, otherwise the whole production line is delayed. It encourages people to get things done. However, it may make people rush and it does require strict quality control, otherwise, units show up a lot of problems during testing and a whole team has to be kept in the test bay doing rectification work.

The static method solves these problems but it can lead to a unit with a problem staying in the shop long after it is due to leave. People tend to get on with other things and leave

the difficult one waiting for a spare part. This system also requires a workshop with sufficient height clearance to allow a complete vehicle to be lifted over the others in the shop. Nowadays, the production line method is the more popular.

Locomotive Assembly

The assembly process described above relates to multiple unit passenger trains. Locomotives are somewhat different but only as far as the procedure for the installation of equipment. Usually, the diesel engine, alternators, inverter units, blowers, compressors and other large items are lowered through the roof of the locomotive. This means that the roof will be one of the last items to be fitted. It is often arranged to be mounted in sections so that it can easily be removed for maintenance access.

2.15.26. Testing

It is fairly obvious that, once the train starts coming together, testing will start but, in reality, it starts a lot earlier in the manufacturing process. An example is the the combined test, where the propulsion kit is all laid out on the lab floor, including converters, motors, gearboxes, control system and even the ATP and ATO. The motors sink into dynamometers (see [Booster](#) story on this site) which can also be set to motor, ie to simulate the kinetic energy of the train during downhill running or braking. The dynamometer excitation is controlled by a computer that is programmed to simulate the real load cycle of the railway on which the train will be used, though in the case of the Docklands Light Railway (London) traction equipment combined test at Preston, there was a range of "site data" available, from the Sishen-Sadhana ore line to the TGV SudOuest! Alstom went even further on the Eurostar, when they set up a whole train's worth of "informatique".

The obvious advantage of combined test is that a lot of the interface and software debugging is done long before the train starts to appear on the shop floor. The "informatique" and propulsion hardware is less of a long lead item than the rest, yet the debugging can be even even more painful than getting a Stanier "Jubilee" to steam freely. And, even if motors and gearboxes take longer to arrive than the propulsion cases, the latter can drive into dummy loads for the time being.

Before a unit of rolling stock is accepted by the customer, there will be many formal tests to be performed. Each piece of equipment will be tested, before assembly into the train, first at the particular subcontractor's plant. This is usually referred to as a First Article Inspection (FAI) and will involve an inspector comparing the specification and drawings to the actual product in front of him. In the majority of cases, the piece of equipment will receive some form of dynamic test. This, for instance, could involve operating a gearbox

on a test rig to verify it works correctly or maintains the correct temperature for the oil. If it is an electrical/electronic item, tests for continuity or breaker tripping and so on will be performed.

Once all the FAI tests have been completed and passed as satisfactory on a particular item, the equipment can be sent to the vehicle builder for installation. When the rolling stock has been assembled, another series of tests will verify that the equipment functions as intended. There are both dynamic and static tests. Static tests will be used to verify such areas as the EMI (electro-magnetic interference) emissions or Hi-Pot testing or could be as mundane as testing the functioning of the lights or the raising and lowering of a pantograph. Some tests will seem mundane and will just be proving that lights work or the windshield wipers are working. Others have a more important function and will ensure that the wiring is correct through the vehicle or trainset, called trainline testing. If we are testing the cab controls then the power lever and the braking will be tested along with forward and reverse. All the warning and information lights will be checked for correct operation. Back in the vehicle tests will be carried out to prove the HVAC system is functioning correctly and heating and cooling as it is supposed to do. Also, if power is lost from the main supply, a test will ensure that the emergency back-up battery works and that power load is reduced by shedding over a set period of time to reduce the load requirement and, hence, current draw on the battery. Every piece of equipment will be tested on each piece of rolling stock and witnessed and approved by an Inspector appointed by the customer, before the rolling stock moves onto the next segment of the acceptance cycle, which is commissioning.

2.15.27. Commissioning

All the tests have been completed and approved and now comes the interesting part, where the rolling stock is commissioned, usually on the customer's property. If it is a new piece of rolling stock or a trainset there will be a set of tests required called a performance evaluation. These tests will be used by the supplier to prove to the customer that what he is getting is, in fact, what he ordered. When the order was first placed, probably the first one or two items of rolling stock (or trainsets) would have been designated as prototypes or pre-production units. The intent here is to prove everything is in order before the supplier commences production of the remainder of the fleet.

Commissioning tests will prove that all the pieces of equipment the supplier has purchased from the multitude of sub-suppliers have been integrated correctly and 'talk' to each other. It is obviously important that when the train driver issues a command, through his master controller, say to slow down, that the brakes apply and at the same time the propulsion system is not trying to accelerate the train. Oh yes, it has happened!

Dynamic tests will be used to prove the acceleration and deceleration tests meet the specification performance criteria. Some contracts include an endurance or "burn-in" test when the vehicle will be tested and required to achieve a number of kilometres without a failure. If a failure occurs in this time the clock is stopped and the testing starts all over again. This arrangement is popular in the US.

2.15.28. Delivery

Delivery (in a contractual sense) occurs in two stages at two defined times. The first time occurs when the rolling stock is 'pushed out gate' which means, if the supplier is delivering by rail, pushing the train through the gate separating their property from the railway's. Nowadays, most deliveries occur by road, as manufacturers have such diverse customers, not just in their own country but around the world. Prior to this there is usually a ceremony where the manufacturer will hand over a key (for the master controller) or some significant symbol to the customer noting the delivery of the first item of his order. As each vehicle or train is shipped out and signed for by the customer, the contract has reached "substantial completion" for this unit.

Vehicles being shipped by road or sea (even by air sometimes), need to be packed properly. It is usual to ship bodies and bogies separately. If the shipping involves a sea passage, careful protection is required for the body and parts vulnerable to damage by seawater or just the salty atmosphere.



Light Rail Vehicles packed into the hold of a ship.

Bogies are packed so that the vibration of the suspension does not create wear. The shipping process invariably involves craneage and it is essential to ensure the docks know how to handle railway vehicles, which are very difficult to load on and off ships without damage.



A TGV high speed vehicle being unloaded from a car ferry ship in Korea. The move from the deck of the ship is a delicate operation carried out using a special trailer and tractors.

TGV Vehicle being unloaded from ferry ship.



A TGV high speed vehicle being moved through the streets to the factory where it will be reunited with its bogies. The vehicle has been lifted off the special trailer used during shipping and placed on to a road trailer as seen here. The route taken by road will have been surveyed to ensure that there are no obstructions like telephone wires and traffic signals which could be damaged. Note that the body corners are supported on jacks to prevent the underframe equipment being damaged by the weight of the car body.

TGV car on low loader being driven through streets.

The above photos show the delivery of TGV vehicles built in France and then shipped to Korea for the new high speed line there. In addition to the difficulties of a sea passage, the vehicles have to be moved from the docks to the railway sometimes a long distance. The route must be surveyed to ensure that there are no obstructions. Often telephone or electricity cables are vulnerable and they are seldom in the places where the authorities think they are. A route plan may show where everything should be but there is no substitute for a thorough visual survey. Of course, permission and assistance will have to be sought from the local police. If traffic conditions require it, moves many have to be made at night.

Once the equipment has arrived on the customer's property, final commissioning takes place. The second delivery stage, mentioned earlier, begins at the end of the commissioning when all tests have been signed as 'passed' and the customer is satisfied that he is getting what he paid for. This delivery usually occurs at the customer's maintenance facility and signifies that the rolling stock is ready for revenue service. Now the warranty clock begins to tick.

2.16. MULTIPLE UNIT OPERATION

2.16.1. Introduction

Originally derived from lift operation over a hundred years ago, multiple unit (MU) control has become the most common form of train control in use around the world today. This page describes how it started and its development in the century to date.

2.16.2. Origins

Electric locomotives were originally designed so that the motors were controlled directly by the driver. The traction power circuits passed through a large controller mounted in the driving cab. A handle was rotated by the driver as necessary to change the switches in the circuit to increase or reduce power as required. This arrangement meant that the driver had to remain close to the motors if long and heavy, power-carrying cables were to be avoided.

While this arrangement worked well enough, the desire to get rapid turnrounds on city streetcar railways led to the adoption of remote control. The idea was that, if the motors could be remotely controlled, a set of driver's controls could be placed at each end of the train. It would not be necessary to have a locomotive added at the rear of an arriving train to allow it to make the return journey. A cab would be installed at each end of the train and the driver just had to change ends to change direction. Once this idea was established, it was realised that the motors could be placed anywhere along the train, with as many or as few as required to provide the performance desired. With this development, more but smaller motors were scattered along the train instead of building a few large motors in a locomotive. This is how the concept of motor cars and trailer cars evolved. Trailer cars are just passenger carrying vehicles but motor cars are passenger carrying vehicles which have motors and their associated control equipment.

Multiple unit trains, as these trains became known, were equipped with control cables called train lines, which connected the driver's controls with the motor controls and power switches on each motor car. The opening and closing of the power switches was achieved by electro-magnetic relays, using principles originally designed for lifts. While the idea was being established on passenger trains, it was also adopted on locomotives. It quickly became the standard method of control.

2.16.3. The Relay

The diagram below shows how a relay operates.

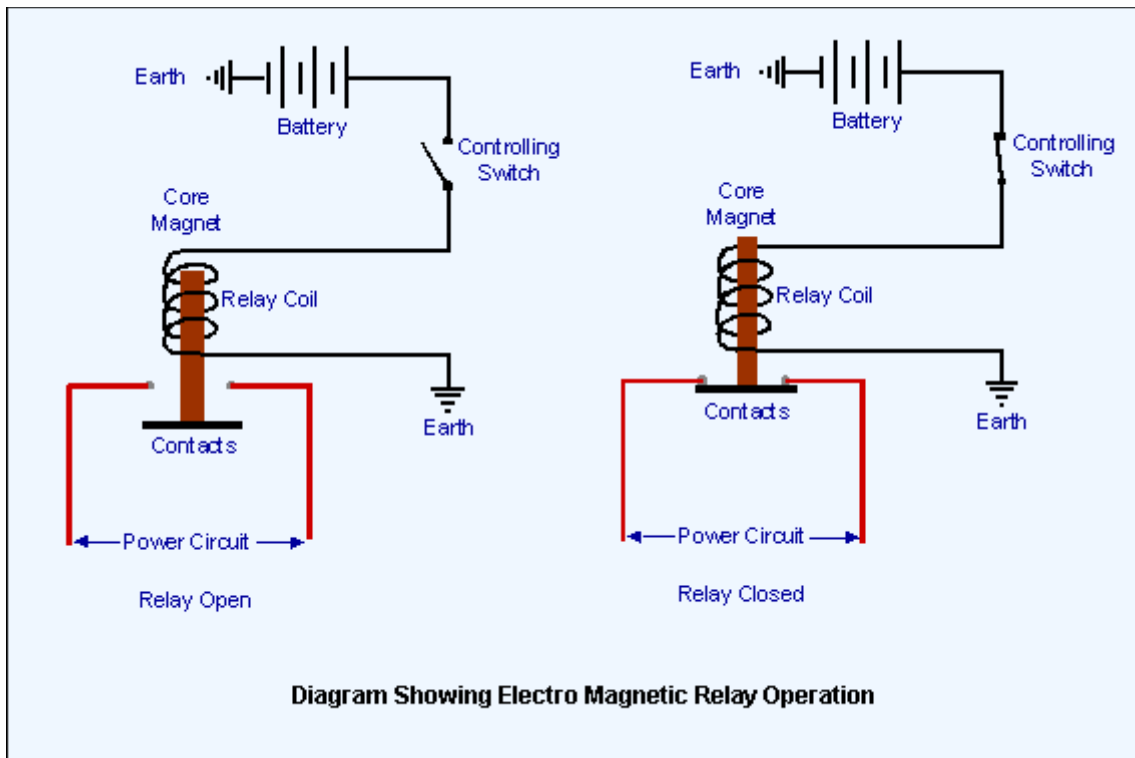

A relay is really a remotely controlled switch. In the diagram left, a power circuit contains a switch which is opened and closed by operation of a relay. The relay is activated by a magnetic core which is energised when a controlling switch is closed. As the core is energised, it lifts and closes a pair of contacts in a second circuit usually a power circuit. The current required for the relay is usually much lower than that used for the power circuit so it can be provided by a battery.

In the diagram, the controlling switch is open, so the relay is de-energised and the power circuit contacts are open. If the controlling switch is closed, as in the right hand diagram, the relay is therefore energised and its core magnet lifts to close the contacts in the power circuit.

Applied to a simple lift operating between two levels, a control switch on each landing could use relays to switch on the lift motor to move the lift up or down. On a train, the controlling switch could be located anywhere on the train to activate the relays controlling the power to the motors. The same principles can be used to carry out any other switching e.g. for lights or heating. It represents a safe and simple way of transmitting commands to a number of equipments in a train and it is the foundation upon which multiple unit control was based. On modern rolling stock, the relay is being

replaced in many applications by electronic control, which speeds operation, eliminates the mechanical movements required and allows the miniaturisation of control systems.

2.16.4. The Contactor

As we have seen from the description above, the relay must have a current applied to it all the time it is required to be closed. To avoid having current on to, say, a lighting control relay all the time, a different type of remotely controlled switch is used. This is called a contactor.

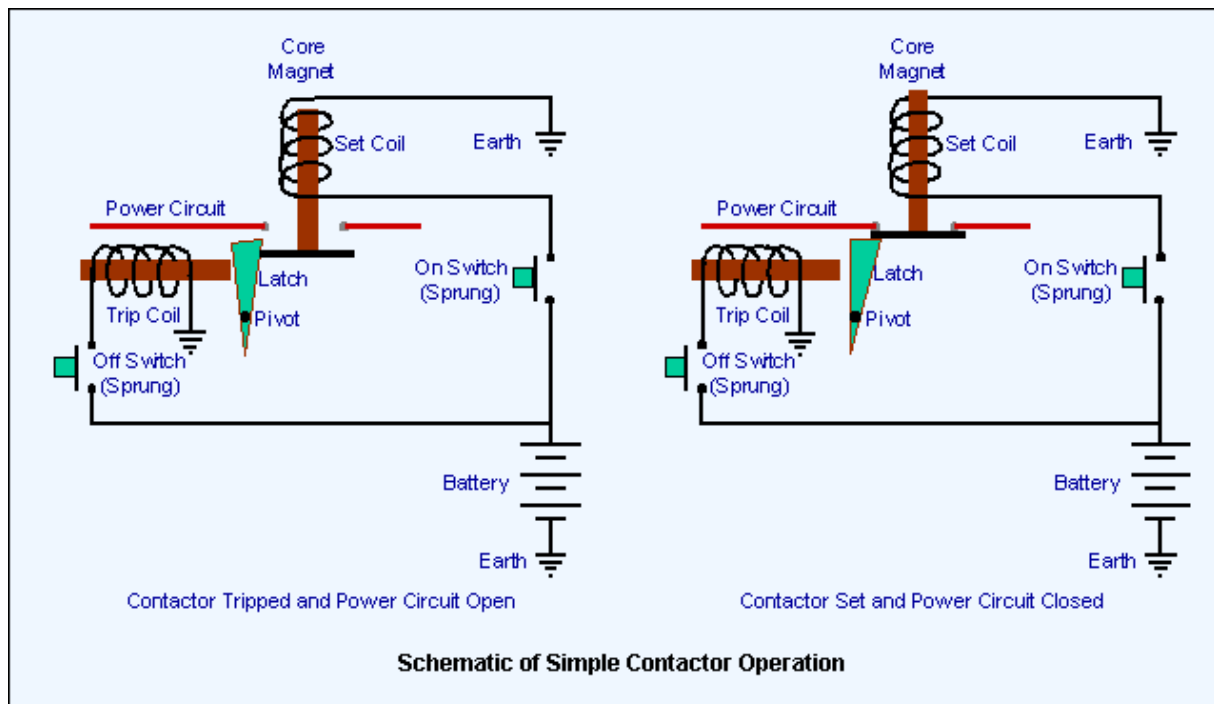

The contactor is really a latched relay. It can also be called (in the US) a "momentary switch". It only requires current to be on for a "moment" for it to operate. In order to keep the contacts closed once the control current is lost, the power circuit contacts are held in position by a mechanical latch. When it is necessary to open the power circuit, the latch is released and the contacts drop open.

The contactor is operated by two coils, each with their own controlling switch. In this case, the contactor is closed or "set" by pressing the ON button and opened, or "tripped" by pressing the OFF button. Both ON and OFF buttons are sprung so that only a momentary current is used to activate the coil.

Contactors are widely used on trains and, for us, are a good example to demonstrate how multiple unit control works in practice.

2.16.5. Multiple Unit Control

The following diagram illustrates the principal of multiple unit (MU) control as applied to a 3-car train.

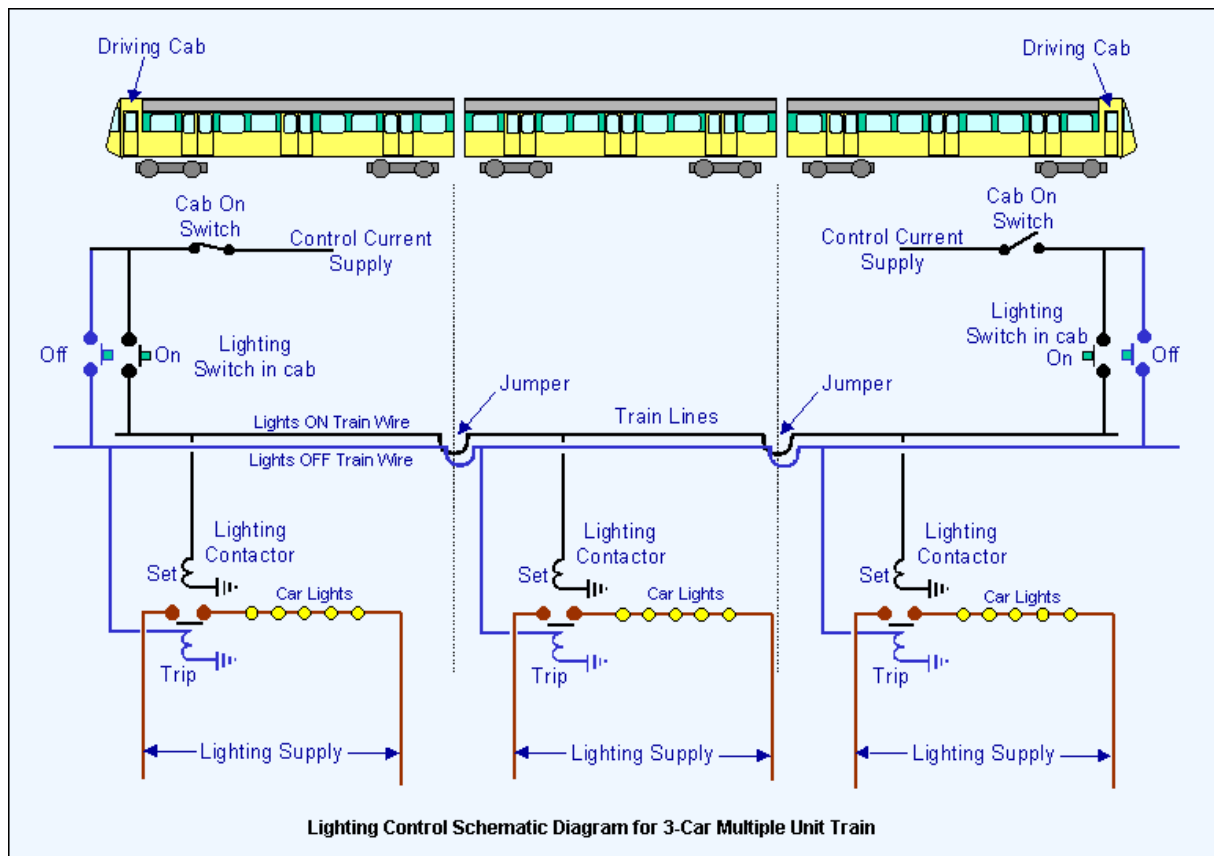

In the diagram (left), the lighting on each car is switched on and off by a lighting contactor. The contactor is latched closed when its "set" coil is energised or opened by the "trip" coil to unlatch it when required to switch off the lighting.

All the lighting contactors on the train are connected to train wires, in this case one for "lights on" (in black) and one for "lights off" (in blue). The ON and OFF buttons are in the driving cabs at each end of the train so, the lighting can be switched on or off from either end of the train

To prevent unauthorised use of the control buttons, most of the important circuits in the cab are isolated by a "control switch" or "cab on switch". This is key operated and keys are only issued to qualified drivers or maintainers. It also means that, in our example, lights can only be switched on or off from one end at a time. The same principle, using contactors or relays, is applied to all other systems on the train driving controls, braking control, heaters, doors, air conditioning, public address etc.

Of course, current for the equipment on each vehicle, as in this case, lighting, comes from a separate source the [auxiliary supplies](#) in the form of a battery, an alternator, an inverter or a power train line.

2.16.6. Forward and Reverse

How, one might ask, does one ensure that a number of locomotives or EMUs (or DMUs for that matter), coupled together to work in multiple, perhaps facing in different directions, will all respond to the driver's command to go in the same direction, say forward, from the cab where he is sitting? How do you prevent one locomotive taking off in the wrong direction? Well, it's built in to the wiring and it's simple, as shown in this diagram.

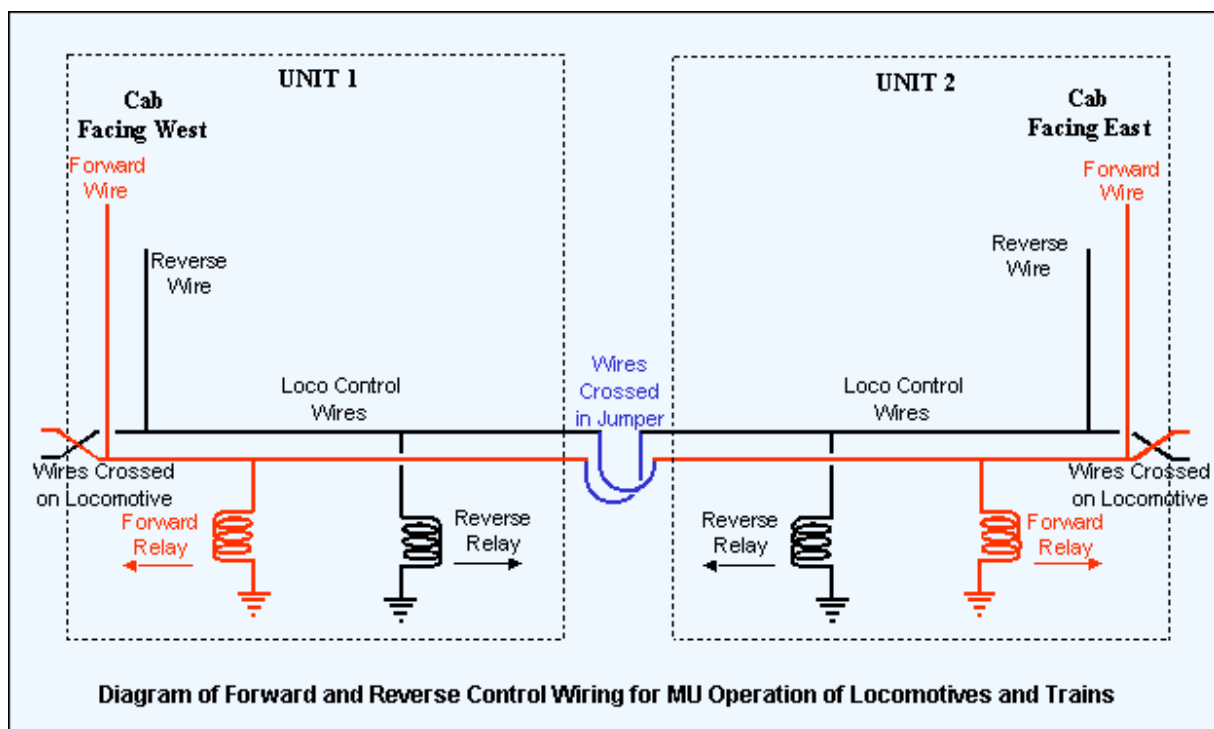

Each power unit (whether it be a locomotive or EMU) has a forward wire and a reverse wire connected to a "Forward and Reverse" switch of one sort or another in the cab. Looking at Unit 1, if the driver selects "Forward", the forward wire (in red) is energised and the "forward relay" (the arrow shows the direction of movement obtained for each relay) is energised to make the locomotive move in the forward direction.

To ensure the correct direction is achieved by a second locomotive (Unit 2) that is coupled to the first, the forward and reverse wires are crossed over in the jumper cable. If the second locomotive faces in the opposite direction to the first, its reverse wire (shown in black here) will be energised to make the loco run in the same direction as its partner. To make sure this always happens, all multiple unit control jumpers have their forward and reverse wires crossed

But, you might ask, what if the locos both face in the same direction? You don't need the crossed wires in the jumper. The crossed wires in the jumper will make the second loco go the opposite way. No, that's been solved too. So that the same jumper with the crossed wires can be used anywhere, the forward and reverse wires are also crossed ON each locomotive, only at one end, usually near the jumper socket. Now, no matter which way round the locos are coupled to each other, and in what order, the forward command will always make all units drive in the same direction and the reverse command will make all units drive in the opposite direction.

One final point. The jumper heads are designed so that they can only be inserted one way into the coupler socket on the locomotive, rather like a mouse plug on a computer.

2.16.7. Modern Control Systems

Modern systems use single wires or even fibre optic cables for controls. The system is sometimes referred to as "multiplexing", where a number of control signals are sent along a single wire. Some administrations require hard wired controls for safety systems like train braking but diverse programming can be used to make this redundant.

2.17. MULTI-DECK TRAINS

2.17.1. Introduction

This page looks at railways which use vehicles with more than one level and show some examples of how they have evolved. Both passenger and freight examples are included, with diagrams and links to photos.

2.17.2. Background

In an effort to improve capacity, some railways have introduced double-deck or even triple-deck trains. Triple-deck trains are usually restricted to car carrying freight trains but some double-deck trains have been built for both passenger and freight operations. In designing vehicles with more than one level, there are some restrictions which have to be taken into account. Of course, the first of these is the size. Will the vehicle fit inside the "loading gauge" or "kinematic envelope" of the lines over which it is to operate. The efforts to ensure the size requirements have led to some interesting designs.

There is also the question of weight. Railways are limited by the weight limits of the structures along the line. These are usually called "civil engineering limits" or some form of shortened version of this phrase. The limits imposed by the civil engineer are usually expressed in terms of "axle load" as tons. Many lines in Europe, for example, are limited to an axle load of 22.5 tonnes, whereas, in the UK, the upper limit is generally 25 tonnes. In the US, some heavy haul lines allow axle loads of up to 40 US tons or just over 35 UK tons.

2.17.3. The UK Experiment

Many of the routes in the extensive suburban network south of London had reached capacity by the end of the second world war in 1945 and ways were sought to improve them without expensive platform lengthening to allow longer trains. The answer was thought to be the double-deck train and an experimental 8-car electric multiple unit was introduced in November 1949. It was built according to the traditional Southern Railway pattern with "slam" doors provided for each seating bay on the lower level. The seat bays of the upper level were reached by a set of stairs at each lower bay. It was not possible for a level upper deck floor to be provided within the small British structure gauge. Loading of the train was slow and this was the main reason for it not being generally adopted. You can see photos of this train at the [Southern E-Group](#) web site.

2.17.4. Europe

Most routes in Europe have a larger structure gauge than is available in the UK and various railways have introduced double-deck rolling stock over the more densely used

lines. In France, there are a number of double-deck designs, the latest of which is shown in the diagram below.

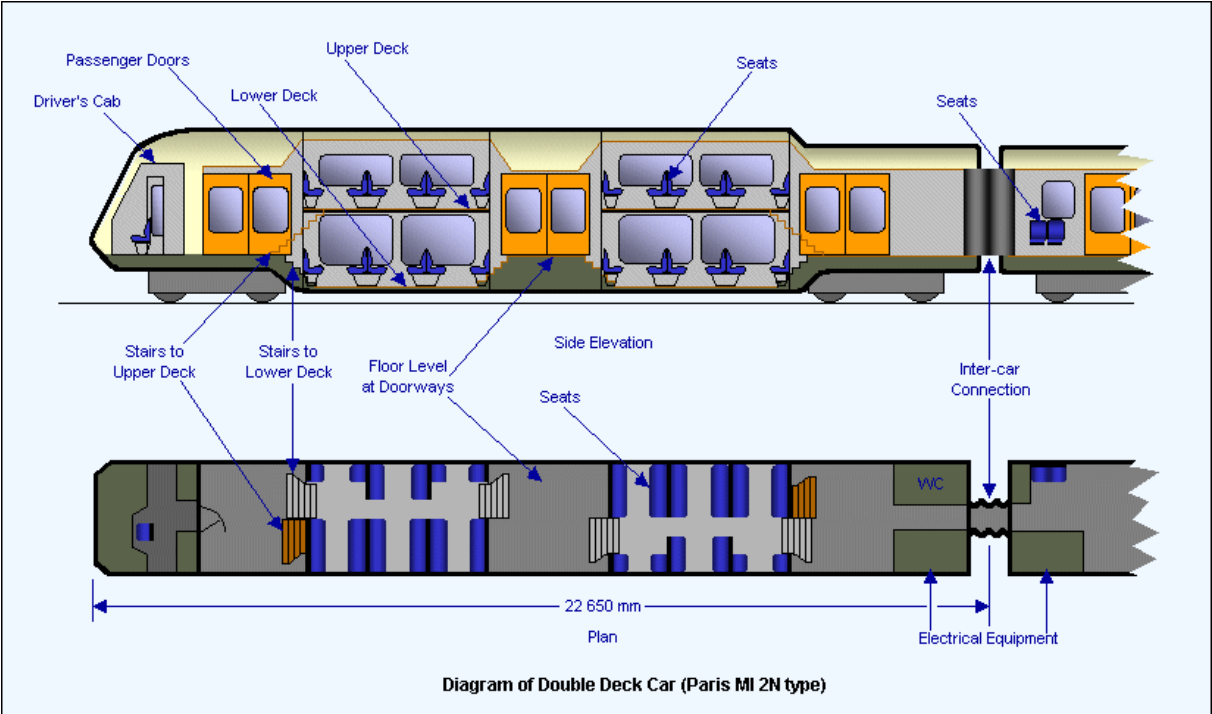

This example is typical of the designs used on suburban lines around Paris and other large cities in Europe. The passenger area is located between the bogies so that the lower deck floor can be sunk and thus give the height required for the upper deck. Entrance doors are provided over the bogies and in the centre of the car to allow rapid loading and unloading.

Although popular for suburban lines, the French have introduced a double-deck TGV (high speed train) design.

2.17.5. North America

The benefits of a large loading gauge have given North American railroads the scope to employ double deck coaches, or bi-level cars as they call them, on a much wider scale than in Europe. A popular design, first introduced in Toronto, Canada in 1977, is now in use on a number of suburban and interurban routes in the US and Canada. The car looks like this:

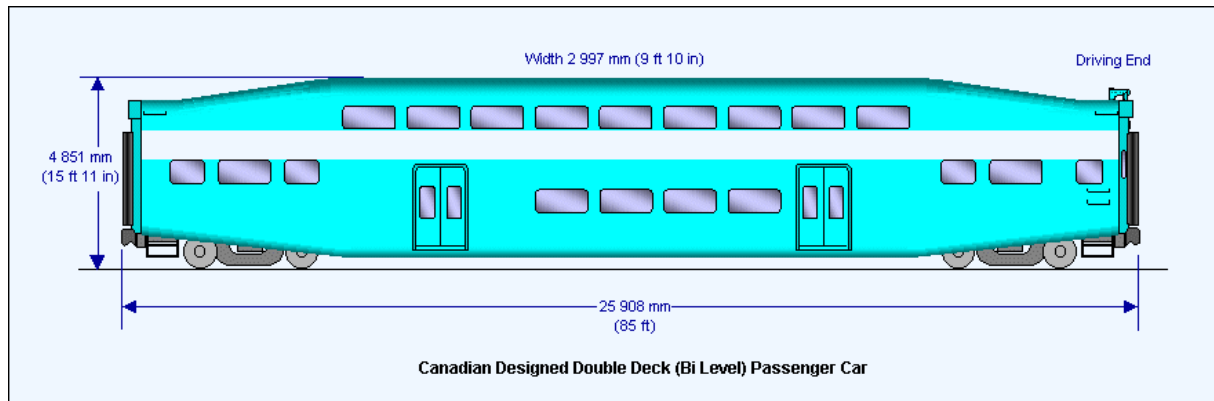

The design differs from the French model described above in that there are three seating levels. The lowest is between the two side entrance doorways, the intermediate level is over the trucks at each end of the car and the highest is directly above the lowest in the centre of the car. The highest level has the most seating space.

The cars are usually produced in two types, a driving trailer, called a "cab car" in the US, and a trailer car. They are normally used in push-pull formation with a locomotive at one end and the "cab car" at the other. The distinctive tapering shape of these cars makes them instantly recognisable. There are now over 500 of them in use in North America. Other designs are also used but these lack the tapered ends and some versions have only a single door in the centre of each side of the car. Many of these cars are designed as gallery cars, where the upper deck consists (as the name implies) of a gallery above the main (lower) deck. Some, such as Amtrak Superliners and Swiss intercity stock, have inter-vehicle connections at upper-deck level, effectively making that the main deck.

A word ought to be mentioned about Asia where the Japanese have a number of modern double-deck passenger train designs and in Hong Kong where a new double-deck train has been introduced between Kowloon and Guangzhou. Also, the extensive suburban network in Sydney, Australia is operated entirely by double-deck electric multiple units - all vehicles bought since 1964 have been double-deck.

2.17.6. Freight

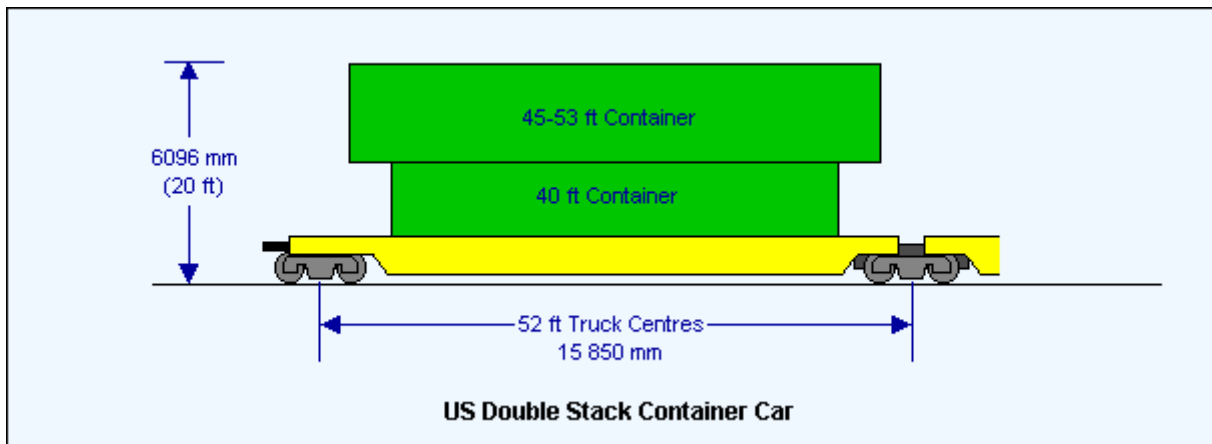

Freight railways have also developed multi-deck operations, most particularly in North America, where they are now common for container traffic. Purpose-built sets of container cars are now standard equipment on many lines and these can carry containers as shown in the diagram left.

The car itself is a well wagon which can carry two 20 ft containers or one 40 ft container at the lower level. A second container can be carried on top and may overlap the lower one due to its length, which can be up to 53 ft. Containers are secured to each other and on the wagon. Wagons can be individual bogie vehicles or articulated (as shown above) in 3-car or 5-car sets. The weight carried by the containers has to be limited to restrict the weight on the vehicle. After all, a 40 ft container packed with marble blocks will weigh a lot more than one carrying ladies underwear. The limit currently set is 125 tons (i.e. US short tons or 2,000 lbs.) for a 4-wheeled car, which is based on an axle load limit of 40 tons.

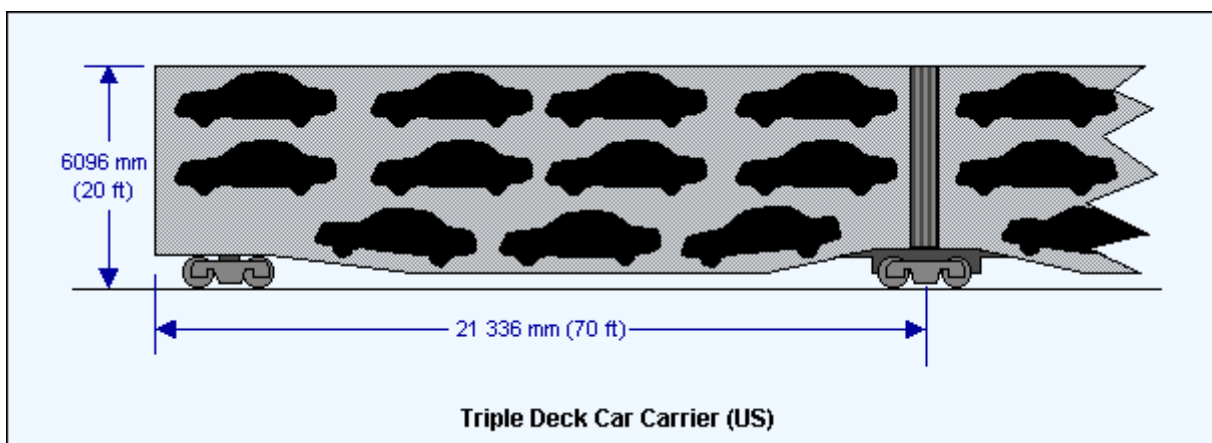

For new car shipping trains, the vehicle design has been developed to permit three levels of cars to be shipped inside an enclosed wagon as shown left.

The railroad cars are formed into articulated sets and are enclosed to prevent damage and pilfering. The articulated train sets are designed to allow a car to be driven across the coupling between one wagon and the next.

2.18. TRAIN MAINTENANCE

2.18.1. Introduction

An essential ingredient in the successful running of a railway is a well maintained system. Train maintenance is very important and this page outlines the methods and systems used in modern train maintenance.

2.18.2. Background

Railways are made up of complex mechanical and electrical systems and there are hundreds of thousands of moving parts. If a railway service is to be reliable, the equipment must be kept in good working order and regular maintenance is the essential ingredient to achieve this. A railway will not survive for long as a viable operation if it is allowed to deteriorate because of lack of maintenance. Although maintenance is expensive, it will become more expensive to replace the failing equipment early in its life because maintenance has been neglected.

Rolling stock is the most maintenance intensive part of the railway system and is the most vulnerable if maintenance is neglected. A stalled train will block a railway immediately and will reduce a timetable on an intensively used system to an unmanageable shambles for the remainder of the day. Reliability is the key to successful railway operation and maintenance should be the number one priority to ensure reliability is on-going.

2.18.3. Maintenance Facilities

Trains require special facilities for storage and maintenance. The basic design of these facilities has changed little in the last 100 or more years and, in many cases, the original sites and buildings are still in daily use. Sometimes, these old layouts have made adapting to modern maintenance systems very difficult.

The layout of a maintenance facility or depot will consist of a storage yard, a car cleaning area, an inspection and light maintenance shed, a heavy maintenance shop and, possibly, a separate locomotive shop or at least an area for locomotives if EMUs are the main service providers. A typical facility with space for EMUs, works trains and locomotives might look like this:

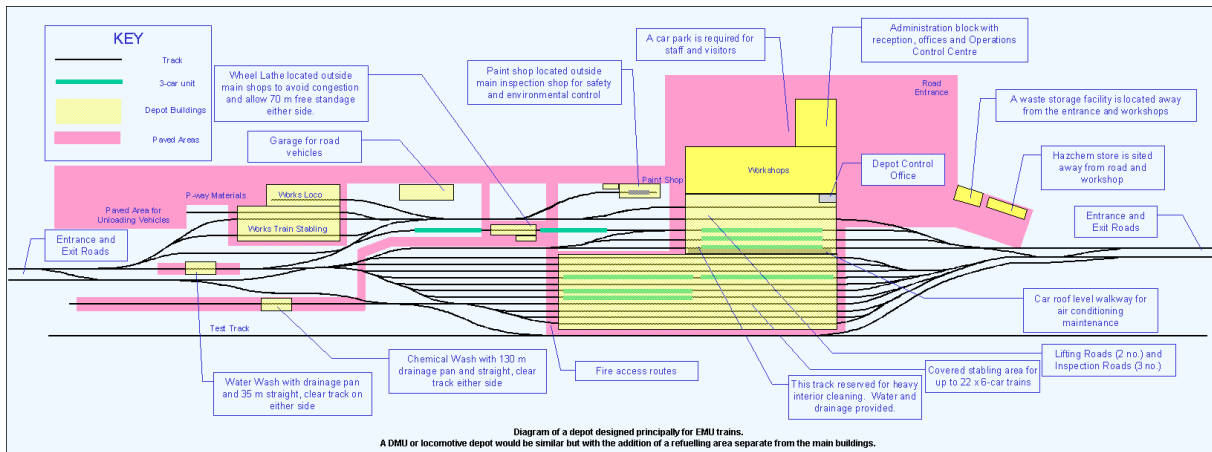

This diagram offers a layout for a depot (not based on anywhere in particular) but using best practice and with EMU operation in mind. Doubtless people will have other ideas for improvements so any constructive contributions will be welcomed. The operation of the facilities is described below.

2.18.4. Access

An essential feature of any depot is good access, both road and rail. Good rail access means that trains can get in and out of the depot without delaying trains on the main line and without upsetting operations within the depot. It is no good if a train coming in has to stop at the depot entrance while the driver gets instructions from the shunter or depot control office and the rear of the train is still standing on the main line. This can remove two or three paths from a timetable. Usually a long access track into (and out of) a depot is required, if space is available. If the railway is equipped with ATP (Automatic Train Protection), the changeover between ATP and manual operation will probably have to take place on this track. This must be carefully incorporated into the depot track design.

Road access is equally important. Large items of equipment may be needed to be delivered to the depot (transformers, pre-assembled traction units) and space to allow heavy trucks to get into the depot and turn, unload and exit must be provided. In some cases, it is necessary to provide car delivery access by road. Hard standing areas and unloading facilities like cranes or gantries must be considered when designing such a depot. The hard standing needs to be located over or near a suitable track so that cars being delivered can be craned off the road vehicle and mounted onto their bogies, which have been delivered in advance and are already on the track. The craneage can be hired in if the permanent installation of such equipment is not considered justifiable.

2.18.5. Cleaning and Stabling

Trains are stabled in depots or sidings when not in use and they need to be cleaned and serviced. Cleaning means a regular exterior water wash and interior sweeping and

dusting or vacuuming. At longer intervals, seating upholstery and carpets must be shampooed. Exterior washing is usually means a drive through washing machine which will wash the sides and, perhaps, the roof. Suitable facilities must be provided in the stabling areas where trains are stored. Water, power and toilet cleaning systems need to be provided in such areas, adjacent to each train to be serviced. Access to trains must be designed so that cleaning staff can reach them safely whilst carrying their equipment. This usually means floor height walkways alongside trains, or at least up to the first car of a set if through inter-car connections are available.

The layout of a stabling area is important. Ideally, each road should have an exit route at each end, so that, if one end gets blocked for any reason, trains can still get out the other end. There is no reason why two trains should not be stabled on each road if the length is right, again provided an exit is available at each end so that, if one train fails and is not sent out on time, the other is not blocked in. Of course, site availability is always an issue and compromises are inevitable. It may even be necessary to stable two trains on a single ended track. Even this is viable if management of the fleet is flexible and allows trains due for entry into service to be swapped at short notice. This is one of the essential skills of a good depot supervisor.

Train stabling areas are traditionally outdoors largely because of the expense of constructing large sheds. However, covering the stabling areas with some sort of weather proof structure is always preferable. It protects the trains and the staff working on or around them and reduces contamination by pollutants, frost, snow and wind damage. A covered area will also provide some benefit in hot conditions and could help to reduce the air conditioning costs.

2.18.6. Toilets

Modern trains which have toilets need to have them serviced regularly. Although not shown in the above layout, a toilet discharge facility is required in any depot where trains have toilets. The discharge has to be done away from the main buildings and where there is road access for the removal of effluent if it cannot be disposed of down a sewer. Emptying of effluent tanks is normally followed by rinsing and then recharging of the system with flushing water containing formaldehyde to break up the waste matter.

2.18.7. Train Washing Machines

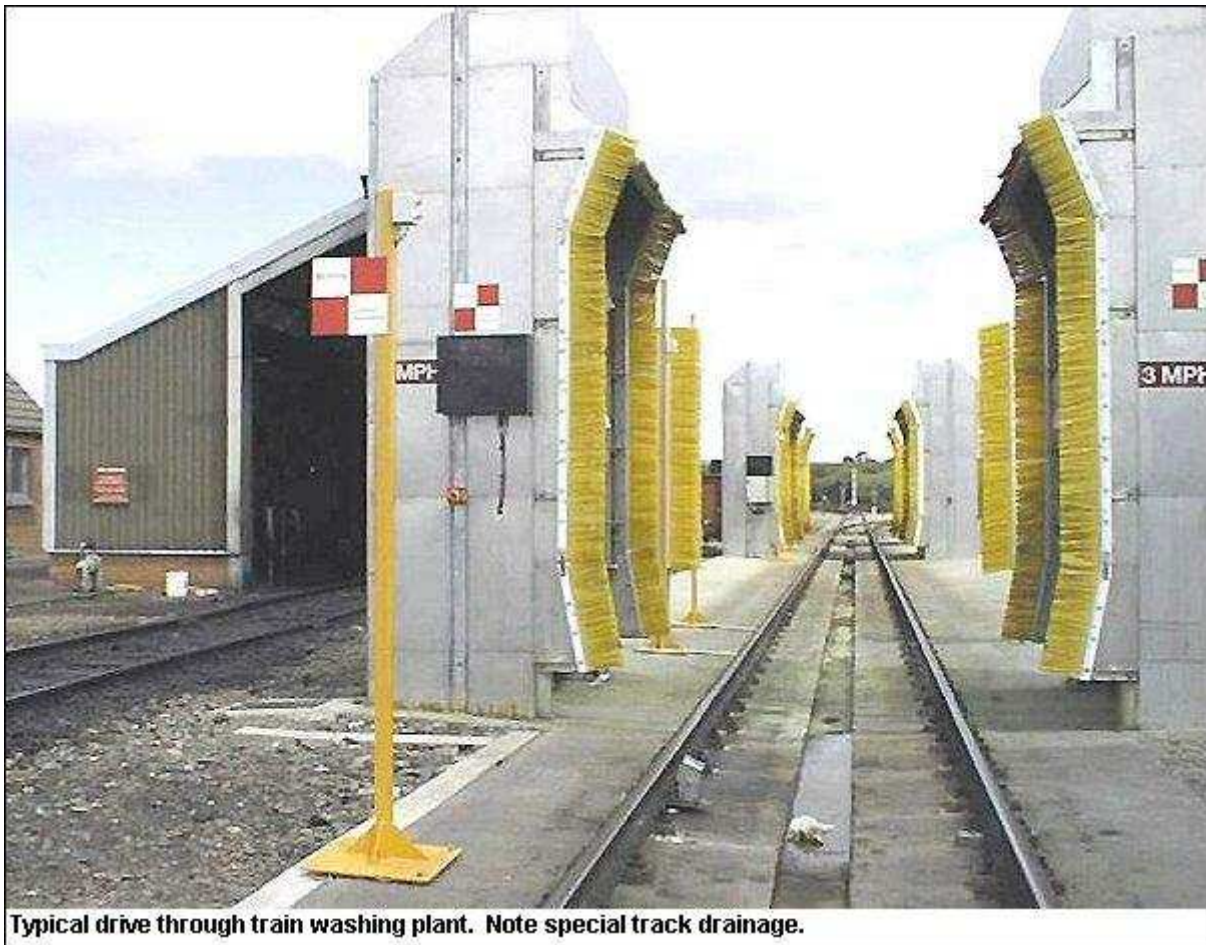

These (photo left) work on the same principle as a car wash, except that, usually, the train is driven through the wash and the washer itself stays in one place. Some designs of train washer work like a very long car wash, where the train stands still and the washer moves during the cleaning cycle but these are rare. Normally, water is used for a daily wash, while a chemical wash is used at less frequent intervals usually several weeks. Many daily washes have a detergent added to assist the process. In referring to a daily wash, this might extend to three days between washes, depending on local practice and degree of pollution and dirt collection.

Washing machines require that the track on either side is straight for at least one car's length. This is to ensure that the car goes into the wash straight. There will also be a need for proper drainage facilities, complete with waste water management and, for the chemical wash, waste retrieval using a clarifier or separator. It is usual to use recirculating systems nowadays, reusing the water from the final rinse at least, if not the 'ready mixed' water.

Washing machines may need a roof under certain conditions and they must be protected from adverse weather, particularly cold. Freezing temperatures will play havoc with the

pipes of a poorly protected machine. Most operators do not wash under freezing weather conditions, so as to avoid ice forming around the doors and other moving parts. Ice will quickly prevent train doors from operating and will render a train useless as a result.

Chemical washes are used for heavy cleaning and the chemicals used will often require the train to stand for some time while the chemical reacts with the dirt on the car body. The standage must be protected against drips and the waste collected. In places where there is space, it is advisable to do the chemical wash where it is protected from the weather. Some form of special ventilation is likely to be required. In some facilities, the chemical and water washes are contained in the same washing machine.

2.18.8. Wheel Lathe

Most modern depots are equipped with a wheel profiling facility known as a wheel lathe. These are normally designed so that the wheels can be reprofiled while still on the train. Removing the wheels requires the train to be lifted and this is an expensive business and very time-consuming. To avoid this, the underfloor wheel lathe or "ground" wheel lathe was developed like the one shown in the photo left.

Wheels can be removed from a train by a "wheel drop", where the wheelset is lowered underneath the train into a basement below the depot floor. Sometimes, whole toolrooms are provided in such areas but the ground conditions sometimes make such places difficult to keep dry and difficult to conform with modern evacuation requirements.

Modern wheel lathes can also reprofile a wheelset which has been removed from the train. Otherwise a separate wheel turning facility has to be provided in the workshop. Cutting has been the most common method of reprofiling but, recently milling machines, have been making a comeback as they can offer a longer tool life and better tolerance control on diameters.



An underfloor wheel lathe for multiple unit rolling stock built into the floor of a depot. The train is pulled or pushed slowly onto the machine so that it can be stopped and positioned exactly as required. The rails under the wheels are removed and the wheels connected to a drive system. The profile of the wheel is set by the machine operator and the wheels are driven round by the machine while the new profile is cut by the fixed tool. Some machines use a milling process instead of cutting.

Train wheels wear just as car tyres do and they need to be checked regularly. When the wear reaches certain limits, the treads either have to be reprofiled to the correct shape or the wheels replaced. Reprofiling wheels is a slow and expensive process but train and wheel design and maintenance has improved considerably over recent years, reducing the periods between visits for reprofiling. Even so, there are still persistent cases of railways running into unforeseen or unusual wheel wear problems and the wheel/rail interface still needs a lot more research before it is fully understood.

Wheels on a bogie or wheels on a single vehicle must be reprofiled within limits compared with each other. For example, a standard set for one type of passenger coach says that wheels in the same bogie must not vary in diameter by more than 5 mm. Wheels under the same coach must not vary more than 10 mm on different bogies. The most modern vehicles might require a tolerance as low as 3 mm. When wheels which drive a speedometer are reprofiled, the speedometer will have to be adjusted to compensate for the difference in wheel diameter caused by the reprofiling.

Some modern wheels lathes are designed to turn both wheelsets on a bogie at the same time. These "double-headed" lathes have developed as a result of electronically controlled AC motors, which require that the motors in the same circuit turn at the same

speed so as to match the inverter frequency. This makes it essential that wheel diameters with motors within a traction power circuit are equal.

Although it might seem obvious, the roundness of wheels is important, especially at very high speeds. An eccentric wheel can cause extreme loads on the wheel, axle, bearing and suspension, leading to failures. An "unround" (out of round) or eccentric wheel is alleged to have led to wheel tyre failure of a German ICE at Eschede in 1998, causing a high-speed crash with heavy loss of life. The wheel is alleged to have had an eccentricity (difference between major and minor axes of the ellipse) of 1.1mm, against a limit of 0.6mm. Wheels are often damaged by skidding during braking. Skidding (called sliding) causes a flat patch (called a "flat") to wear on the tyre and, when the wheel begins rolling again after a slide, the familiar "tap, tap, tap..." of the flat will be heard. Overheating during braking can also damage a wheel, as shown in the next photo:



Even if wheels, by some lucky combination of circumstances, do not wear significantly, reprofiling to remove work-hardened metal is likely to be needed at around 1 million km, otherwise Martensite fragments can drop out of the wheel tread, leading to the type of damage shown in the photo above. This damage can also be caused by local overheating during skidding and/or braking.

2.18.9. Leaves on the Line

One of the major sources of wheel damage in temperate climates with deciduous trees is fallen leaves.

Fallen leaves really can disrupt rail services – not just here in Britain, but all over Europe and North America. The scale of the leaf-fall problem and the cost of keeping services running smoothly is huge:

- a mature lineside tree has between 10,000 and 50,000 leaves thousands of tonnes of leaves fall onto railway lines each year
- there are 20,000 miles of track to keep clear in Britain
- the annual cost of repairing damage to trains and track from leaf fall is over £10 million
- lineside vegetation management costs over £5 million each year
- the cost of felling large trees is between £20,000 and £50,000 per mile.

It is impossible to predict exactly when the leaf fall season will start and how long it will last, but the weather can provide a guide to its likely onset and how serious it is likely to be for the railway. A severe leaf fall season often follows a wet summer. It starts with a hard frost, followed by a high wind and a period of dry weather, which causes large amounts of leaves to fall over a short period of time. But traditionally, autumn is the season of mists and mellow weather, which spreads leaf fall over a longer period and reduces the severity of the problem. How do leaves on the line affect trains? Think of leaves on rails as black ice on roads and you'll begin to understand the nature of the problem. We're not talking about piles of dead leaves, but a hard slippery layer that coats the rails and is very difficult to remove.

Briefly, this is what happens: leaves are swept onto the track by the slipstream of passing trains light rain falls train wheels crush the wet leaves at a pressure of over 30 tonnes per square inch this compacts and carbonizes the leaves, forming a hard, Teflon-like coating on the rails. As a result, trains have to operate at slower speeds to ensure safety and to reduce the potential for wheel slip and spin. This means that drivers have to brake earlier for stations and signals and move off again more slowly. Consequently, train services can be delayed. If a train can't move because its wheels can't grip the rails, often there is no alternative route, therefore following trains are delayed or have to be cancelled.

In addition to causing severe disruption to passengers, the damage inflicted on train wheels during sliding and spinning on rails is considerable and means some trains have to be taken out of service for expensive repair. The rails too can be damaged, costing

many thousands of pounds to repair each year. So what is the rail industry doing about it?

Network Rail, the UK body responsible for maintaining the rail network, is working to eliminate or minimise the problem of leaves on the line. They have a fleet of special 'sandite' trains, which spread a gritty paste on the rails to give trains improved adhesion. Known problem areas such as deep cuttings and steep inclines are targeted in order to minimise delays. There are also static machines to apply sandite at known trouble spots and mobile applicators, which can be used by track workers.

High pressure water jets are also used to remove crushed leaves before they form a hard coating. Leaf guards can be positioned around the track to stop the leaves being blown onto the rails and, in some cases, it is necessary to fell problem trees. However, to protect the environment, these are replaced with smaller leafed trees such as hazel, cherry and holly. Network Rail's tree surgeons take advice from conservation specialists to minimise the impact tree management can have on wildlife. For example, no work is planned during the main nesting season. Trains are also fitted with sophisticated sanding equipment to improve traction on slippery rails, the equivalent of ABS on a car. The driver can apply the sand when wheel spin occurs during acceleration, or it can be applied automatically (Source Network Rail).

2.18.10. Inspection Sheds

Special facilities are required to carry out rolling stock inspections. A properly constructed building, capable of accommodating a whole train, should be provided. Access to the underneath of the train is essential and this must be designed to allow reasonable working conditions and safety. There are various ways of doing this. The most common used to be a pit provided between the rails of the maintenance tracks and, sometimes, pits on either side of the track as well, to allow access to the sides of the underframe equipment. A more common approach today is the "swimming pool" design, where the floor of the shed is sunk and the tracks are mounted on posts. This gives better access and improves the light levels under the cars.



Interior of inspection shed at London Underground's Ruislip Depot showing the centre and side pits provided to allow access under the train. This arrangement would not normally be designed today because of the difficult access and poor natural light..

Inspection shed with pits



Interior of inspection shed at Ho Tung Lau, KCRC Hong Kong, showing "swimming pool" layout of floor with trains standing on rails mounted on concrete posts to give underfloor access. Note also the roof level walkways on the outside of the trains to give access to pantographs and air conditioning units.

Inspection shed with "swimming pool"

2.18.11. Shore Supplies

Inside train sheds and shops, it is necessary to provide shore supplies for trains and power for tools and maintenance equipment. Where overhead electric traction is used,

the overhead wires are usually installed inside inspection sheds but not in shops where vehicles are lifted. If it is necessary to get access to the roofs of trains, the overhead current must be switched off and the switch secured by a lock. Any person working on the roof will have a personal access key for the lock to ensure the current remains off until the work is complete and it is safe for it to be restored. The access stairs to the roof level walkway will also have a locked gate which can only be unlocked if current is off. A system like this is shown in the first photo below.



Interior of maintenance depot of the Sheffield (UK) Supertram. Note that overhead walkways are provided to give access to the electrical equipment mounted on the roof. Pits are also provided for under car access.

Interior of inspection shed showing overhead walkway with access gate.

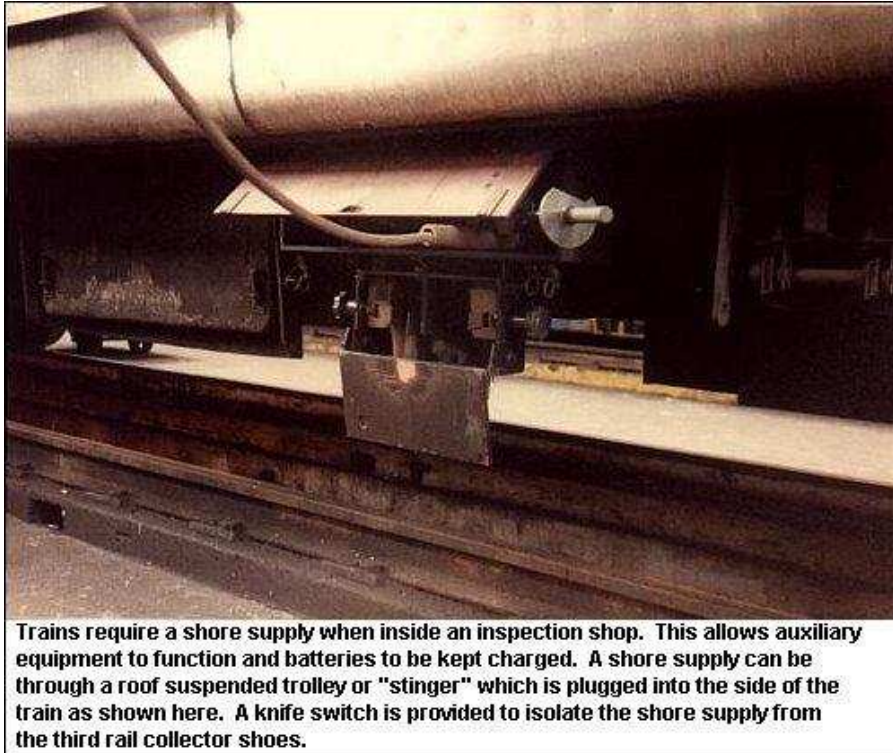

Knife switch and shore supply lead on a subway car.

In the modern depots built for the Eurostar Channel Tunnel trains in London and Paris, the overhead catenary in the workshops is designed to swing away from the roof when required to allow access to the roof mounted equipment.

The second photo above shows a shore supply attached to a New York City subway car, which has a third rail traction system. For safety reasons, the sheds are not equipped with the third rail, so a supply through a long lead is provided. The lead is plugged into a socket on the side of the train. Various systems are used around the world. In the case shown above, the shore supply socket on the car has a knife switch to isolate the current collector shoes from the supply. This is to avoid electric shock risks to persons working on or near the shoes. In older installations, this facility is not provided and a shore supply will energise all electrical equipment on the train, including the shoes. In these situations, special precautions have to be taken to ensure no "overhead leads" or "stingers" are inserted on a train being worked on.



For third rail systems, the shore supply cables are usually fed from electrified rails suspended from the shed roof. The cables are hung from trolleys running along the rails so that the supply is available along the whole track.

It is common to use the overhead leads to power the train out of the shed until the leading collector shoes are in contact with the current rails outside the shed. This is sometimes called "railing". The train is then stopped and the overhead leads removed. The leading car is then used to drag the rest of the train out of the shed. Care has to be taken to ensure all leads are removed before allowing a train to leave the shed and enter service.

In the US, the "railing" procedure is often performed "on the fly" (with the train moving), since the shore supply is connected directly to the collector shoes, which are large paddles. The live end of the "stinger" rests in a hole on the shoe or is clipped to the shoe by a large spring clip.

2.18.12. Lifting

The traditional method for accessing bogies was to lift the car body off the bogies by use of an overhead crane or cranes as shown in the left hand photo below. Each vehicle to be lifted has to be separated from its fellows in the train and dealt with separately. If one car in a set is defective, it has to be uncoupled and pushed into the shop for lifting. To access the bogies, the overhead crane is used to lift one end while the bogie is rolled clear and then the body is lower onto stands. Then the other end is lifted, the bogie rolled clear and the body lowered onto two more stands. Motors, wheels and other items can then be worked on or removed from the bogie as necessary. Naturally, this takes up a lot of track space in the shop and requires time spent on separating the vehicle from the train and then from its bogies. For overhauls, the bogie may be removed to a special area where it is placed on stands for stripping and refitting work.

A quicker lifting method is to use two cranes which lift both ends of the car body together and free both bogies at the same time. The body can then be removed to another part of the workshop for maintenance.



A traditional lifting method where the car body is raised by a pair of overhead cranes and then lowered onto stands. The body can be removed to other places in the workshop or stands provided where it is lifted.



Car being lifted in a workshop by a pair of overhead cranes

Jacks are the usual method of lifting nowadays. Vehicles can be lifted individually or, if a fixed formation is used for normal service, more recent practice has been to lift the whole train set. This is done by synchronised jacks. The jacks are linked by control cables and controlled by one person from a control desk. The big advantage of this system is that you don't have to break up the train into individual cars to do the work on one vehicle. The time saved reduces the period the train is out of service.

Underfloor jacks are also becoming more popular as shown below.

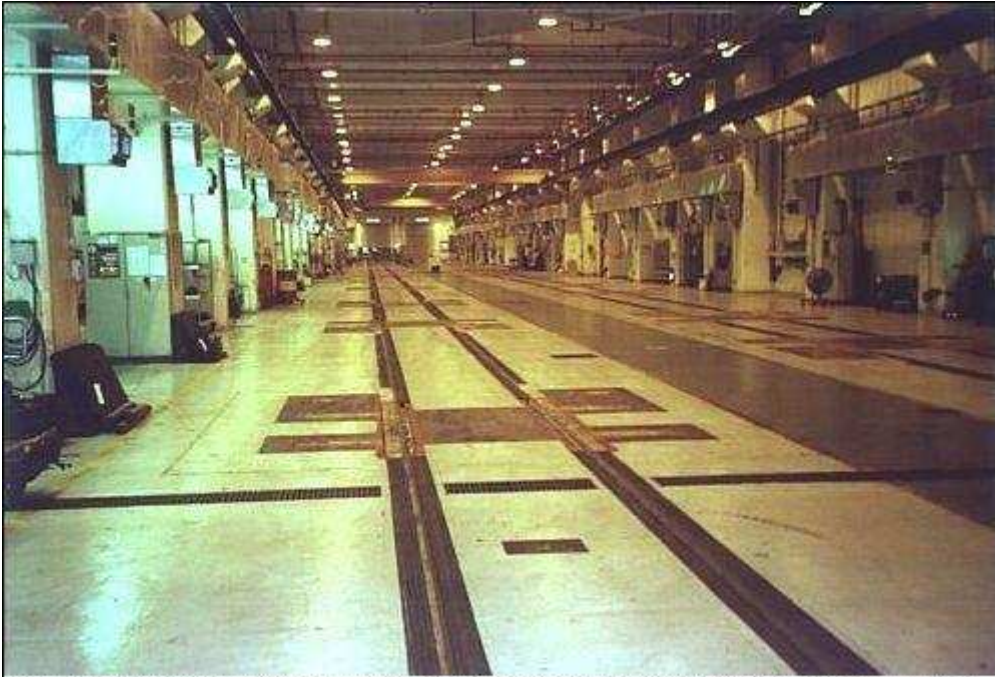

Workshop lifting area (KCR Hong Kong) using underfloor lifting stands. There are few obstructions in this layout although the workshop is quite small. Overhead cranes are provided for lifting items of train equipment like air conditioners.

Workshop with underfloor jacks

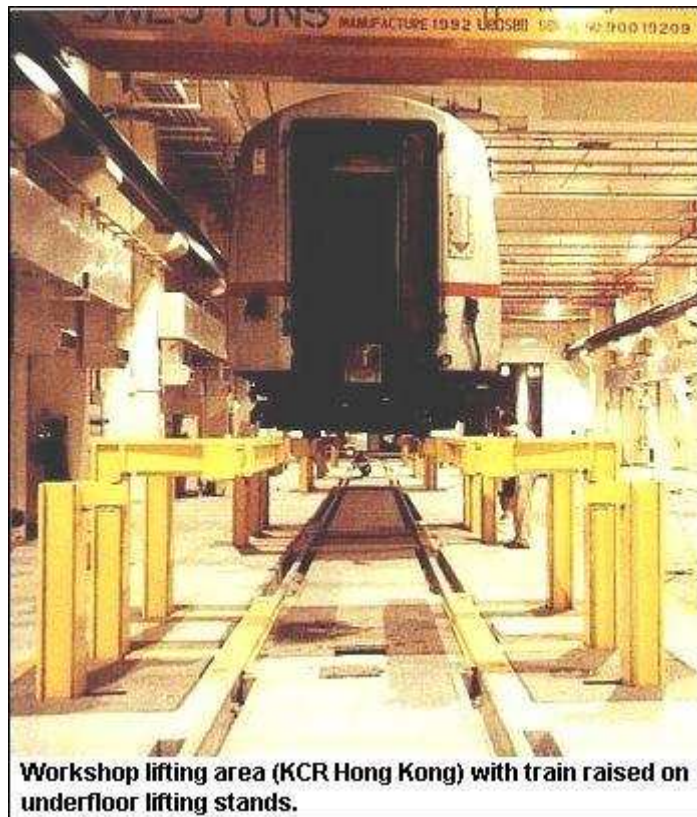

Workshop lifting area (KCR Hong Kong) with train raised on underfloor lifting stands.

Car lifted with underfloor jacks

Again, the lifting system is synchronised to allow several cars to be lifted at the same time if necessary. This is quicker than uncoupling each vehicle, especially if there is only one requiring attention.

Rolling stock can be lifted on a track where there is no pit, especially if there is a need to exchange a piece of underfloor equipment. A fork lift truck can be used to do this if there is enough room at the sides of the trains for it to manoeuvre. Otherwise a small scissors lift table can be used. In all cases, it is essential to ensure that the floor will take the weight of the train raised on jacks. Most modern rolling stock is designed to be lifted with its bogies still attached so that exchange of one piece of underfloor equipment can be carried out on a lifted train without disturbing any other cars. Bogie Drops

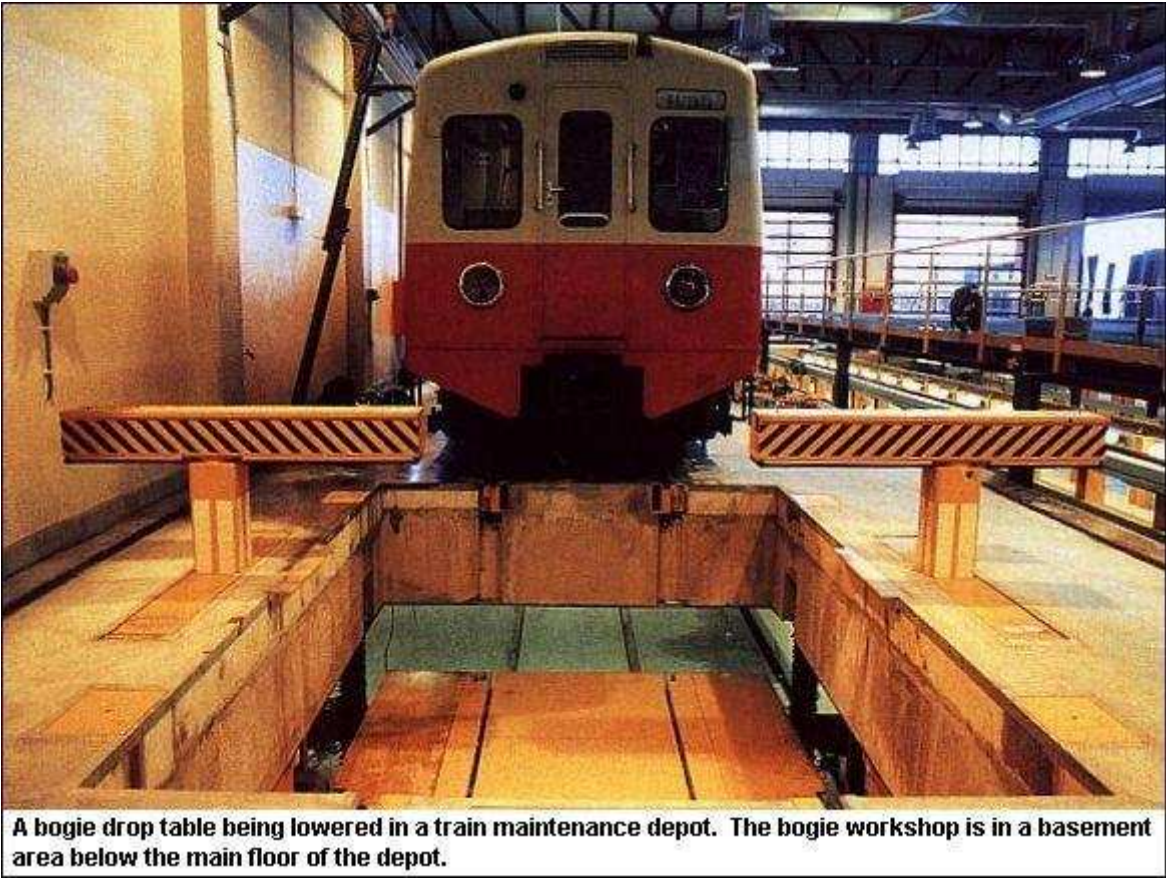

A bogie drop table being lowered in a train maintenance depot. The bogie workshop is in a basement area below the main floor of the depot.

Bogie drop table



Bogie being lowered

heightAnother system used in some shops is the bogie drop. The train is run over the lifting road, which has a pit and is positioned so that the bogie to be removed is located over a special section of track. The bogie requiring removal is disconnected from the train, using the pit for access. The car bodies are then lifted, leaving the disconnected bogie on the track. The section of track where the bogie is located can now be lowered into a basement area and the bogie removed and replaced by a fresh one.

heightA variation of this system has the train lifted by raising the sections of track under the bogies. The car bodies are then supported by stands placed under them and the bogies to be changed are disconnected. Once free, they are lowered to floor level and serviced or exchanged for new bogies. Turntables can be installed to assist in the removal of the bogies to other maintenance areas.

2.18.13. Maintenance Workshops

It is still common to see workshops for railways provided with tooling and equipment to allow a full range of engineering tasks to be undertaken. This will include milling, boring, grinding, planing and cutting machines as well as part cleaning facilities (including bogie washing and car underframe cleaning or "blow-out" as it is sometimes called), plus electronic and pneumatic testing shops. Good storage and materials management facilities are also needed. Computerised systems are now widely available.

Not only does the rolling stock require maintenance but also trackwork, traction power equipment, signalling, communications equipment, fare collection systems, electronics of

all types and buildings maintenance. The main depot of a railway has to be equipped to handle all these. Works trains will be needed to ferry equipment and staff to work sites along the line and these will be serviced at the depot. Refuelling facilities will be needed for diesel locomotives and DMUs. Storage for hazardous materials and fuel must be in a secure place with proper fire protection facilities. Waste disposal must also be properly managed and waste recovered if possible.

2.18.14. Maintenance Programmes

Rolling stock maintenance can be programmed in one of three ways; by mileage, by time or by conditioning monitoring. Of these three methods, condition monitoring is the most recent. Traditionally, maintenance was carried out on a time basis, usually related to safety items like braking and wheel condition. Many administrations later adopted a mileage based maintenance system, although this is more difficult to operate as you have to keep records of all vehicle mileages and this is time consuming unless you have a modern train control and data gathering system. There is also the fact that a train will deteriorate just as quickly if it is stored unused somewhere as it would if it was being run in service every day. Only the items which deteriorate will vary.

Modern trains should be able to run for some weeks without a maintenance inspection. One train operating company in the UK wants to get inspection intervals out to 90 days on its new EMUs. Comparing this with the 3 days between inspections which electric trains got at the beginning of the 20th century and the 7-daily inspections still being carried out in the 1980s on some similar fleets, shows the rapid progress of the last few years. It is impossible to give fixed time or mileage periods here for maintenance as each type of train varies. There are often special rules for high speed trains and for heavy freight. Individual railways have adapted their maintenance to the local conditions and, in many places, certain types of safety inspections are required by law. As an example, the Channel Tunnel Shuttle trains cover about 5,000 kms a week and get an initial inspection every seven days. However, the French high speed trains (TGV) are given a daily visual inspection of the underneath and the pantographs. The toilet system is emptied every three days and the trains return to their base depot every 5-6 days for their 4,500 kms inspection. Examination of equipment such as traction motors and bogies takes place every 18 days.

Condition monitoring is achieved by checking the operation of the equipment and only changing something if it shows signs of wear beyond preset limits. The checking is often done using on-board monitoring and storing the data gathered in a computer for downloading at the maintenance facility. Of course, it is a recent development made available by the introduction of information technology on trains. Such systems are now becoming so sophisticated that it is possible to have failure predictions of some items of

equipment. A combination of on-board data gathering and depot maintenance systems have been developed into complete maintenance management systems on lines where modern rolling stock has been introduced.

2.18.15. Failures

As already mentioned, reliability is the key to running a successful railway. If the equipment, especially the rolling stock, is not reliable, the railway is not workable. A good railway management will keep track of its performance and its failures and, by this means, ensure that problems are eliminated before they become endemic.

A number of methods can be used to monitor performance. The traditional way was to measure on-time performance. The number of minutes late of each delayed train was recorded and collated into daily, weekly, monthly and annual statistics. Usually, the time of arrival at the destination station was the basis but an intermediate delay is often also used to quantify a delay to a service. The cause of each delay is decided yes, it does require a decision, as we will see later and the cause investigated. In the case of rolling stock, there is probably a technical reason for the delay and there is usually a check to see if other, similar incidents have taken place. If so, there may be a design fault which needs a modification to the fleet to rectify. Checks are also done on maintenance procedures to ensure that the process is being carried out properly and, if so, whether the system needs to be modified.

Causes of delays are investigated to find out what happened. Imagine the case of a train which comes to a halt in the middle of nowhere. The driver notices that he has lost all the brake pipe air so the emergency brake applied. After finding that the conductor has not stopped the train and no passenger alarm valves have been operated, he starts trying to find out the cause. After a while he find the cause a burst hose between coaches. Back to get a spare hose. Oh dear, he hasn't got a spare hose. He has to isolate the defective portion of the train and limp on to the next station where he can get a hose and repair the train. Delay to his train? 25 minutes actual delay at site plus 17 minutes lost going to next station plus 35 minutes replacing the hose. Total delay 77 minutes. But what was the cause?

Initial observation of this incident would suggest a defective hose. The delay would be allocated to rolling stock and the engineering department would have a few words with the supplier to tell him what happened and discuss possible causes and remedies. However, in our case, an enquiry is held because the conductor on the train says he heard a loud bang under the train just before the emergency stop. The enquiry finds that, upon investigation, a shovel was found by the track in a bent and battered condition. The underneath of the train shows signs that it was hit by something. The

damaged hose shows cut marks near the burst. It is concluded that the permanent way workers in the area had left a shovel on the track, it struck the train and damaged the hose. Allocation of delay: "Permanent Way" department. It wasn't a rolling stock failure at all, although it was aggravated by the lack of a spare hose, which is a rolling stock error. Eventually, as a result of some bargaining, the delay is split between the two departments, both of whose performance is measured on train service reliability.

Such investigations and the subsequent bargaining were traditionally part of the railway culture and have recently become more important since the commercialisation of the business. No one wants to be blamed for delays, since service performance is part of their contract and part of their payment structure.

2.18.16. Performance Measures

Rolling stock performance in respect of failures can be measured by MTBF (Mean Time Between Failures) or MDBF (Mean Distance Between Failures). It is sometimes measured by numbers of failures per year, month or week but this may not represent an accurate rate consistent with mileage. On the other hand, rolling stock does deteriorate rapidly in storage and this, in itself, produces failures, although these may not be the same failures seen under normal service conditions. Failure rates are sometimes quantified in service performance by availability. The performance is expressed as, for example, 95% availability. In other cases it is quantified as, say, 92% on-time. This is more unreliable as a statistic if the on-time regime is cushioned by huge amounts of "recovery time", as is often the case today.

Performance monitoring also depends on the real definition of a delay. At one time, the Inter City services in the UK were using 10 minutes as the definition of a delay. This was much derided in Europe, where on-time performance meant just that. If you were not on time, you were late. Perhaps a more equitable way to define a delay is by the loss of a train path. Most main lines will give a three minute headway or 20 trains per hour, assuming equal speeds and performance. A three minute delay will therefore lose a path and, in the commercial structure of a modern railway, deprive the track owner of the sale of a path to another train operating company. In a metro or suburban operation, the path will be two minutes or slightly less, so a two minute delay would be an appropriate measure of performance.

One other point about performance is that time out of service is as important as the frequency or duration of failures. Another measure applied to equipment is the MTTR (Mean Time To Repair). A short delay which requires a train to be taken out of service for repair become more critical is the train takes a week to get back into service. It's not

good design if the train owner has to lift the car off its bogies in order to replace a fuse. Short MTTR is another important part of good rolling stock performance.

2.18.17. The Development of Train Maintenance

Leaving aside the question of steam locomotive maintenance, which is another subject entirely, the regular inspection of motive power, coaches and wagons has long been a part of the railway culture. The need for inspections was based on the need to ensure the good condition of the structure of the largely wooden bodies of the coaches and wagons and the integrity of the wheels, axles and braking systems.

Example Wheel Inspection

As an example of how train maintenance has developed, we can look at wheels and axles. Wheels and axles were vulnerable to fracture, particularly in the early development of railways when manufacturing techniques were not as sophisticated as today, and they were checked daily for visual signs of damage. Many railways painted a white mark over the wheel tyre and hub so that any movement of the tyre on the hub was immediately noticeable. Wheels were also "tapped" struck with a hammer to ensure a "ring" was heard so as to confirm there were no cracks. In spite of these checks, there were occasional and sometimes spectacular accidents due to wheel or axle fractures on trains in service.

As early as the 1930s, techniques were developed to test axle integrity by electrical means. Magnetic particle testing was one system used, where energised particles of steel were applied to axles to determine the location of cracks. In the 1950s, an early form of ultrasonic testing was used. Nowadays, such systems are standard. This type of development process has taken place for all rolling stock systems, including those on locomotives, coaches and wagons.

Example - Brake Maintenance

Train brakes were always inspected regularly. In the early 1900s, electric multiple units (EMUs) used in London (UK) were inspected every three days, most of the work concentrating on replacing brake shoes (often called brake "blocks" in the UK) and adjusting the complex rigging used to connect the single brake cylinder to the blocks on each of the wheels. Many designs used two blocks on each wheel, a design known as "clasp" brakes. Setting these up to get even braking on all wheels was a skilled job requiring at least two men under the vehicle. As the blocks were usually made of cast iron and weighing around 28 lbs. (12.7 kilos), they were awkward to access and fit. On cars with traction motors, it was more difficult due to the reduced clearances. Later designs reduced the rigging, so that each bogie had a cylinder or, on modern trains, each

wheel or even each block had its own brake cylinder. The skill requirements were reduced but the bogie became very crowded and block changing became a job for very slim athletes.

Modern trains usually have disc brakes and pads are used instead of blocks. These are easier to change, being smaller than blocks, but the modern bogie is still a very crowded place see [Bogie Parts](#). During inspections of brake parts, only a percentage of blocks or pads get changed and a lot of time can be wasted looking at them to see the state of wear. Recently, a system developed in the UK called Padview, has been introduced to some depots. Padview takes a video image of the brake pads of a train as it enters the depot and compares the image with a computer stored image of a pad. The comparison generates a "go-nogo" output to tell the supervisor if the pad needs changing. A similar system has also been developed for checking wheel wear.

Aside from the mechanical features of brakes under the cars, a test of the operation of the braking system has traditionally been mandatory on a daily basis. Not all railways insist that wheels are checked to see if the blocks are applied on each but this is normally done during "reblocking". However, a test to see that the brake pipe is continuous throughout the train is essential, especially after coupling or uncoupling and after maintenance work. This is normally done by charging the brake pipe fully from one end of the train and checking that it has charged at the other end. This is followed by a reduction in pressure from one end and a check that the pressure has fallen at the other end. On US freight railroads, the train will have a system which electronically checks the pressure at the remote end to eliminate the manual check. See [EOT Device](#) for more information.

Modern brake systems can incorporate pressure sensors which determine brake cylinder pressure or even brake pad pressure. The reading is sent to an on-board computer or data unit and alarms are provided in the driver's cab if a unit reveals an unsafe condition. In maintenance, this facility can be used to download data indicating wear, failures or likely failures. Such facilities are now part of modern train maintenance management.

2.19. WHEEL ARRANGEMENTS

2.19.1 Introduction

This page describes the various systems used from time to time to describe the way in which the wheels are distributed under a locomotive.

2.19.2. Modern Diesel and Electric Locomotives

Starting with modern equipment and the usual method of describing how the driving and non-driving (carrying or trailing) wheels are distributed under a locomotive, there are two simple basic rules. First, the wheels are not individually identified, only the axles and, second, trailing wheels are allocated numbers and driving wheels are allocated letters. The letter or number refers to the number of axles in a single frame, for example:

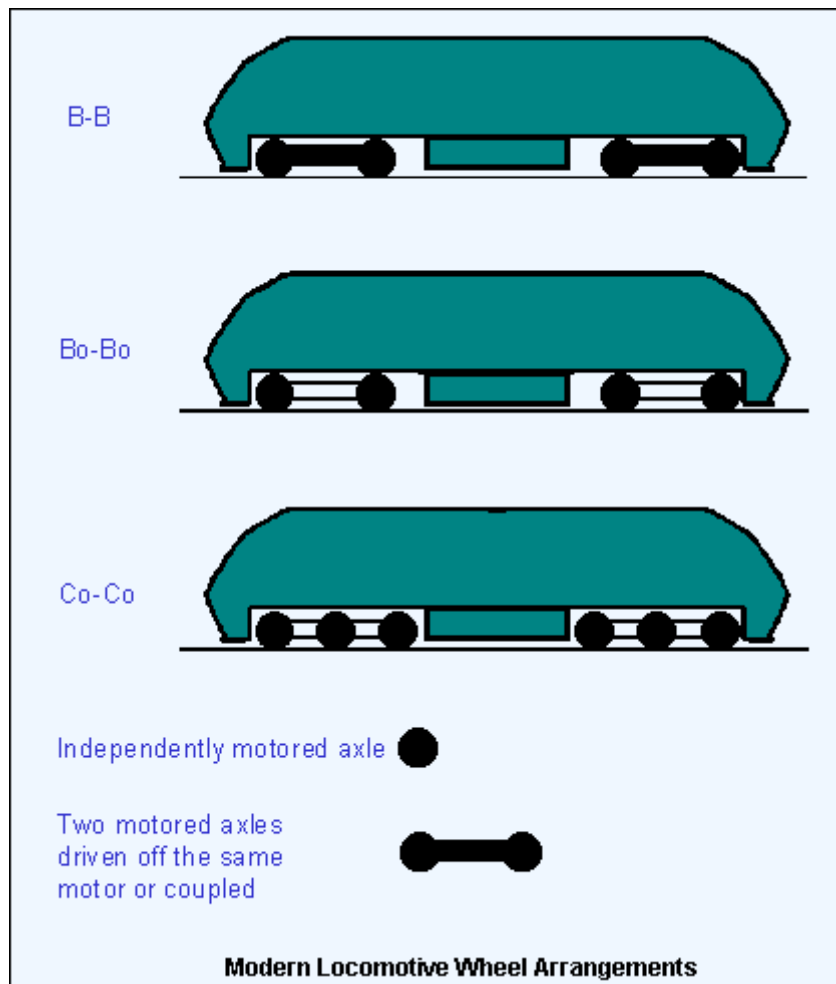

A locomotive with two bogies, each bogie having two axles is a Bo-Bo or a B-B. Both are shown in this diagram. The difference between a Bo-Bo and a B-B is that the two axles in a B bogie are coupled together, either by a coupling rod (once common but now obsolete) or because they are both driven by the same motor (example). Unfortunately,

over the years, some confusion has arisen because there have been a number of variations in the way these notations have been used.

On continental Europe, it is common to see a Bo-Bo described as a Bo' Bo'. The - (hyphen) which used to denote the separation between one bogie and the next under a locomotive has been replaced by a ' (apostrophe). The ' is used to denote a swiveling bogie, independent of the frame of the locomotive. This system is even used to describe the axles under a multiple unit train, for example:

2' 2' Bo' Bo' 2' 2'

which is a 3-car set with a leading trailer car, a centre motor car with all axles driven and a rear trailing car.

Further confusion has arisen because of the French habit of describing their locomotive classes with, for example, BB as a prefix to the locomotive number, regardless of whether the locomotive was a B' B' or a Bo' Bo'. They did the same with the CC notation. As the B' B' was very common in France it caused a lot of confusion unless you were an expert on their traction drive systems. The same problem has appeared in the US where the Bo-Bo or Co-Co arrangement is common but they are widely referred to as B-Bs or C-Cs.

One other feature is the use of a + instead of the between the bogie number or letter. This would indicate the bogies are coupled or articulated in some way.

2.19.3. Older Designs

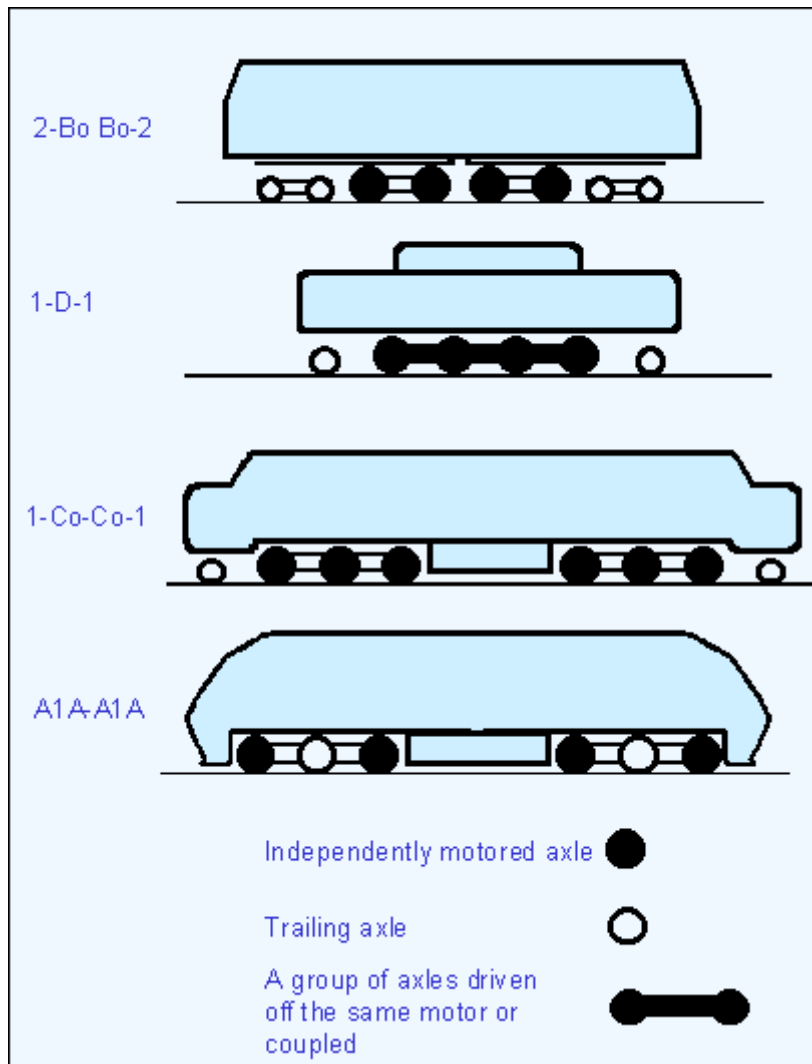

Diesel and electric locomotives designed during the first half of the twentieth century often absorbed some of the mechanical features of the steam locomotive. One such was the use of coupled driving wheels, often powered by one or two very large electric motors. They also included the use of trailing or carrying wheels. Some examples of these are shown below:

The 2-Bo Bo-2 is one which offers a strange arrangement. This is from an Italian design of 1935 where the 2-Bo was mounted under a "demi frame" attached to the locomotive at its rear end. Its Italian classification was written as (2' Bo) (Bo 2'). For those interested it was a class E 428 3,000 V DC electric locomotive.

The next example is a 1-D-1, the D referring to the four coupled driving axles in the centre of the locomotive. This was a 3-phase locomotive from 1922. I have not found a design of locomotive with greater than E (five) coupled axles under one frame.

The next two are more recent UK diesel locomotive designs, the 1-Co-Co-1 first seen in 1948 and later on the Class 40s and 45s circa 1960 and the A1A-A1A (Class 31) introduced in 1957. The latter design was adapted from a once popular design of the US.

One rare design seen in the UK was the Co-Bo, designed by Metropolitan Vickers. It was more an exercise in weight distribution than anything else. The non-standard design made it less attractive as a cost effective solution.

2.19.4. Steam Locomotives

Different systems for denoting steam loco wheel arrangements were developed in different countries. In the US and UK it was usual to refer to a steam locomotive type by its wheels rather than its axles. The wheel layout was described totally numerically by first the leading carrying wheels, then the coupled wheels (including the driving wheels) and finally the trailing carrying wheels, in that order, in a system invented by Frederic M Whyte in the US in 1900 e.g. 4-4-0 = ooOO, 4-6-2 = ooOOOo, 0-4-2 = OOo, 0-6-0 = OOO, 2-10-2 = oOOOOOo. A "T" at the end of a description e.g. 0-6-0T, indicated a tank engine, i.e. one not requiring a tender. A good list of steam locomotive wheel arrangements is available at the [Weville and Hypertext](#) R.R. site.

Some European railways used a modified form of the Whyte system where the number of axles was used instead of the number of wheels, 4-6-2 becoming 231. This was further developed by the French who used numbers for non-driven axles and letters for driven axles thus; 2C1. This was rearranged by British locomotive designer Bullied who placed the non-driven axles first in the order, then the driven axles, thus 21C. From the French system it can be seen how the non-steam locomotive axles notation system was developed. For a full list of the French and German systems of wheel notation compared with the US/UK version, see our [Steam Locomotive Wheel Arrangements](#) page.

TRAIN OPERATIONS

3.1. INTRODUCTION

This page contains some articles about the planning, crewing, movement and control of trains. It is not concerned with the type of trains except as how this might affect operation. It is based on modern practice around the world, showing some examples where suitable. It is not concerned with [signalling](#) except where it is used to control trains.

3.2. DEFINITIONS

First, it is important to set out some definitions. A train is defined here as one or more railway vehicles capable of being moved. It may consist of a locomotive (sometimes more than one) to provide power with various unpowered vehicles attached to it. It may consist of a multiple unit, i.e. several vehicles formed into a fixed formation or set, which carry their own power and do not require a locomotive. A train may be only a locomotive running light (deadheading) to a point elsewhere on the railway. A train may be passenger carrying, freight or, rarely nowadays, mixed.

A train may be manually driven (by a driver, operator or engineer) and may have other crew members (assistant driver, fireman, conductor and catering staff) to assist the driver and/or the passengers.

3.3. THE OBJECTIVE

A train is an expensive piece of kit. A locomotive now costs about US\$ 5 million and a coach up to US\$ 1 million depending on the type. A multiple unit (i.e. a self-powered train without a locomotive) can cost an average of US\$ 1.5 million for each vehicle, depending on type and size of order. This is a lot of capital to invest and it is essential to make sure it earns its keep. Trains sitting in stations and sidings may look nice but they don't earn money.

Crews are also expensive. They too, must be used efficiently and safely, which means regulating their hours but they will be needed to match the times that they are required on the trains. Allocation of crews is a scientific skill just as important as train control. For more information see [Train Crews](#).

The infrastructure of a railway is its most expensive asset. A new railway can cost US\$ 25 million per kilometre and this price will double to US\$50 million for an elevated urban line. An underground metro or subway can cost up to US\$200 million a kilometre in a country where protection against typhoons and earthquakes is required. See [Railway](#)

[Finance](#) for more information on costs. Maximisation of the use of the line of route is essential and train operations management will play an important part.

The objective of good train operations management is to use the route, the rolling stock and crews in the most effective way. This is what this page attempts to explain.

3.4. LOCOMOTIVE HAULED TRAINS

The traditional train comprises a collection of coaches (or freight wagons) with suitable motive power attached in the form of a locomotive. The train is made up of sufficient vehicles to carry the traffic offering and provided with enough power for the job. For passenger operations, one locomotive is usually sufficient. In heavy freight operations, this number might go up to four locomotives on the front and at some other places along the train.

A good deal of flexibility is possible with locomotive haulage. As long as the train weight remains within the capacity of the locomotive(s), any number of vehicles can be attached, although limits will be imposed by platform or siding lengths. Locomotives themselves can also be flexible, many being designed to cover a range of duties.

The advantages for locomotive hauled trains mean they are the best option for many railway operators around the world, particularly freight but, where traffic is dense, i.e. where a large number of trains are required, a more rational approach is necessary, particularly at terminals. In addition, in very predictable operations like commuter services or metro lines, fixed formation trains will be the most efficient.

3.5. TERMINAL OPERATIONS

One disadvantage of traditional locomotive haulage shows up at the end of the line. When a train arrives at a dead end terminal, the locomotive is trapped between the train and the buffer stops. The only way to release the locomotive is to remove the train and for that, a second locomotive is required. This second loco is attached to the other end of the train and will be used to provide power for the return trip. When the train has been removed, the first locomotive is released, moved away from the platform to a "loco siding" near the terminus and stored until used for the return trip of another train. This problem can be solved, if space is available. The train stops a distance from the buffer stops and a crossover to a run-around track is provided. This is sometime referred to as a "locomotive escape" and is used as shown in the diagram below.

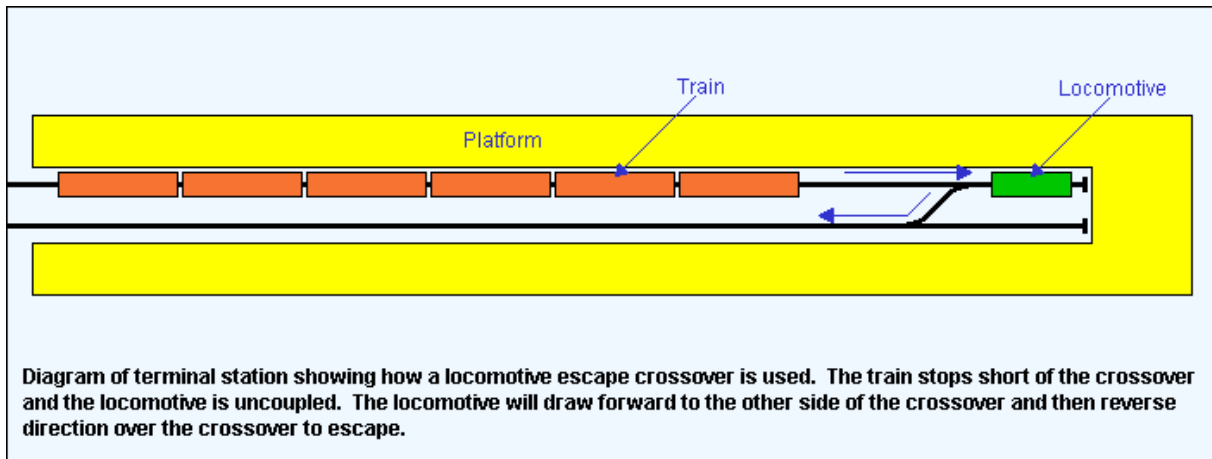

Often, the adjacent platform track is used but it must be kept free of other trains. Sometimes a scissors crossover is used. Of course, the arrangement would not nowadays be suitable for a major city terminus where space is at a premium and land is very expensive, so efforts are made to use tracks to the optimum. So, although locomotive changing operations at terminals were, and still are commonplace, where there is intense traffic, additional movements for loco changing can restrict the terminal capacity. Also additional locomotives are required to cover these terminal operations. To overcome all these limitations, the [Multiple Unit](#) was introduced.

3.6. MULTIPLE UNIT OPERATION

Locomotive operation of intensive services was rapidly phased out when electric traction, using "[multiple unit](#)" operation, was introduced late last century for US urban railway lines. Within ten years the idea had spread to Europe. The facility for the electric traction system to be spread out along the train, compared with cramming it all together into a bulky locomotive, allowed a number of small power units to be distributed underneath the floors of several vehicles in the train. They were all simultaneously controlled by the driver in the leading car through wires running the length of the train. Thus was born the electric multiple unit or EMU. In later years, DMUs (diesel multiple units) were developed using the same principles.

A modern passenger multiple unit train is now made up of a number of inter-dependent vehicles which cannot operate unless all the vehicles are of the right type and are coupled in the correct position in the train. Power and auxiliary equipment is usually distributed under more than one vehicle and is all controlled from the driving position. Vehicles in multiple units are usually referred to as "cars" and are known as "motor cars" if powered and "trailer cars" if not.

Multiple unit trains are formed into "units" or "sets" of two or more cars. They are often semi-permanently coupled together, only being uncoupled inside a workshop for heavy

maintenance. Units can operate singly providing driver's cabs are provided at both ends - or coupled to form longer trains. Some operations require two (or more) multiple units to be coupled together to provide sufficient capacity for a particular service. This also allows trains to be lengthened or shortened whilst in service by adding or cutting units.

Some multiple unit trains are designed so that a unit has a full driver's cab at one end only. At least two units, coupled back to back, are required to make up a train for service. In the US, a development of this type of formation, known as "married pairs", has been popular since the 1960s. Two cars, coupled together and electrically dependent on each other, form a unit and a number of these are coupled to form trains of four, six, eight etc. cars. Similar formations have since appeared elsewhere, e.g. London Underground's Central Line.

Multiple unit trains are mainly used for high density suburban operations where traffic levels are easily predicted and form constant patterns which allows fixed train formations. In recent years, long distance traffics have shown the same tendency and many railways are now adopting the multiple unit formation for these routes e.g. the French TGV, the UK HST, the Japanese Shinkansen.

Other advantages of the EMU are that it doesn't have to carry its own fuel, it takes it from overhead wires or an additional (third) rail and it is quick and simple to reverse at terminals. All you have to do was provide drivers controls at both ends of the train, connect them to the train wires and give the driver a key to switch in the controls at the end he wants to use. Locomotive changing is instantly eliminated, terminal space is released and trains can be turned round more quickly. All the driver has to do now is change ends.

Another form of multiple unit operation was adopted in the early 1960s when a new concept appeared called push-pull.

3.7. PUSH-PULL OPERATION

Push-pull operation was really only an adaption of the multiple unit principle but applied to a locomotive powered train. Assuming a regular level of traffic and an even interval service was required, trains could be formed with a locomotive at one end and a driving cab on the coach at the other end. If you could find a way of doing it cheaply by converting existing coaches, it could represent a big step forward. See [Development of Push Pull Operation in the UK](#) by Chris Grace.

The idea has now been adopted world-wide in two forms. One, as stated above, uses a locomotive at one end and a coach equipped with a driver's cab at the other end. The number of vehicles in between them may be varied seasonally if required but the

formation is not normally varied on a train by train basis. In the UK, the coach at the rear has become designated a Driving Van Trailer (DVT). It is used to carry luggage and passengers are not permitted to ride in it at speeds over 160 km/h.

The second push-pull form uses two locomotives, one at each end of the train. This was applied to the Channel Tunnel "Le Shuttle" trains and has also appeared elsewhere, notably in Taiwan. The two locomotives are necessary in these cases to provide sufficient power.

3.8. HIGH SPEED MULTIPLE UNITS

The modern two-locomotive concept for push-pull operation first appeared in 1959 with the UK's Blue Pullman series of trains. A diesel power car was provided at each end of a six- or eight-coach set. The concept was further developed in the 1970s with the UK High Speed Train (known as the HST) and in France with the TGV (Train à Grande Vitesse). The former is diesel powered, the latter electric but the concept is the same. Both these trains employ a power unit at each end with a set of passenger carrying coaches in-between. The Germans have joined the club with their ICE train. The only real difference between these trains and the original push-pull concept is that the newer trains were purpose built.

Not forgetting the Japanese high speed train concept; they were the first to introduce over 200 km/h running on a regular basis and have kept at the forefront of high speed train technology with their German and French counterparts. However, the Japanese HSTs have always been multiple units in the original sense, having many power cars distributed along the train.

The HST name was first used for diesel [multiple unit](#) passenger train developed in the UK for 125m/hr running. It is now generally accepted as the definition for any passenger train scheduled to run at over 200 km/h. For more information on the different types, see our [High Speed Train Page](#).

3.9. HEADWAY

This is the name given to the elapsed time between trains passing a fixed point in the same direction over the same track. It is usually expressed in minutes e.g. "trains were running at a 4-minute headway". Another way of expressing it is as trains per hour (tph).

A well run railway will conduct research to determine how many fare paying customers are likely to show up at various times of the day and will operate their trains to suit. See [Train Service Planning](#) below. In many instances the patronage numbers will show that it is possible to run trains at even intervals or at a given "headway". This may be at two hours for a long distance, main line route or two minutes for a metro.

Once established, the headway is used in calculating the number of trains required for a particular service, the train performance requirements and signalling requirements.

3.10. TERMINALS, LOOPS AND TURNBACKS

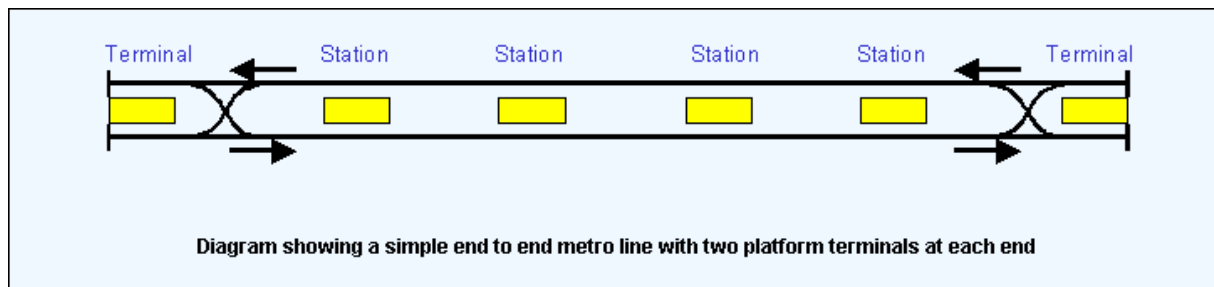

There are three ways of turning a train requiring to reverse its direction at the end of a trip. First a simple change of direction where a locomotive is placed at the other end of the train or, where driving cabs are available at both end of the train, can be achieved in a train in a single terminal platform with a track on either side as shown left.

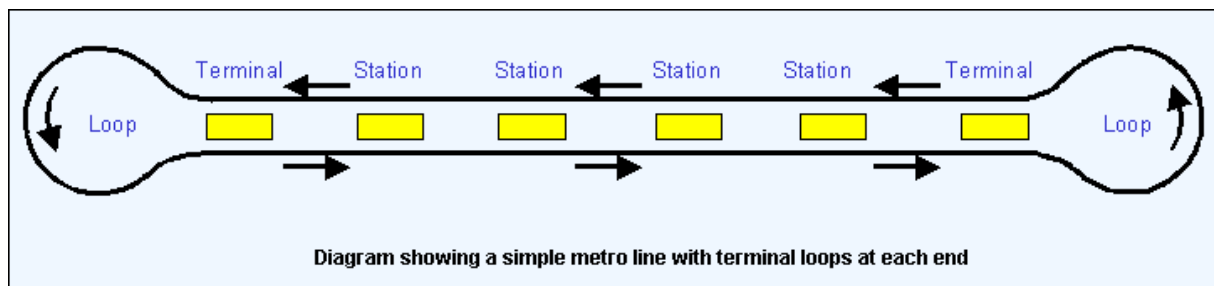

Second, you can drive the train around a loop track beyond the terminal station - provided you have the space to build the loop (diagram left).

Finally, you can provide a reversing track (or turnback, as it is called in the US). The train deposits arriving passengers in one platform and goes forward to the siding where it changes direction and then proceeds into a departure platform. In the diagram below, a single reversing track is shown at the left hand end while the double set of reversing tracks are shown at the right hand end. The latter is the usual option and can be seen in such places as Paris Metro and Tokyo Underground and London.

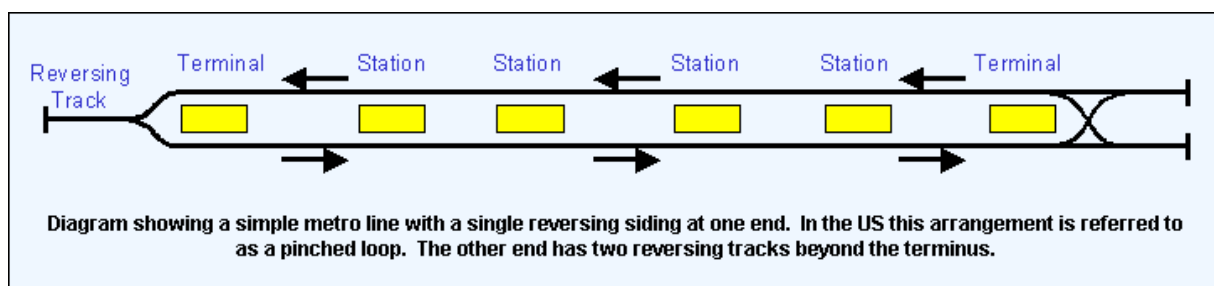

The first option a simple reversal procedure is the most popular since it uses least space and is reasonably quick. For the second option, tram or light rail operators who equipped their trains with a cab at one end only favour the loop. Some metro operators also use it, notably Paris and New York.

The third option is a reversing or turnback track as shown above (left hand end) but it is often used also when turning trains at a location mid-route. The siding is provided beyond the station between the main running lines and is connected to both, as shown below.

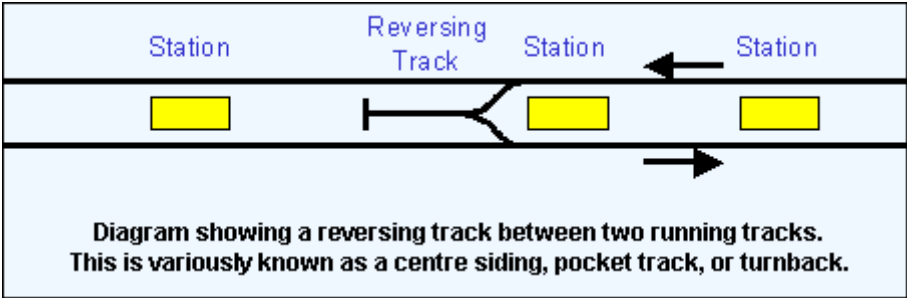

This solution is popular for urban and suburban systems where the inner section of a route has a requirement for a higher frequency service than the outer section.

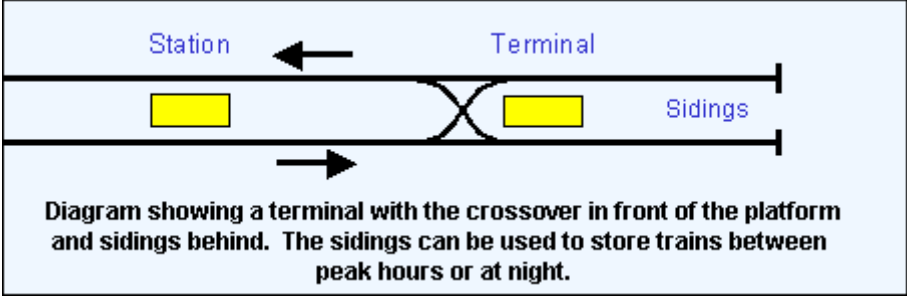

An alternative layout is where a two-track terminus has its tracks extended beyond the station (diagram left). This arrangement allows trains to be stored between the peak hours or at night. A defective train can be stored there until it can be repaired or sent back to the depot.

3.11. TRAIN SERVICE PLANNING

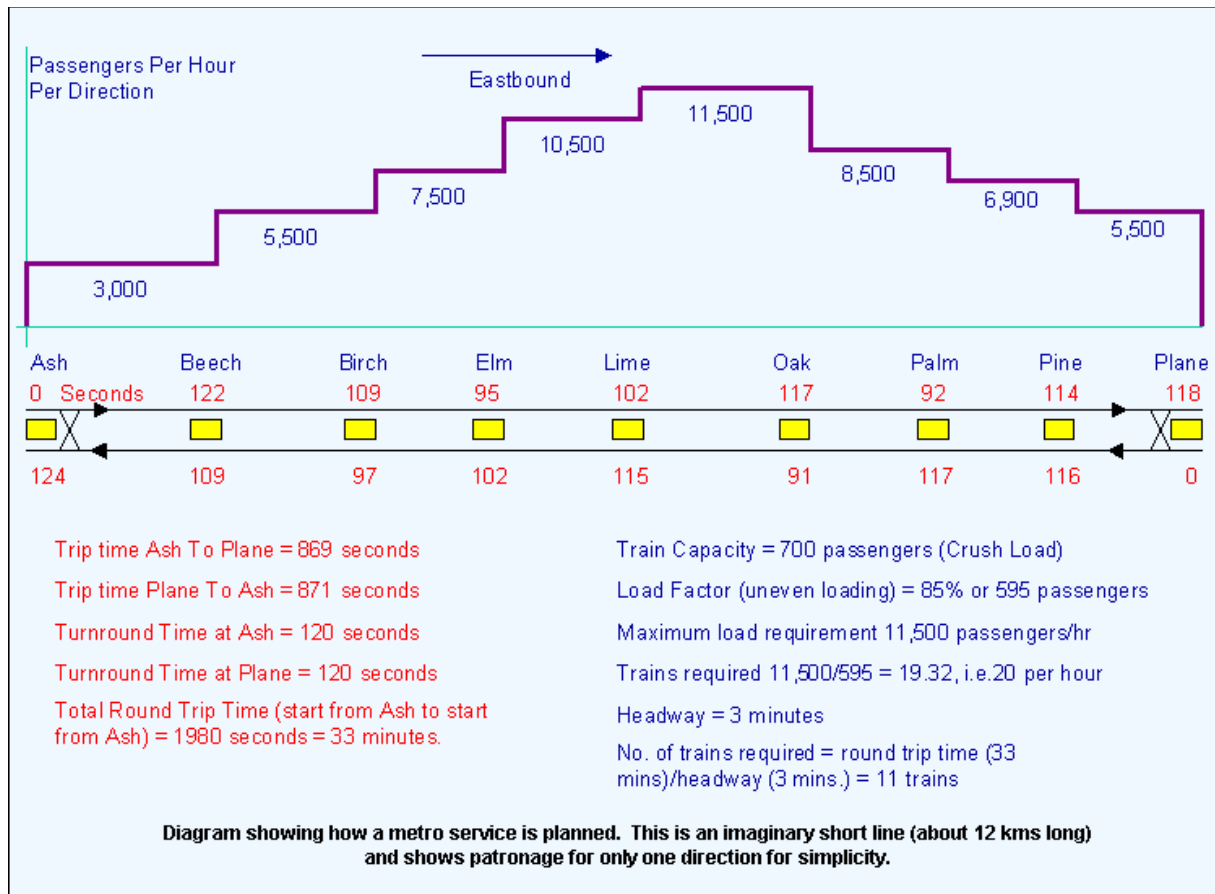

Here is an example of how a train service is planned for the peak hour of a short metro line. I suppose we could call it the Forest Line. The diagram below shows the elements involved in planning the train service.

First, you have to find out how many passengers will use the service. This involves assessing the numbers of people in a given area who will come to the station during each hour of the day and how they will get there. Some will walk, some will use a bus service (if there is a good connection) and some will drive, if there is cheap parking. For walkers, 500 to 800 metres is about the limit. Bus users will usually prefer to get a direct route and good integration of transport will allow bus routes to be organised to feed rail stations. Often, this process requires political commitment essential if the resources are to be used properly.

The next stage is to determine where the people want to go and when. For planning a new railway, this will be critical in deciding the best route. For existing lines, the development of the city may already have resulted from the routing of lines as it did in New York and London.

All of this "origin and destination" patronage data is fed into a computer program and the numbers for each station, each direction and during each hour are derived. Such programs are usually owned by consulting companies who are engaged to do the work or who licence the operator to use the software. The end result is a set of numbers for each station which show:

- Passengers boarding trains in each direction
- Passengers alighting from trains in each direction
- Passengers riding on trains between stations for each direction
- Passengers transferring from line to line at interchange stations (if any)

To allow the train service to be planned, the patronage study generates "passengers per hour per direction" (pphpd) as shown at the top of the diagram above. In our case, we see the passenger numbers travelling between each station but, for simplicity, only the eastbound direction. The "curve" generated will not necessarily look like the one above on a suburban route, where there is often a build up starting at one end of the line which carries on building up until the terminus is reached and the train is full (to bursting sometimes).

3.12. ROUND TRIP TIME

Once the patronage is determined, the train service has to be planned to carry the people who turn up. During the peak hours, this can be a lot of people. The frequency and number of trains required has to be calculated to match. First the run times are worked out, again by a computer program which includes the profile of the line (curves, gradients, station locations, dwell times at stations etc.) and the performance of the trains to be used. On heavily used lines, the program may incorporate the patronage figures to estimate the number of seconds each train has to stand or "dwell" at each station while loading and unloading takes place.

The diagram of our imaginary Forest line above shows in red the computer generated arrival times, in seconds, for a train running in each direction. Added together and with allowances for terminal standing times, the program will eventually provide a "round trip time", i.e the time it takes to run from one end of the line to the other, wait at the terminus, run back to the starting place and wait for the next round trip departure time.

In our example above, the run time from Ash to Plane is 869 seconds and the time back from Plane to Ash is 871 seconds. There is a 120 second dwell at each terminus to allow the train to change direction and load/unload passengers. This is actually longer than needed but we usually leave in a bit of extra time for delays known as "recovery time".

This time is also used to give a round trip time to balance the service interval. The end result our round trip time is 1980 seconds or 33 minutes.

3.13. TRAIN LOADING

The next step is the train loading. First we determine the train capacity - in our example above, I have used a capacity of 700 passengers. This is a fairly small number for a modern metro line but it is used in London for some lines and for those places which have short trains. At the other end of the scale, in Hong Kong, the Kowloon Canton Railway uses over 4000 passengers per train as the planned capacity of its 12 car trains. On one occasion, 363 passengers were counted travelling in one 24 metre car.

The density of passengers also determines the total capacity. In Western countries, the standing capacity of a train will often be calculated at 4 or 5 passengers per sq./m. In the Asian context, this number rises to 8 per sq./m. Europeans want lots of space, Asians don't seem to mind so much. The standing area is the free floor area of the car, i.e. where there are no seats.

We also decide on a load factor. No train will fill with passengers equally from end to end and passengers will not arrive at stations in steadily flowing numbers throughout each hour. So, a load factor is applied. In our case, it is 85%, a relatively small allowance used in Hong Kong because of the density of traffic. Larger allowances may be appropriate in other countries.

Now we know the capacity of the train ($700 * 85\% = 595$), it is a relatively simple sum to use the patronage data to determine the number of trains required each hour. You divide the numbers of passengers travelling along the busiest section of line (11,500) by the train capacity (595) to get trains per hour (19.32). We have to call it 20 trains per hour as we can't run 0.32 of a train. Twenty trains per hour is equivalent to a train every three minutes or a 3-minute headway.

3.14. ROLLING STOCK CALCULATIONS

We are now ready to calculate the rolling stock requirements. To find out how many trains are required to operate a regular interval passenger service, the following simple formula is applied:

Round trip time divided by the headway.

In our Forest Line example above, the round trip time is 33 minutes and the headway is 3 minutes, so we need 11 trains to operate this service during the hour when there are 11,500 passengers travelling over the busiest section of line. Some railways keep a "service spare" train on standby, in case a service train becomes defective or a disruption

to the service leaves a gap in the headway which needs to be filled temporarily. In this case we might plan to have 12 trains available for service and we will have to add one or two extra to cover maintenance requirements.

After the peak hours, the numbers of passengers will drop so the train service can be reduced to match. This will often mean, for a metro line, about a 40% or even a 50% reduction in the number of trains required. The planned train loading will usually be reduced during off-peak hours to allow a greater percentage of passengers to get seats, so the number of trains operating in off-peak hours may not match the patronage exactly as it does during the peak. Thus the load factor may be 50% or less.

3.15. ROLLING STOCK OPERATION

The stock required to operate a regular passenger service will be calculated as we have seen above and then a series of "diagrams" or working paths for each train will be designed. These will take into account:

- the location of the depot
- the location of other stabling points
- the frequency of exterior washing required
- the frequency of maintenance inspections
- other routes where the trains can be used

A train will have to be given time to move from its stabling point to the first station where it is required to pick up passengers. Time will also be allowed for its return to a stabling position, its "dispersal". Trains used to cover a weekday metro or commuter service present complicated patterns of use which look like this:

All day use: AM start to night finish

Peak only: AM start to AM finish; PM start to PM finish

Peak and evening: AM start to AM finish; PM start to Night finish

Mid-day: AM Start to PM finish

Each train will be used on one of the above patterns, of which there will be several varieties.

3.16. STOCK BALANCE

Rolling stock must be "balanced" at the end of the traffic day and timetables must be designed to allow this. "Balanced" means that any place where trains start from (a depot or sidings) must have an equal number of trains restored to that location at the end of the day. Here is an imaginary example:

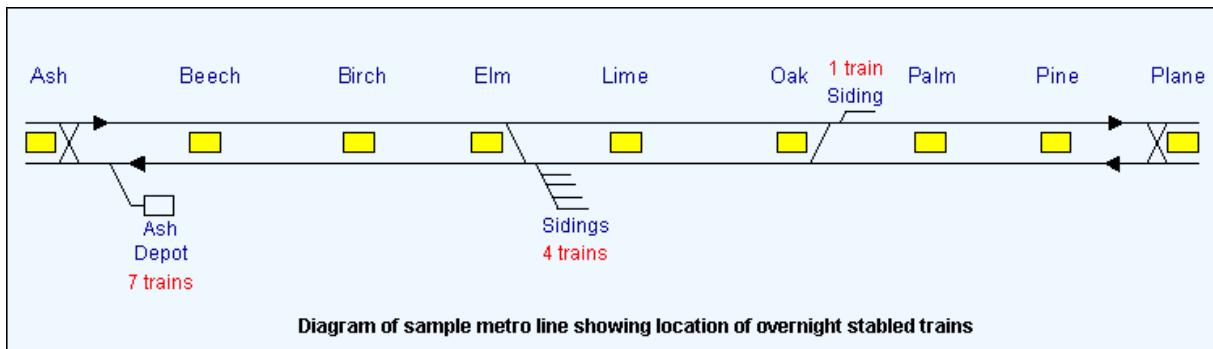

Our Forest Line (shown above) must provide 12 trains for the morning peak service each weekday - 11 for service and 1 spare. Of these, 7 are stabled at Ash Depot, 1 at Oak sidings and 4 at Elm sidings. One of the four at Elm will form the spare train. Therefore, by the time the last train has stabled after the close of traffic, 7 trains must have got back to Ash, 1 to Oak and 4 to Elm. The timetables must be designed this way and crew duties have to be arranged so that people are available to start these trains up each morning. If there is a train short at any location because it was left at the depot for any reason, a trip or two will be cancelled while the crew goes "away from home" to fetch it. This is what it means when you hear that the service is disrupted because "trains were in the wrong places" in the morning after a serious problem. It's the railwayman's version of a hangover.

Another point to realise is that it will be necessary to ensure that all trains return to depot within 2 or 3 days so that they can be washed and maintained. The balancing act must therefore ensure that the trains rotate through the depot in this 2-3 day period. Performing this balancing act is made easy by use of a technique known as diagramming. Before the diagrams are worked out, a timetable has to be prepared.

3.17. WORKING TIMETABLE

To show everyone concerned [sample here](#) how the train service will operate and where the trains will start and finish, a timetable must be drawn up. This is not the one the passengers see, it is a detailed one for staff. It shows all details of all train movements, including empty moves and times in and out of depots. It shows each train or trip identity and intermediate times for some, if not all stations. A sample, showing the start up of the Forest Line service in the early morning, can be seen on the [Working Timetable Page](#). This includes a train working summary and train diagrams.

3.18. TIMEKEEPING

This is such an old-fashioned word that many modern railway managements have forgotten its importance. In any business, the customer expects to get, at the very least,

what he is told he will get. If he is told his new car will be peacock blue, he will be very upset if an Italian red car is delivered. If he is told his train will arrive at 10:05 and it arrives at 10:10, he will also get upset. Any attempt at excuses will not remove the idea that he has now formed that the railway has not delivered. He is right. Whatever other things an operator at any level does, he should have timekeeping as his number one priority.

The first premise for timekeeping is to have clocks which tell the correct time. Systems for the central control of clocks to very accurate standards are widely available and are well worth the cost of installation and maintenance and can even be used and paid for as a marketing tool. Much of the cost can often be offset by advertising around the clock displays in public places. Times should also displayed in conjunction with train descriptions and arrival/departure information. Passengers should be able to set their watches by the station clock and know that it will always be correct. There is no excuse for railway clocks which do not tell the correct time.

The definition of "on time" has been elasticised in recent years, so much so that UK main line routes have classified on-time as any train which arrives within ten minutes of its timetabled time. This cannot be held up as a good customer relations exercise, nor good railway practice. Two minutes might be considered acceptable, if penalties were to be calculated in a contractual sense.

3.19. RECOVERY TIME

In order to "improve" timekeeping, railways have always provided recovery time in timetables. This is extra time, above that usually required for a train to complete its trip on time, allocated in case of a small delay or temporary speed restriction. We saw this in our example above where terminal time was extended a little. Unfortunately, it has become much abused in recent years in the UK and huge levels of recovery have been built in as much as 15% in some cases.

It does not make for good public relations when trains arrive at the outskirts of a city 10 minutes early and the passengers have to cool their heels in a stationary train knowing that they are only a few minutes travel time from their destination. Recovery time should be strictly limited and eliminated altogether when possible. It should not be used as an excuse for bad timekeeping.

3.20. TERMINAL OCCUPATION

Terminals are usually located in densely occupied areas and often date from an era when land was cheaper than it is now. Opportunities for expansion are limited so, for busy terminals, efficiency of operations is very important. It is essential that trains do not

occupy a platform for any longer than necessary to unload the arriving train and prepare it for departure.

Trains may require cleaning and/or reprovisioning whilst in a terminal platform, since the old practice of removing a train from the arriving station at the end of every trip, cleaning and restocking it for catering requirements and returning to service for a later trip, is inefficient. Toilets may also be drained and provided with clean water in terminals, if special facilities are provided. Diesel refuelling is generally done away from the passenger areas.

Track layouts at many terminals are complex and compact, due to the shortage of space. Flexibility of operation requires careful design of the layout and short run-in and run-out times. Restrictions due to signalled protection systems for dead ends will restrict train movements at peak times. A peak hour platform occupancy of more than four trains in the hour is unlikely for long distance services. Main line terminal operators would think they were doing well if they could get a platform utilisation of three, long distance EMU trains an hour in a dead end terminus like Victoria (London).

For metro operations, terminals are usually small and can accommodate a much higher frequency of trains. No dwell time is lost at peak times because of cleaning or catering. A two-platform terminus with a scissors crossover of suitable speed (as provided for Central, Hong Kong MTR) can allow a service of 34 trains per hour to be reversed if special crewing arrangements such as "stepping back" or "double-ending" are used.

3.21. STEPPING BACK

This is a crew change system used at a two-track, island platform terminal to reduce train turnaround time. When the first train arrives, the driver shuts down the cab and alights. Another, waiting driver, immediately enters the cab at the other (departure) end of the train and "opens up" the cab ready for departure. The first driver, meanwhile walks to the departure end of the opposite platform. When a train arrives in that platform, he enters the rear cab, waits for the arriving driver to shut down his cab and then prepares the rear cab for departure. When this is done the train is ready for departure. It should not be confused with double-ending. It has been used at, for example, Brixton (Victoria Line, London) and Central Station (Tsuen Wan Line, Hong Kong MTR) to good effect.

3.22. DOUBLE-ENDING

This is another method of turning trains quickly at a terminus. A train (assuming there are drivers' cabs at both ends) is provided with a driver at each end to give a rapid turnaround.

In the most common scenario, the train arrives at an arrival platform in a terminus with one driver in the leading cab. A second driver boards at the rear cab while the passengers are alighting from the train. The train is driven into a siding beyond the terminus by the first driver. As soon as he has stopped the train, he shuts down his cab controls and the second driver at the other end immediately opens up his cab. As soon as the route into the departure platform is cleared the second driver takes the train into the platform where passengers board and the other driver alights. This method is much favoured by the Paris Metro. Indications in cabs, such as an "Other Cab On" light, are usually provided to show when the other cab is switched out or "shut down", as they say.

Sometimes, the same procedure is used but the second driver joins the train at the station before the terminus and the change of direction is carried out in the terminal platform instead of in a siding. The disadvantage of this method is that boarding and alighting passengers are mixed on the same platform. This can defeat the object of double-ending, which is to reverse trains as quickly as possible under heavy traffic conditions.

And then there's the way it's done on the Toronto subway: each train carries two drivers at all times. The one who isn't driving operates the doors. This is normally done from a position 2 cars from the rear of the 6-car train, but it can be done from any cab. So if a quick turnaround is needed, the rear man just moves to the back of the train before the reversing station and the front driver closes the doors from what was the front cab before moving up two cars.

3.23. CREW NAMES

Driver

The person in front who (usually) controls the movements of the train itself. In the US known as the Engineer. Sometimes referred to as a Train Operator on metro systems or where One Person Operation is used. Also known as a "motorman" on some electric railways.

Conductor

Formerly (in the UK and some other places) the Guard. Provides assistance to the passengers and driver or other trainmen. Often used for fare collection and/or ticket checking. Used in emergency to provide train protection assistance. Some railways qualify guards/conductors for limited emergency driving.

Hogger

American nickname for driver.

Hostler

US name for a person working in an engine shed under the operating foreman. This is in turn derived from 'Ostler' who looked after the horses for the mail coaches, so it's a survival from English practice.

Fireman

Originally employed on steam locos to maintain steam pressure and assist the driver with the operation of the locomotive. Now retained on some railways as the driver's assistant, particularly on longer distance or freight operations. Called "second man" in the UK and "chauffeur" in France.

Second man

See [Fireman](#).

Trainman

Anyone who works on the train as a normal occupation.

3.24. CREW HOURS AND NUMBERS

The basic working day for industry world-wide is 8 hours. A break in the middle of this will usually be for at least 30 minutes. On a railway operating 18 to 24 hours a day, trainmen will have more flexible working conditions which might extend the working day to 12 hours with suitable rest breaks. Certainly, shift work is involved. Many countries have laws which limit working hours and which determine minimum rest periods.

Hours can now be a lot more flexible than used to be the case, since a lot of new agreements have been worked out between staff and managers of the new breed of commercially oriented railways. However, any disruption of the service can quickly disrupt the crewing as well as the train positions and action must be taken to adjust crew working with the available staff.

It is necessary to keep some spare staff on duty at all times. Any level between a minimum of 10% and a maximum of 25% for special circumstances might be considered necessary. One can be amazed at the levels of spare crews allocated on some railways.

For an even interval service with peak and off peak frequencies, the number of crews required to be employed can be calculated by the number of trains for the peak hour times a factor of 5. This allows for training, weekend cover, occasional days off, leave, compensatory leave for working public holidays, sickness, shunting duties and spare

crews. Individual totals will vary with the service provided and the conditions of employment and you might get that factor down to 4.5 or even 4 on smaller operations.

SIGNALLING PAGES INDEX

4.1. INTRODUCTION

Railway signalling is a complex and fascinating subject. This paper has a number of pages explaining the systems in use around the world ranging from old semaphore signals still used in the UK and elsewhere to modern electronic high capacity systems used by metros.

4.2. THE DEVELOPMENT AND PRINCIPLES OF UK SIGNALLING

4.2.1. Introduction

An outline of the history, development and basic principles of UK railway signalling, including multi-aspect signals.

4.2.2. Background

Signalling is one of the most important parts of the many which make up a railway system. Train movement safety depends on it and the control and management of trains depends on them. Over the years many signalling and train control systems have been evolved so that today a highly technical and complex industry has developed. Here is an attempt to explain, in simple terms, how railway signalling developed and how it really works, based on the UK standards.

4.2.3. Pioneer Signalling

Back in the 1830s and 40s in the very early days of railways there was no fixed signalling no system for informing the driver of the state of the line ahead. Trains were driven "on sight". Drivers had to keep their eyes open for any sign of a train in front so they could stop before hitting it. Very soon though, practical experience proved that there had to be some way of preventing trains running into each other. Several unpleasant accidents had shown that there was much difficulty in stopping a train within the driver's sighting distance. The problems were inexperience, bad brakes and the rather tenuous contact which exists on the railway between steel wheel and steel rail for traction and braking. The adhesion levels are much lower and vehicle weights much higher on railways than on roads and therefore trains need a much greater distance in which to stop than, say, a motor car travelling at the same speed. Even under the best conditions, it was (and is even more so nowadays with high speeds) extremely difficult to stop the train within the sighting distance of the driver.

4.2.4. The Time Interval System

In the early days of railways, it was thought that the easiest way to increase the train driver's stopping distance was to impose time intervals between trains. Most railways chose something like 10 minutes as a time interval. They only allowed a train to run at full speed 10 minutes after the previous one had left. They ran their trains at a 10 minute "headway" as it is called.

Red, yellow and green flags were used by "policemen" to show drivers how to proceed. A red flag was shown for the first five minutes after a train had departed. If a train arrived after 5 minutes, a yellow caution signal was shown to the driver. The full-speed green signal was only shown after the full 10 minutes had elapsed.

The "time interval system", in trying to use a headway to protect trains, created some serious problems. The most serious was that it was still inherently dangerous. Trains in those days were considerably less reliable than they are today and often broke down between stations. It also could not be guaranteed that the speed of the first train would be sufficient to prevent the second catching it up. The result was a series of spectacular rear-end collisions caused, in each case, because the driver believed he had a 10 minute gap ahead of him and had little or no warning if there was an erosion of that 10 minutes. Even if the time was reduced so much that he could see the train in front, he often did not have enough braking capacity to avoid a collision.

4.2.5. Line Capacity

Another serious problem, from the railways' point of view, was line capacity. Even if they could rely upon all trains not to make unscheduled stops and to travel at the same speed, the 10 minute time interval restricted the number of trains which could run per hour (in this case 6) over a given line. As they needed to run more trains, they gradually began to reduce the time between trains. As they reduced the time, or "headway", the number of trains per hour increased. At the same time too, the number of accidents increased. Eventually, they had to do something. The answer was fixed signalling.

4.2.6. Fixed Signalling

Even with the time interval system, the basic rule of signalling was to divide the track into sections and ensure that only one train was allowed in one section at one time. This is still good today. Each section (or block as it is often called) is protected by a fixed signal placed at its entrance for display to the driver of an approaching train. If the section is clear, e.g. there is no train in it, the signal will show a "Proceed" indication. For many years in Britain it was usually a raised semaphore arm. There are a few of these left around the country but nowadays it is usually a green light or "aspect", as the railways call it. If, however, the section is occupied by a train, the signal will show a

"Stop" indication, usually a red aspect. The next train will be made to wait until the train in front has cleared the section. This is the basis upon which all signalling systems are designed and operated.

Mechanical signals first appeared in the UK in 1841 and a signal box with levers controlling remote signals and points in 1860. Originally, the passage of each train through a section was tracked visually by the signaller. When the train had cleared his section, the signaller told the signal box on the approach side that his section was now clear and that he could, if required, "accept" another train. The messages between signal boxes were transmitted by a system of bell codes using the electric telegraph.

Compulsory use of the electric "block telegraph" to pass messages and signal interlocking, where points and signals were mechanically prevented from allowing conflicting movements to be set up, was introduced in the UK following the Regulation of Railways Act of 1889.

4.2.7. Distant Signals

The basic stop/go signal used to protect each section of the line was OK as long as the driver of an approaching train was able to see the signal in time to stop. This was rarely the case, so a system of "distant" signals was provided in many locations.

Distant signals were placed in such a position that the driver could stop in time if the next stop signal was at danger. Positioning depended on the visibility, curvature, maximum permitted line speed and a calculation of the train's ability to stop. In the UK, freight trains with reduced braking capacity (unfitted or partially fitted freights) were only allowed to run at restricted top speeds to allow for signal braking distances.

Originally, distant signals were semaphores, like the stop signals mentioned above. They showed a green light at night if their related stop signal was also green (or clear) and yellow if the stop signal was at red. The red-yellow-green pattern was adopted for colour light signals and eventually used to provide a more sophisticated form of train control.

4.2.8. Interlocking

Another safety feature introduced in the mid-19th Century was mechanical interlocking of points and signals. The purpose was to prevent the route for a train being set up and its protecting signal cleared if there was already another, conflicting route set up and the protecting signal for that route cleared. The interlocking was performed by a series of mechanically interacting rods connected to the signal operating levers in the signal box. The arrangement of the rods physically prevented conflicting moves being set up. As the systems developed, some larger signal cabins at complex junctions had huge frames of

interlocking levers, which gave the name "lever frame" to the row of operating levers in a signal box.

Eventually, by the time signal levers were being replaced by small (miniature) levers or push buttons, mechanical interlocking frames were superseded by relay interlockings. Electro-magnetic relays were used in series to ensure the safety of route setting at junctions. Complex "control tables" were drawn up to design the way in which these relays would interact and to ensure safety and integrity.

4.2.9. Blocks

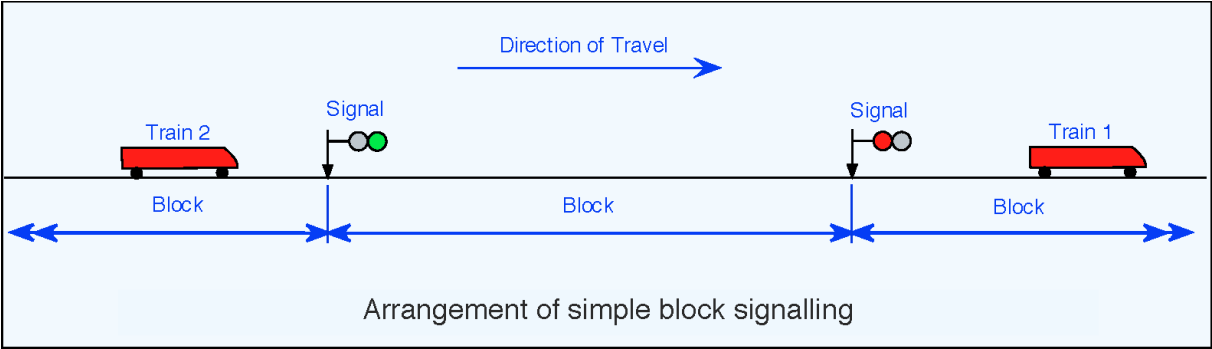

Fig. 1: Schematic of signal block section. When a block is unoccupied, the signal protecting it will show green. If a block is occupied, the signal protecting it will show red.

Railways are provided with signalling primarily to ensure that there is always enough space between trains to allow one to stop before it hits the one in front. This is achieved by dividing each track into sections or "blocks". Each block is protected by a signal placed at its entrance. If the block is occupied by a train, the signal will display a red "aspect" as we call it, to tell the train to stop. If the section is clear, the signal can show a green or "proceed" aspect.

The simplified diagram above shows the basic principle of the block. The block occupied by Train 1 is protected by the red signal at the entrance to the block. The block behind is clear of trains and a green signal will allow Train 2 to enter this block. This enforces the basic rule or railway signalling that says only one train is allowed onto one block at any one time.

4.2.10. The Track Circuit

Nowadays for signalling purposes, trains are monitored automatically by means of "track circuits". Track circuits were first tried in the US in the 1890s and soon afterwards appeared in Britain. London Underground was the first large-scale user of them in 1904-6.

Low voltage currents applied to the rails cause the signal, via a series of relays (originally) or electronics (more recently) to show a "proceed" aspect. The current flow will be interrupted by the presence of the wheels of a train. Such interruption will cause the signal protecting that section to show a "stop" command. Any other cause of current interruption will also cause a "stop" signal to show. Such a system means that a failure gives a red aspect a stop signal. The system is sometimes referred to as "fail safe" or "vital". A "proceed" signal will only be displayed if the current does flow. Most European main lines with moderate or heavy traffic are equipped with colour light signals operated automatically or semi-automatically by track circuits.

4.2.11. Track Circuit - Block Unoccupied

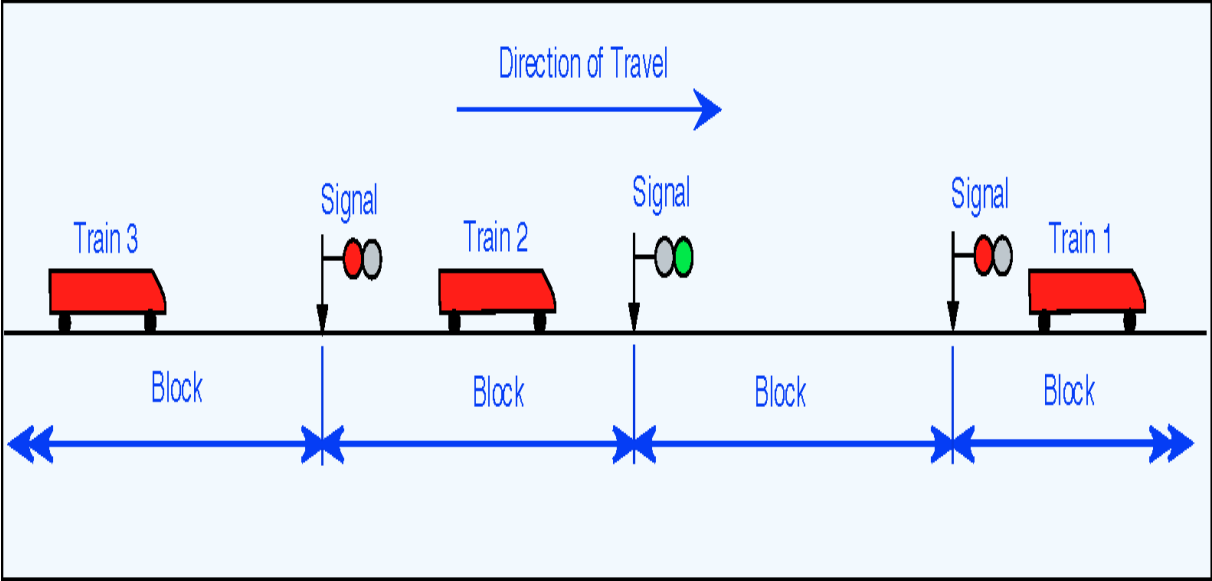

Fig. 2: This diagram shows how the track circuit is applied to a section or block of track. A low voltage from a battery is applied to one of the running rails in the block and returned via the other. A relay at the entrance to the section detects the voltage and energises to connect a separate supply to the green lamp of the signal.

4.2.12. Track Circuit - Block Occupied

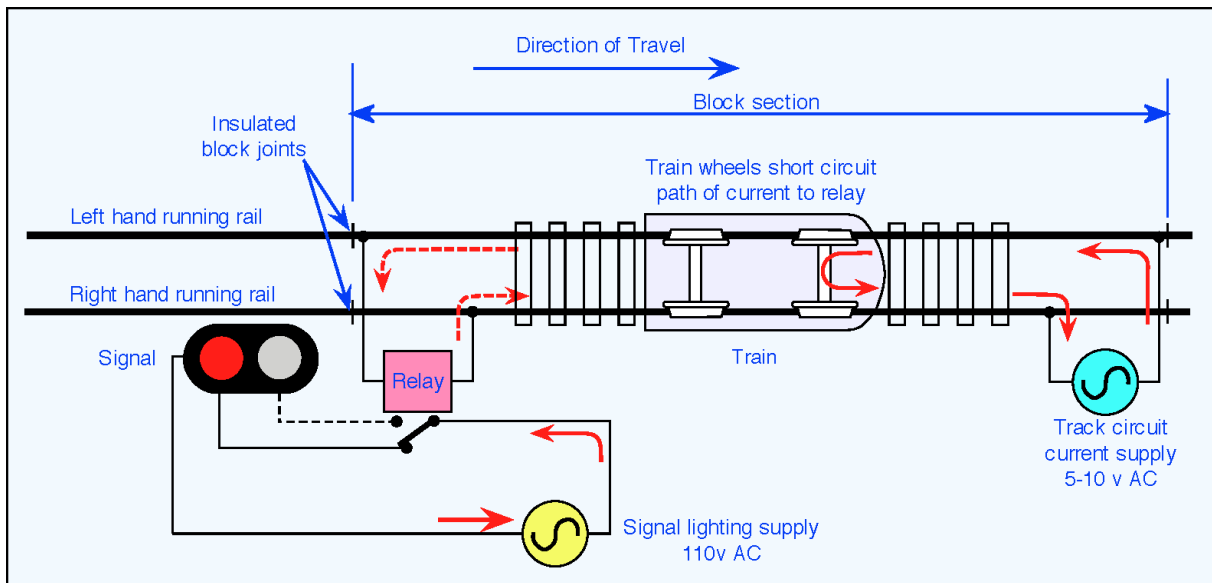

Fig. 3: When a train enters the block (above), the leading wheelset short circuits the current, which causes the relay to de-energise and drop the contact so that the signal lamp supply circuit now activates the red signal lamp. The system is "fail-safe", or "vital" as it is sometimes called, because any break in the circuit will cause a danger signal to be displayed.

The above is a simplified description of the track circuit. The reality is somewhat more complex. A block section is normally separated electrically from its neighbouring sections by insulated joints in the rails. However, more recent installations use electronics to allow jointless track circuits. Also, some areas have additional circuits which allow the signals to be manually held at red from a signal box or control centre, even if the section is clear. These are known as semi-automatic signals. Even more complexity is required at junctions.

4.2.13. Multi-Aspect Signals

The basic, two-aspect, red/green signal is fine for lower speed operation but for anything over about 50 km/h the driver of a train needs a warning of a red signal ahead to give him room to stop. In the UK, this led to the idea of caution signals (originally called "distant" signals when they were mechanically operated semaphore arms) placed far enough back from the signal protecting the entrance to the block to give the driver a warning and a safe braking distance in which to stop. When this was developed for track circuited signalling, the caution signal was provided a block further back from the stop signal. Each signal would now show a red, yellow or green aspect - a multi-aspect signal.

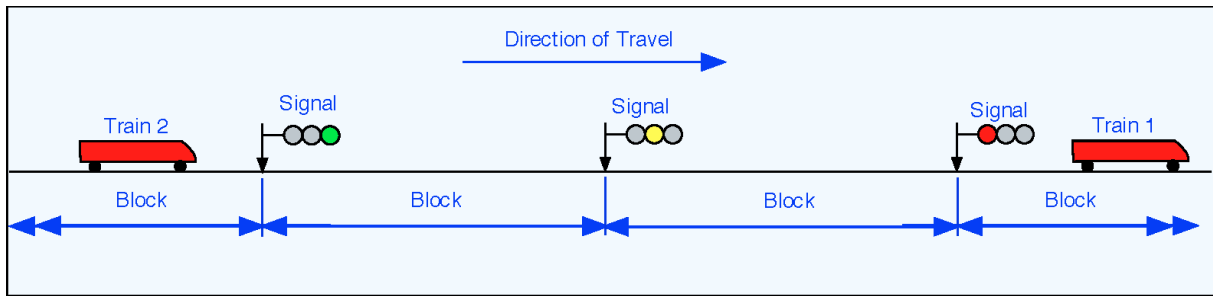

Fig. 4: Schematic of 3-aspect signalled route showing the additional yellow aspect provided to allow earlier warnings and thus higher speed operation.

This diagram (Fig. 4) shows a line with 3-aspect signals. The block occupied by Train 1 is protected by the red signal at the entrance to the block. The block behind is clear of trains but a yellow signal provides advanced warning of the red aspect ahead. This block provides the safe braking distance for Train 2. The next block in rear is also clear of trains and shows a green signal. The driver of Train 2 sees the green signal and knows he has at least two clear blocks ahead of him and can maintain the maximum allowed speed over this line until he sees the yellow.

4.2.14. Four-Aspect Signalling

The multi-aspect signalling commonly used in the UK today is a 4-aspect system. It works similarly to the 3-aspect system except that two warnings are provided before a red signal, a double yellow and a single yellow. This has two purposes. First, it provides early warnings of a red signal for higher speed trains or it can allow better track occupancy by shortening the length of the blocks. The high speed trains have advanced warning of red signals while the slower speed trains can run closer together at 50 km/h or so under "double yellows".

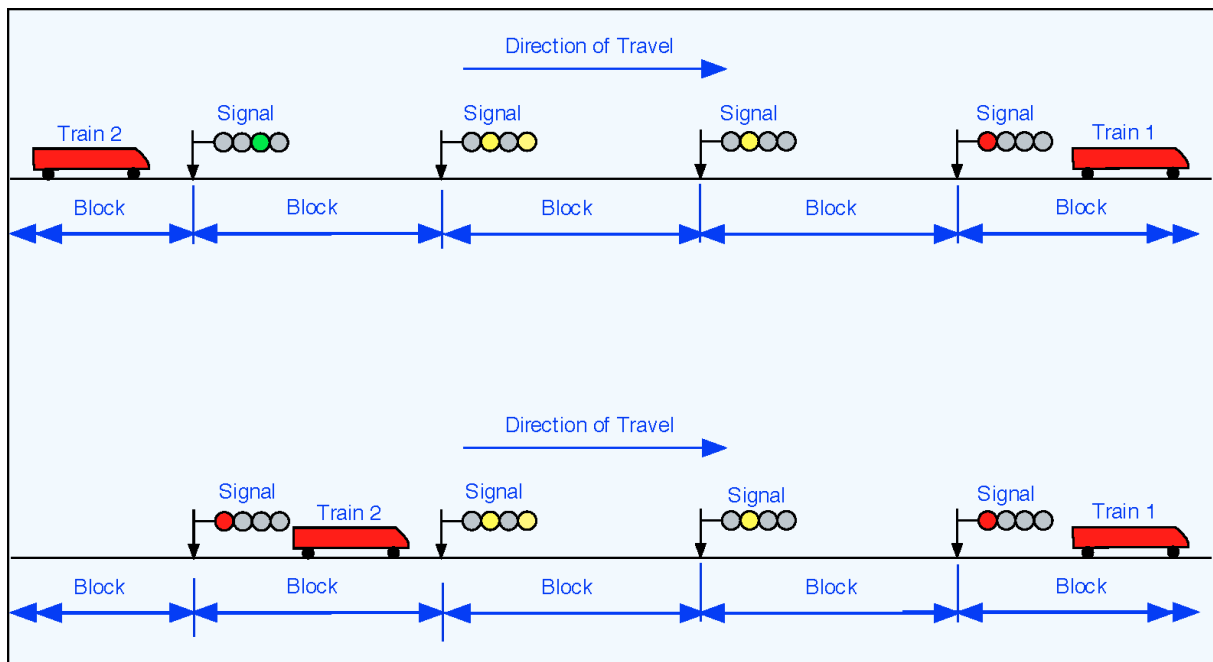

Fig. 5: Schematic of 4-aspect signalled route showing the double-yellow aspect.

This diagram shows four-aspect signals with (in the upper diagram) a high speed train with three clear blocks ahead of it and (lower diagram) a slower train with two clear blocks ahead of it. The lower speed trains can run closer together so more trains can be operated over a given section of line.

4.2.15. A Safe Braking Distance

The foregoing description of signalling has so far only looked at the concept of warning or enforcement of restrictive signal indications. It has not yet taken into account braking distance or headway. First, there is the problem of braking distances. As we have already seen, a train cannot stop dead. An Inter City train travelling at 100 mph (160 km/hr) will take more than a mile to stop. Even for a signalling system with enforcement (ATP) like the London Underground, as described so far there is a risk that a train could pass a stop signal, then be stopped by the ATP enforcement system and still hit the train in front. This situation could occur if the train in front was standing just ahead of the signal protecting it. The problem has long been recognised and can be overcome by the provision of a space for the train to stop in, an "overlap".

4.2.16. The Overlap

In its simplest form, the "overlap" is a distance allowed for the train to stop in should it pass a signal showing a stop aspect. It is provided by positioning the signal some way before the entrance to the section it is protecting.

On BR, because it is impossible to calculate all the various braking distances of different types of trains and because it is impossible to predict when a driver might react to a stop signal, a fixed value of 200 yards (185 metres) is used. On metros which use ATP

systems, the distance is calculated by a precise formula based on the known braking capacity of the metro train, the gradient at the location concerned, the maximum possible speed of the trains using that section, an allowance for the sighting of the signal by the driver and a small margin. The result of the calculation is called the "safe braking distance". The overlap incorporates this safe braking distance

4.3. TRAIN PROTECTION IN THE UK

4.3.1. Background

In spite of the excellent safety record of railways as a means of transportation, there have been occasions when drivers have allowed their train to pass a point where they should have stopped. Many of these incidents have resulted in collisions, some involving loss of life and most involving damage to equipment or property. Most incidents are the result of a driver failing to ensure that his train stops at a stop signal. In the UK, this has become known as SPAD or Signal Passed At Danger.

Such incidents have occurred on railways ever since they began in the early 19th century and various systems have been introduced to try to prevent them. These have taken the form of both warning and train stop systems. In the UK, a warning system is used on most main lines. An alarm sounds in the driver's cab whenever a train approaches a caution or stop signal. If the driver fails to acknowledge the alarm, the train brakes are applied. The system is called AWS (Automatic Warning System)

4.3.2. AWS - Automatic Warning System

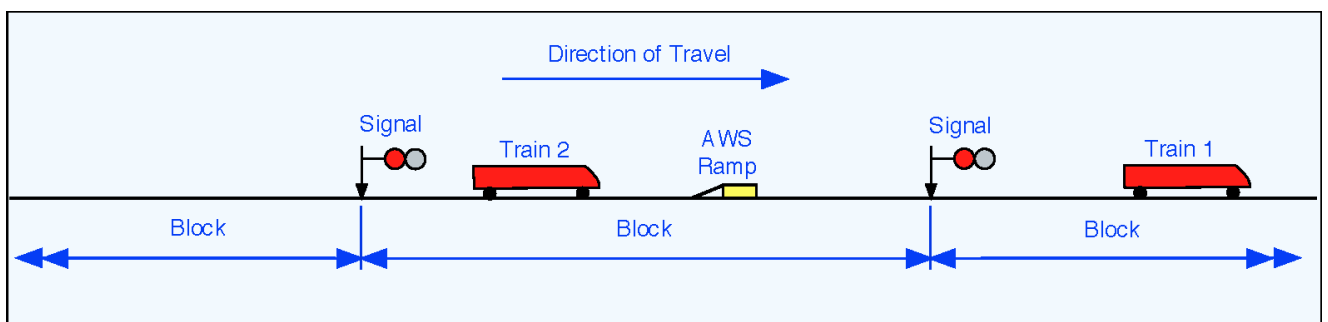

Fig 1: Schematic showing arrangement of AWS Ramp on the approach to a signal.

It was realised (even before WW1) that some sort of automatic and enforceable warning was needed. This (after a number of experiments and some complete systems had been tried) eventually took the form of a track mounted, non-contact inductor which became known as AWS (Automatic Warning System). The AWS "ramp" as the inductor is known, is placed about 185 metres (200 yards) on the approach side of the signal (diagram, left).

The AWS ramp is placed between the rails so that a detector on the train will pass over it and receive a signal. The ramp will thus warn the driver of the status of the signal. The French railways use a similar system called "the Crocodile", the Germans, the "Indusi".

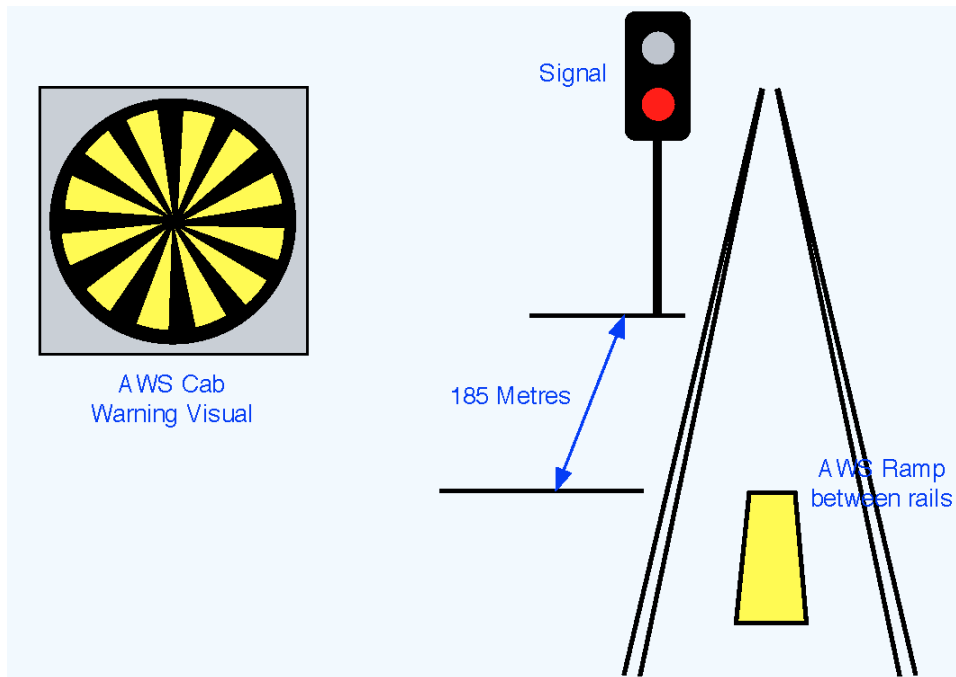

Fig 2: Schematic showing position of AWS Ramp in the track on the approach to a signal.

The AWS ramp contains a pair of magnets, the first permanent, the second an electro-magnet linked to the signal to provide an indication of the aspect. The ramp is placed between the rails so that a detector on the train can receive the indication data. The more observant passenger on a station platform can often see the ramps between the rails. They are usually a dirty yellow.



In operation, the train first passes over the permanent magnet and the on-board receiver sets up a trigger for a brake application. Next it passes over the electro-magnet. If the signal is green the electro-magnet is energised, the brake trigger is disarmed, a chime or bell rings in the driver's cab and a black indicator disc is displayed. The driver takes no action. If the signal is yellow or red, as shown above (Fig. 2), the electro-magnet is de-energised, so a siren sounds in the cab and the disc becomes black and yellow. The driver must "cancel" the warning, otherwise the automatic application of the train brakes is triggered. The photo (left) shows the AWS "ramp", as the equipment is called, mounted at the approach to a signal.

4.3.3. Enforcement

It can be seen from the above that the British AWS allows the driver to cancel a warning as he approaches a signal. This means that, if he cancels the warning and still fails to stop, his train could collide with the train in front. There have been some well documented examples of this in the recent past. The only way of preventing this situation is by adopting a system of enforcement.

A very simple system of enforcement is used by the London Underground. It is called the trainstop. It is a mechanical arm fitted to the track next to each signal. When the signal is red, the arm is raised and will physically hit a trip device fitted to each train should the train pass the signal. This causes the train to stop by cutting off the power to the motors and applying an emergency brake application. When the signal shows a proceed indication the trainstop arm is lowered and the train can pass unhindered. The system is a simple form of Automatic Train Protection (ATP). It was first used in the UK in 1904, the idea having been imported from the US. It has been used by a number of other systems around the world. The modern versions occur in various Automatic Train Protection (ATP) systems available today which are based on electronics.

4.3.4. TPWS

In spite of the installation of AWS over most of the UK's main line railways, there has been a gradual increase in the number of signals passed at danger (SPADs) in recent years and some serious collisions as a result. In an attempt to reduce these, a number of suggestions were made to reduce the impact (pun intended) of SPADs. One of these is the Train Protection and Warning System or TPWS, which has now become standard across the UK.

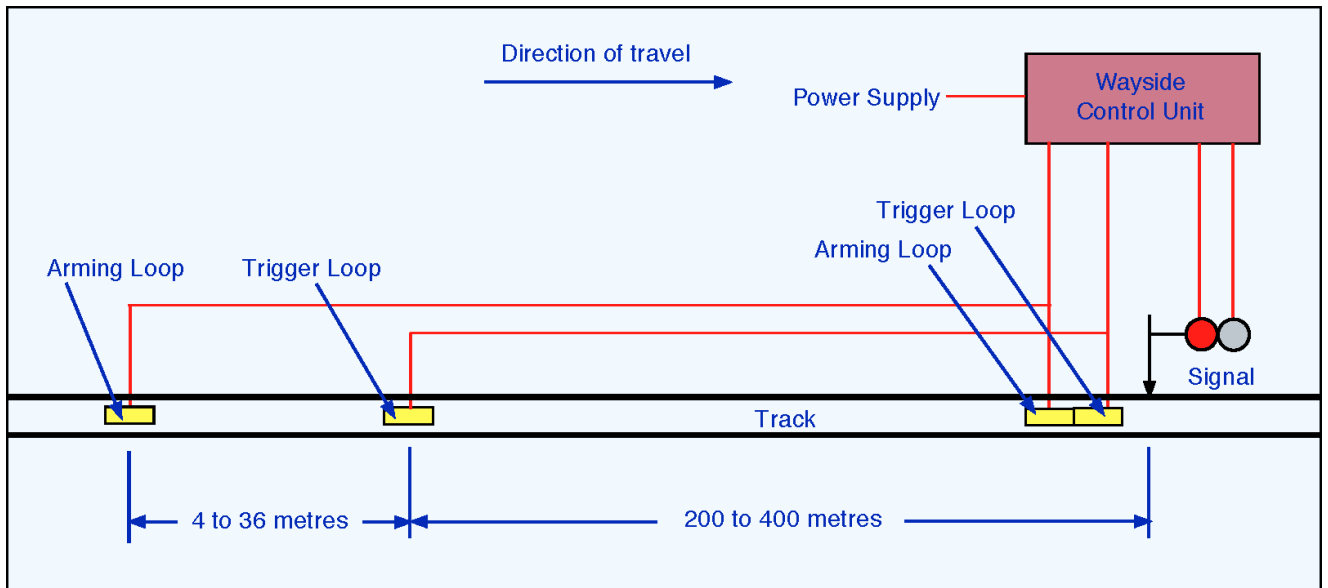

Fig. 3: Schematic of TPWS setup on the approach to a stop signal. The Arming Loop switches on a timer and the Trigger Loop assesses the time elapsed to determine the speed of the train. If the time is too short, showing the speed is too high, the trigger will activate the train brakes.

The idea behind TPWS is that, if a train approaches a stop signal showing a danger aspect at too high a speed to enable it to stop at the signal, it will be forced to stop, regardless of any action (or inaction) by the driver. The equipment is arranged as shown left.

For each signal equipped with TPWS, two pairs of electronic loops are placed between the rails, one pair at the signal itself, the other pair some 200 to 450 metres on the approach side of the signal. Each pair consists of, first an arming loop and secondly, a trigger loop. The loops are activated if the signal is showing a stop aspect.



The pair of approach loops first met by the train at 400 to 200 metres before the signal, are set between 4 and 36 metres apart. When the train passes over the arming loop, an on-board timer is switched on to detect the elapsed time while the train passes the distance between the arming loop and the trigger loop. This time period provides a speed test. If the test indicates the train is travelling too fast, a

full brake application will be initiated. In case the train passes the speed test successfully at the first pair of loops but then fails to stop at the signal, the second set of loops at the signal will cause a brake application. In this case, both loops are together (see photo -

right) so that, if a train passes over them, the time elapsed will be so short that the brake application will be initiated at any speed.

4.3.5. What TPWS Does

TPWS has certain features which allow it to provide an additional level of safety over the existing AWS system but it has certain limitations and does not provide the absolute safety of a full [Automatic Train Protection \(ATP\)](#) system. What TPWS does is reduce the speed at which a train approaches a stop signal if the driver fails to get the speed of the train under control to allow him to stop at the signal. If the approach speed is too fast, TPWS will apply a full brake but the train may still overrun the signal. Fortunately, since the train is already braking and there is usually a "cushion" of 200 yards (183 metres) between the signal and the block it is protecting, there will be a much reduced risk of damage (human and propertywise) if the train hits anything. With a possible total distance of 2000 feet (about 600 m) between the brake initiation and the block entrance, trains "hitting" the first loops at up to 120 km/h (75mph) could be stopped safely.

TPWS is also provided at many (about 3000) Permanent Speed Restrictions (PSRs) to ensure that a train does not pass through a restricted section of line (say one with a sharp curve) at too high a speed. However, there have been a number of issues related to the use of TPWS in these cases. Drivers have complained that, although they were approaching the PSR at a speed which would allow the train to run at the correct speed within the restriction, they still got stopped by the TPWS "speed trap". This has led to some vigorous discussions between Network Rail, the train operating companies and the HSE.

An add-on to TPWS, called TPWS+ is provided at certain signals where train speeds are above 100 mph or 160km/h.

4.3.6. What TPWS Does Not Do

The safety effects of TPWS are limited by the fact that it is provided only for stop signals and that it cannot have any effect at caution signals. This means that there is a range of speeds at the higher level which will be excluded from full protection. In spite of this, it is suggested in published data that 60% of accidents due to SPADs will be prevented by the installation of TPWS at critical locations. This is achieved, it is said, at 10% of the installation costs of a full ATP system.

TPWS does not replace the existing AWS system. AWS is retained, so the driver will still get the warnings advising him of adverse signals. The TPWS equipment is designed to interface with the existing on-board wiring of trains so that it can be fitted quickly.

4.3.7. ATP (Automatic Train Protection) or TPWS

An increasing number of railways around the world are provided with ATP. ATP provides either a continuous or regular update of speed monitoring for each train and causes the brakes to apply if the driver fails to bring the speed within the required profile. There are various versions of ATP, some of which are described in our [Metro Signalling and ATP](#) page. ATP is popular on metros because of the very dense train services provided and because many run for long distances in tunnels. New, or newly upgraded high speed railways also have ATP.

The main reason why existing railways have been slow to introduce ATP is because of the costs and because it is difficult to allow for the variable braking capabilities of different types of trains, in particular, freight trains. The varying size and braking abilities of freight trains means that data input for the on-board ATP computer has to be manual. Railway administrations have been reluctant to invest large sums of money in a safety system which, because of the possibility of manual input error, does not offer a total "vital" safety coverage. For the UK, the high price of full ATP has caused it to be rejected as the system-wide standard signalling safety system, so TPWS has been adopted as the nearest suitable and more cost-effective alternative.

4.3.8. ERTMS

For European main line railways, the required form of train protection on those routes intended for interoperable services (the TEN routes) will be based on the architecture of ERTMS, the European Rail Traffic Management System. The signalling part of ERTMS is called ETCS - European Train Control System. The system has been developed across Europe and installed on selected routes in a number of countries. In the UK, a trial version has been installed on the Cambrian route in Wales and the first section from Pwllheli to Harlech was commissioned on the 28th October 2010. A useful description of the trial installation has been published by the Rail Engineer magazine [here](#). The ERTMS website has a description of the [basic technical structure and operation](#).

4.3.9. Comment

It is worth saying here that passing a signal at danger is something that every driver fears and tries to avoid but knows that, in a moment of distraction or in an attempt to make up time, it will happen to him one day. The normal pattern of such incidents is that the signal (and, in case you ask, yes, it has happened to me) is passed because of an error of judgement in braking, not due to ignoring a signal aspect. Usually, such overruns are not at high speed and the overlap beyond the signal absorbs it so that the train does not enter the occupied block. Sometimes and more seriously, the overrun occurs when the driver misses a caution and cancels an AWS warning. Several collisions have occurred as a result of this and it is something which TPWS will almost eliminate.

One area where TPWS has turned out to be more trouble than it prevents is at terminal platforms. A too restrictive 10 mph speed limit on the approach to the buffers in a terminal platform has meant an increase in the time for a train to clear the routes into the terminus. At many termini in the UK, this has seriously affected capacity at peak times and has the effect of reducing the number of trains arriving and departing. This will lead to a reduction in service or will reduce recovery capability.

Since modern rolling stock is built to a high standard of crashworthiness, a 20 mph buffer stop collision is unlikely to cause a serious deformation of a vehicle. Any speed restriction below this level for arriving trains causes a severe operating restriction on the terminus with little apparent safety benefit. There should be an immediate increase in terminal entry speed to 20 mph. Some terminals now have a 15 mph limit.

4.4. BRITISH SIGNALLING - WHAT THE DRIVER SEES

4.4.1. Introduction

This page describes the types of signals seen on British railways and their meanings. Semaphore and colour light signals are included.

4.4.2. Semaphore Signals

During the 19th century a system of mechanically operated semaphore signals was developed for Britain's railways. Although there were many different and independent railway companies, by the early 20th century, signals were generally standardised, but with some variations in style and appearance. Many semaphore signals have survived to this day, although they are becoming rarer. However, there are some excellent examples still to be seen on the heritage lines operated by preservation groups all over the country.

4.4.3. Semaphore Signal Parts

First, a diagram of a semaphore signal and its main parts. The signal is normally placed on the left side of the track with the arm directed over the offside. The standard arm is red with a white vertical band, although some older signals were plain red. To allow the signal indication to be seen at night, the arm is fitted with two lenses, duplicating the indication displayed. The lenses are illuminated from behind, originally by oil lamps, later by electric lamps.

The signal is mounted on a signal post, originally wooden but later lattice steelwork, pressed steel, old rail, and concrete appeared at various places. Some railways could be recognised from the design of their signal posts, the ones from the Victorian era having

elaborate finials and other attachments.

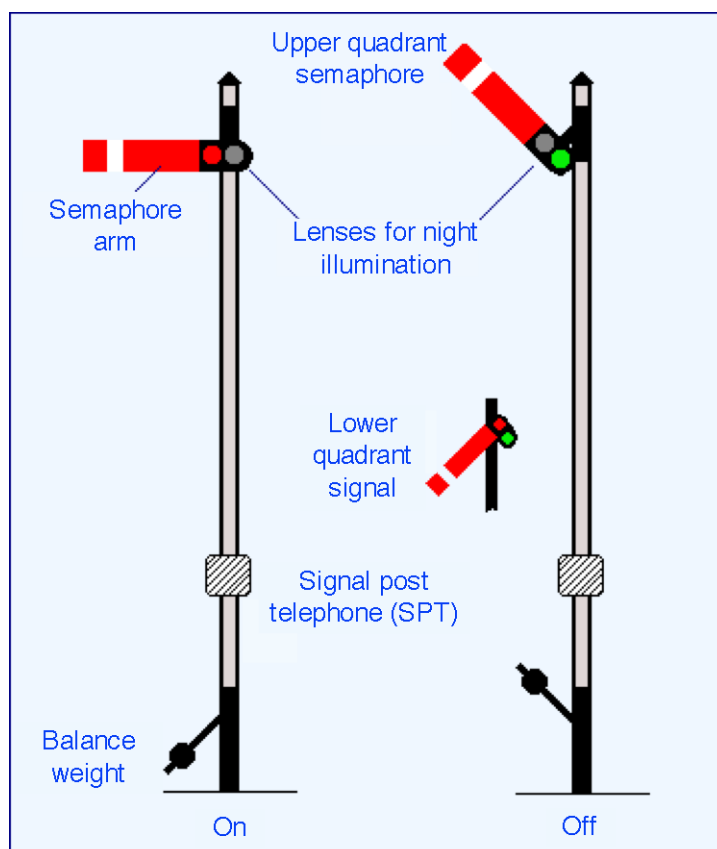

Signal posts were often tall, so that the signal could be seen clear of engine smoke and from a distance. It was also intended that the guard could see the signal from the rear of the train as it was part of his duties to check signal indications.

The post is normally fitted with a ladder, originally to allow access to the oil lamps and now retained

for maintenance. The post is often provided with a telephone linked to the signal box. The telephone is contained in a small box with black and white diagonal stripes on the cover. The driver or other train crew can use this to alert the signaller of the presence of the train and to enquire why the signal remains "at danger", as we say in the trade.

The arm of the signal is displayed in a horizontal position to show the "stop" or "danger" indication. The red lens is illuminated. The indication to the driver is "stop" until either the signal indication gives "proceed" or he is given verbal authority by the signaller to proceed.

To give a "proceed" indication, the semaphore arm is raised to an angle of 45° as shown in the diagram. The movement of the arm causes the green lens to replace the red lens in front of the lamp. A "proceed" indication tells the driver that he may proceed at normal speed for that section of line, subject to any speed restrictions displayed and according to the speed limit of the particular type of train he is driving. Unlike many other countries, British signals do not give a speed indication to the driver.

Some signals showed "proceed" by lowering the arm instead of raising it. This type of signal is called a "lower quadrant semaphore", (shown as an inset in the diagram) as opposed to the more usual "upper quadrant" type. The lower quadrant type was much favoured by the Great Western Railway but eschewed by others following an accident caused by a stop signal showing a proceed indication because it drooped with the weight of snow resting on the arm. The GWR maintained they had never had an accident caused by this type of signal so they weren't about to change them now. Anyway, they didn't want the expense.

One final part of the signal mechanism is the balance weight. It is linked to the cable which operates the signal. The cable, of course, is connected to the lever in the signal box which operates that particular signal. The purpose of the balance weight is to pull back the signal wire when the lever is replaced in the frame by the signaller.

4.4.4. Types of Semaphore Signal

The following series of diagrams, with descriptions, shows the various types of semaphore signals seen in the UK.

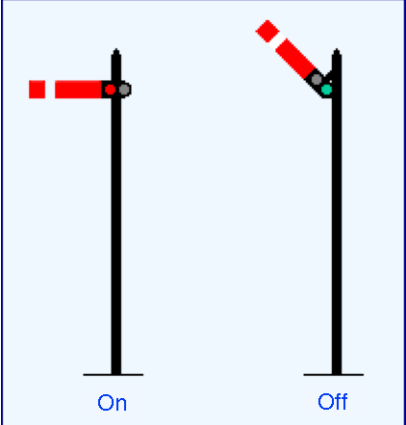

A Home Signal or Starting Signal (left) is the stop signal described above. It is placed at the entrance to a block and, when showing "stop", the train is forbidden to enter the block. When a signal shows a stop or other restrictive

indication, it is said to be "on". A signal showing a proceed indication is said to be "off".

Traditionally, at a station, each track would have two stop signals. One, protecting the entrance to the block, was called the Home Signal. The other, protecting the exit towards the next station or signal box, was called the Starting Signal or Starter.

As mentioned above, this is a stop signal showing a proceed indication - it is "off". The train may enter the block at normal speed. In effect, this means the maximum speed applicable to this section of line and the type of train.

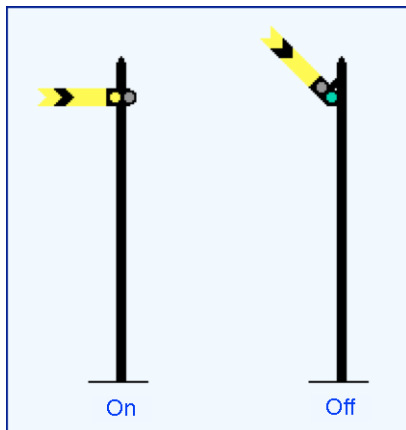

To give advanced warning of the indication of a stop signal, a "distant" signal is sometimes provided (left). This operates in the same way as the stop signal but gives either a "caution" indication (it is said to be "on"), shown on the left, or a proceed indication, on the right. If the distant is "on", a yellow light shows at night. The distant signal showing "on" tells the driver that the next stop signal is also "on" and that he will have to stop there. The distant signal was, if possible, located $\frac{3}{4}$ mile

(1200 metres) before the stop signal. A single distant signal will often provide a warning for both home and starting signals at a station.

The distant shows a yellow (on) or green (off) light at night. Remember that the distant signal normally refers to more than one consecutive stop signal ahead. Thus, when the distant is off, the driver knows that all the relevant stop signals are off too. Each stop signal does not have its own distant signal in rear.

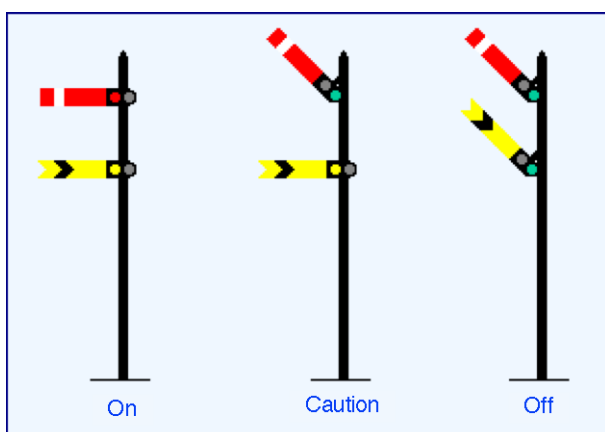

Where blocks were short or stations close together, the distant signal was often placed on the same post at the previous stop signal. The driver now has two indications, one from the stop signal protecting the entrance to the block, the other from the distant for the next stop signal. To avoid confusion, if the stop signal is "on", the distant will also be "on",

even if the next stop signal happens to be "off". This is achieved by linking the two signals mechanically - a system known as "slotting". At night, the driver will see two lights, a red over a yellow. The red always takes precedence.

At a signal post with home and distant together, there will be occasions when the block immediately ahead is free and the train may enter but the next block may be occupied. In this case the driver will see the stop signal "off" and the distant "on" as shown here. At night, he will see green over yellow. This shows him he may proceed into the block but that the next stop signal is "on" and he must stop there.

The third indication for a stop and distant signal is where both are "off". The driver is being told both this block and the next are free and he may proceed at normal speed. At night he will see green over green.

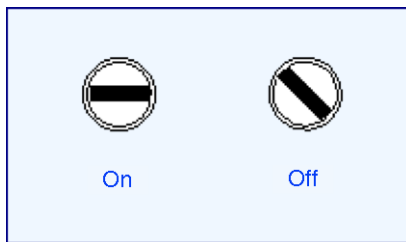

In some very restricted locations, a repeating signal is provided, often referred to as a "banner" signal (left). It is a black band on a white disc which repeats the position of the semaphore arm.

4.4.5. Junction Signals

At junctions, it has always been the custom in the UK to show a driver the route set, not just to show the permitted speed as usual elsewhere. In semaphore signalling, it was normal to split the signals as shown below.

Junction Signals

See below (a). This pair of stop signals protects a pair of diverging routes. The lower signal is "off", indicating that the diverging route to the left of the two is set and locked and the train may proceed along that route. The position of the two semaphore arms was often arranged so that one was lower than the other to indicate a slower route, usually because of a curve.

Splitting Distant

See below (b). Junction signals also have an equivalent distant set up. These are always referred to as "splitting distant". They provide advance warning of the position of the junction signals and they operate in the same way as regular distant.

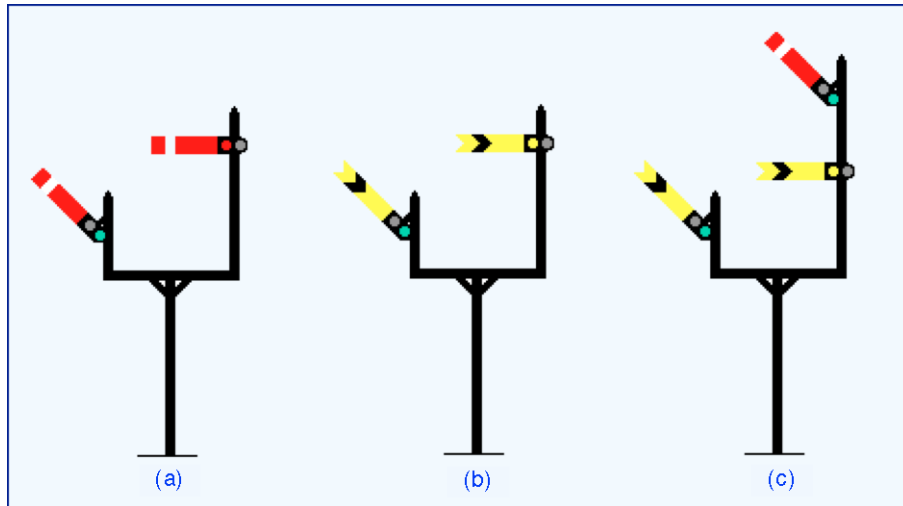

There are also combined versions of the splitting distant (c) where a stop signal is placed over the distant for the main route. Either of the distants can only show "off" if the stop signal is also "off".

The above list is basically all there is to British main line semaphore signalling. Of course, there are additional signals used for shunting and other local operations as described below.

4.4.6. Subsidiary Signals

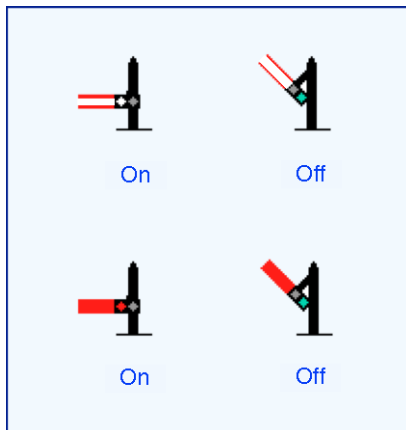

The upper signal shown in this diagram (left) was a typical shunt signal, used to allow movements into and out of a siding. It was a miniature semaphore signal with red and green lamp indications. Both upper and lower quadrant varieties were common. The signal was placed on a short post at ground level or was attached to a signal post below a normal stop signal. Subsidiary signals are those used for restricted train movements. These sorts of movements take place within a single block or in

and out of sidings. The proceed indication to the driver was a restricted movement saying "proceed at such a speed that you are able to stop short of any obstruction". There are a number of different types of secondary or subsidiary signals in use and, like the main line signals, there were lots of varieties. The most common are dealt with here.

A later version of the semaphore shunt signal was this type, with a solid red arm (left, lower), which appeared from 1925. It showed a white light, not red, when "on". It was also used for "calling on" and "warning" movements. "Calling on" refers to the advance of a train into an occupied section and was often used at stations for coupling purposes. A "warning" signal was used to advise that the overlap beyond a stop signal is occupied.

They were also used for "shunt ahead" movements - movements which have to pass the main signal for shunting purposes, normally to then 'set back' into a siding etc. The letter "S" was revealed when the arm was "off", as was the letter "C" or "W".

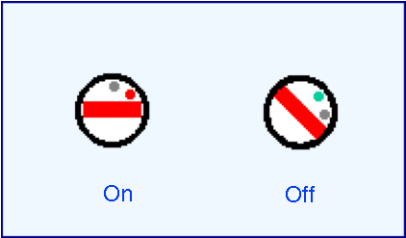

Many semaphore shunt signals were replaced by disc signals to improve visibility. The operation was the same and the arm was usually positioned on a white disc. Many of these can still be seen in the UK.

4.4.7. Colour Light Signals

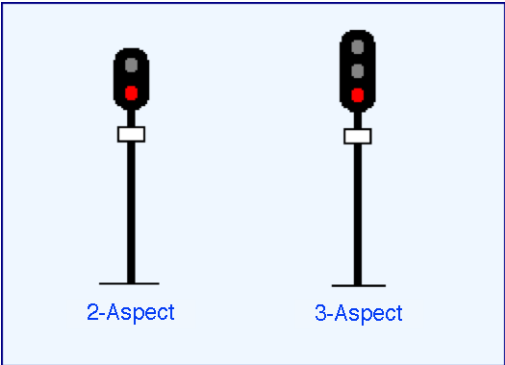

The first colour light signals appeared in the UK in the 1920s, simply as copies of semaphores. However, with the need for better track usage and higher speeds, the concept of multi-aspect signals arrived, giving the driver advance warning of the condition of several blocks ahead.

A simple 2-aspect colour light signal (left) which would act as a replacement for a semaphore stop signal. The red aspect is shown here. The other aspect is green. A 2-aspect distant signal would have yellow and green aspects. The white plate below the signal will display an identification plate using the reference letters of the controlling signal cabin and the signal number.

The 3-aspect signal (shown left) was developed to allow higher speeds and shorter block sections to accommodate more trains. The three aspects are red, yellow and green. The red indicates stop, the yellow indicates that only one block section ahead is clear and the next signal will show a stop aspect. The green indicates that at least two blocks ahead are clear. For more information see [Multi-Aspect Signalling](#) on this site.

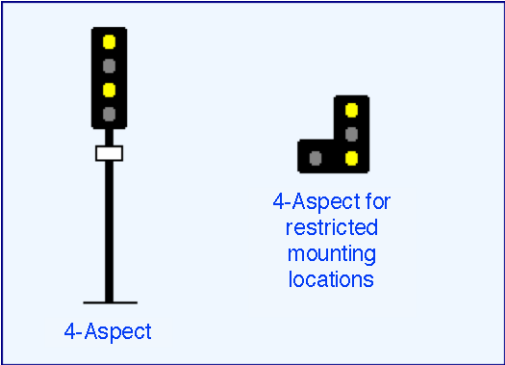

The 4-aspect signal is a further development of the multi-aspect concept. In addition to the red aspect at the bottom, this signal shows a single yellow to indicate one block ahead is clear, a double yellow (one above the other as shown here) to indicate two blocks ahead are clear and green to show at least three blocks ahead are clear.

At certain location where space is limited, a 4-aspect signal can be arranged as shown here. The red aspect is placed to one side to reduce the height of the signal.

4.4.8. 4-Aspect Operating Sequence

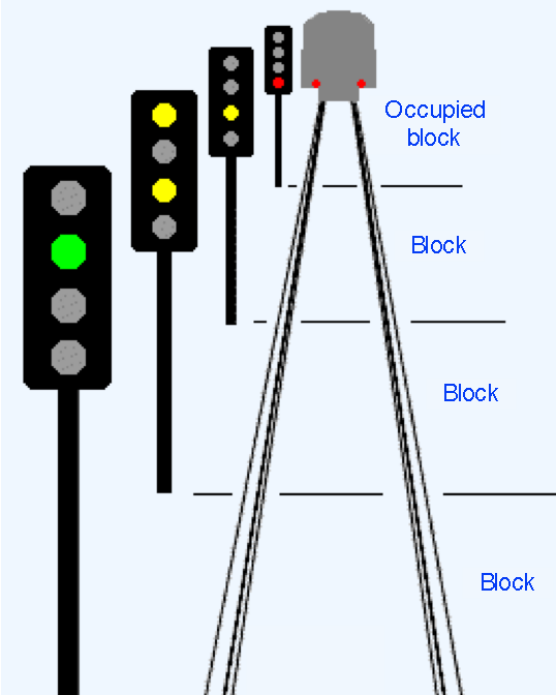

As shown in the diagram to the left, in an area where 4-aspect signalling is in use the sequence for the four signals protecting the four blocks behind a train would be red protecting the occupied clock, then single yellow, double yellow and green in the following three blocks. The view here is foreshortened for the illustration. The signals in a 4-aspect installation will be about 750 to 850 yards (686 to 777 metres) apart in an intensively used area and up to 1400 yards (1280 metres) apart in a high speed area. The signals are shown without overlaps. The sequence for 3-aspect signalling (covering only three blocks) would be the same but without the double yellow aspect and its associated block.

the double yellow aspect and its associated block.

4.4.9. Route Signalling

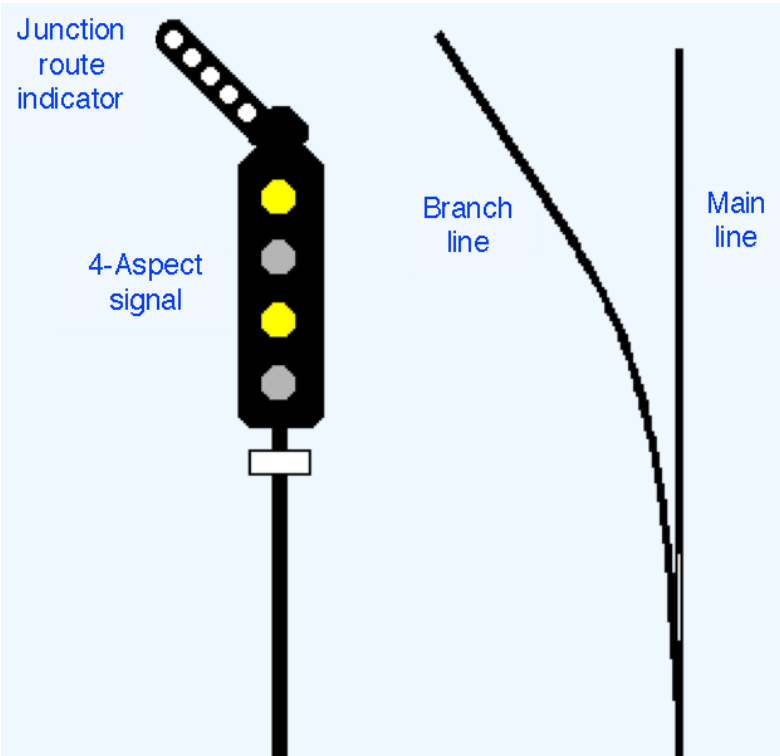

Signalling in the UK has always used the principle of "route signalling" as opposed to the "speed signalling" philosophy adopted by European and US railways. This means that drivers of a British train will be shown which route a train will take when it proceeds past a signal protecting a diverging junction, see diagram left. The speed of the train will be

a matter for the driver observing separate rules or fixed speed limit signs along the trackside. The "speed signalling" system shows the driver what speed his train must do, regardless of the route it will take. The interlocking of the signal at the junction ensures that the speed aspects shown are in accordance with the route set. The result of the UK's use of the "route signalling" philosophy is that signals display semaphore arms (as described above) or lights which indicate the route set as shown here.



Standard UK 4-aspect junction signal. The signal can show three routes: Ahead, Diverging Left and Diverging Right. The rows of five white lights are located in the angled arms above the main signal head. Note the wire screens to protect staff from contact with the electrified overhead lines.

The route is indicated by a line of five white lights which correspond to the approximate direction of the route set. The lights are known as "a feather". They will only light up when the route is set and locked and the signal is showing a proceed aspect. If the route is set for the track regarded as the main route ahead, the signal will only show a proceed aspect for this route. The "feather" will only appear to indicate a diverging route. Most examples of this signal have five white lights but three lights are used by London Underground.

It is possible to show up to seven routes with this type of signal. The route straight ahead will just get a plain green or yellow(s) while the three routes to the right or left will get the green or yellow aspects, plus a "feather". In many areas, the diversity of routes or sighting restrictions do not allow the provision of feathers. In these cases, a number or letter(s) is shown to the driver when the signal clears. This will indicate the route set.

There are still some colour light junction signals which do not have a "feather" but repeat the semaphore "splitting distant" philosophy. At a diverging route, two signal heads, side by side, are provided. One shows the main route, the other the diverging route.

The approach to some junctions is speed controlled. The signal shows a restrictive aspect until the train has approached to within a distance which has forced the driver to reduce speed. There are several variants on how this is put into practice. For a complete description, see the excellent page [Junction Signalling](#) by Clive Feather.

4.4.10. Modern Shunt Signal



This is a typical modern shunt signal, used to allow movements into and out of a siding. It has three lights with red and white indications. The signal can be seen at ground level or attached to a signal post below a normal stop signal. When mounted below a stop signal, they do not show an "on" aspect.

The ON indication shows a red and white light side by side. The OFF indication shows two white lights at 45 degrees. The newest ones have four lenses and show two red lights side by side for ON.

4.4.11. Some Photos

The following photos show some of the more modern colour light signal designs used in Britain today.

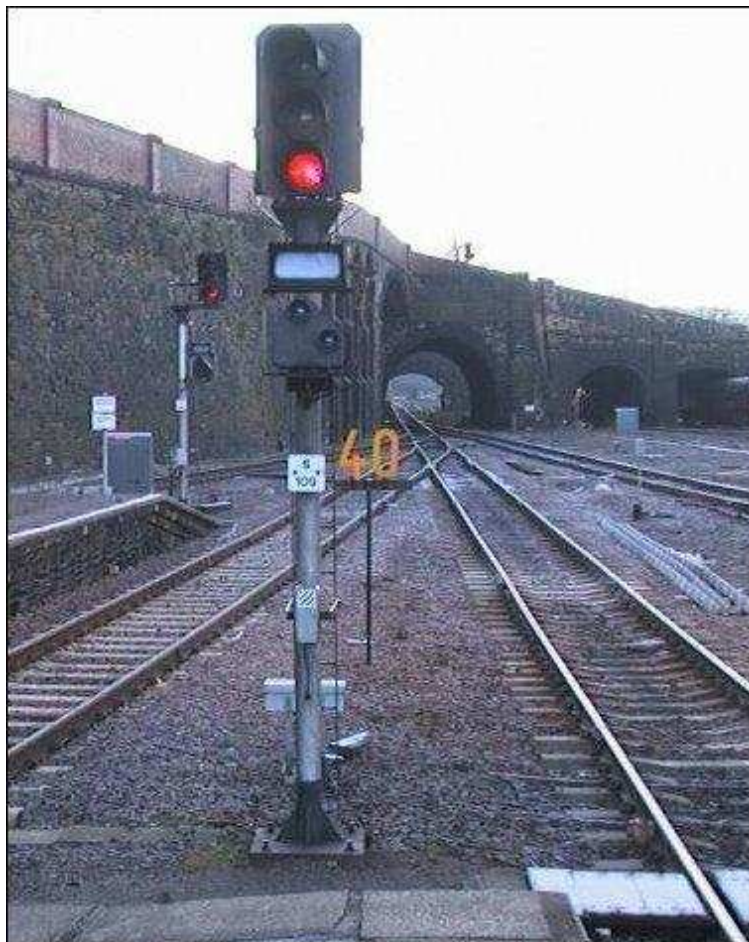

UK standard 3-Aspect Signal at Sheffield (Midland). Below the red aspect is a sign which, if the signal is showing a proceed indication, illuminates "RA" (Right Away) to tell the driver station duties are complete and he can start the train. Below this is a shunt signal, which carries no red light in this case as the red is already available on the main signal. The signal carries a white identification plate and, nearer the ground, a signal post telephone.

Standard UK 3-aspect signal. Below the red aspect is a sign which illuminates "RA" (Right Away) to inform the driver that station duties are complete. The signal post carries a shunt signal which has no red light. The stop indication is provided by the main signal. Nearer ground level is the signal post telephone. Note also the 40 mph permanent speed limit sign.



3-Aspect Signal with Theatre Type Route Indicator

Sources: "Two Centuries of Railway Signalling", Kichenside and Williams, 1998, Oxford Publishing Company, UK; "Modern Signalling Handbook", Stanley Hall, 1996, Ian Allan Ltd, Shepperton UK; "Signalling in the Age of Steam", Michael A Vanns, 1995, Ian Allan Ltd, Shepperton UK.

4.5. METRO SIGNALLING

4.5.1. Introduction

Signalling used on high density metro (or subway) routes is based on the same principles as main line signalling. The line is divided into blocks and each block is protected by a signal but, for metros, the blocks are shorter so that the number of trains using the line can be increased. They are also usually provided with some sort of automatic supervision to prevent a train passing a stop signal.

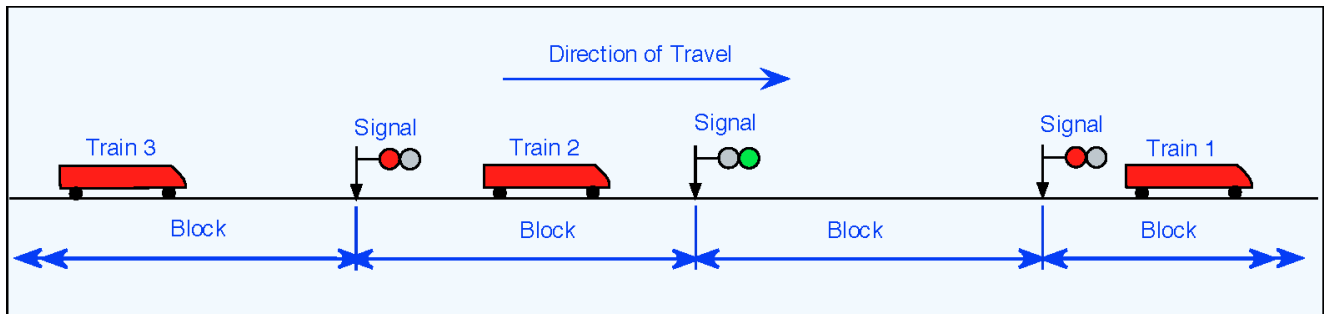

Figure 1: Diagram showing simple Metro-style two-aspect signalling.

Originally, metro signalling was based on the simple 2-aspect (red/green) system as shown above. Speeds are not high, so three-aspect signals were not necessary and yellow signals were only put in as repeaters where sighting was restricted.

Many metro routes are in tunnels and it has long been the practice of some operators to provide a form of enforcement of signal observation by installing additional equipment. This became known as automatic train protection (ATP). It can be either mechanical or electronic.

The London Underground, for example, uses both types on its lines, depending on the age of the installation. The older, mechanical version is the train stop; the later, electronic version depends on the manufacturer. The trainstop consists of a steel arm mounted alongside the track and which is linked to the signal. If the signal shows a green or proceed aspect, the trainstop is lowered and the train can pass freely. If the signal is red the trainstop is raised and, if the train attempts to pass it, the arm strikes a "tripcock" on the train, applying the brakes and preventing motoring.

Electronic ATP involves track to train transmission of signal aspects and (sometimes) their associated speed limits. On-board equipment will check the train's actual speed against the allowed speed and will slow or stop the train if any section is entered at more than the allowed speed.

4.5.2. The Overlap

If a line is equipped with a simple ATP which automatically stops a train if it passes a red signal, it will not prevent a collision with a train in front if this train is standing immediately beyond the signal.

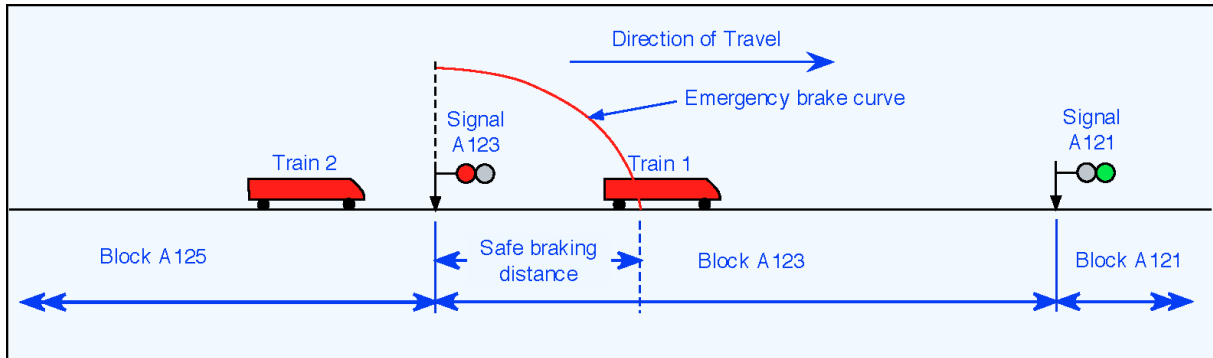

Figure 2: Diagram showing the need for a safe braking distance beyond a stop signal.

There must be room for the train to brake to a stop - see the diagram above. This is known as a "safe braking distance" and space is provided beyond each signal to accommodate it. In reality, the signal is placed in rear of the entrance to the block and the distance between it and the block is called the "overlap". Signal overlaps are calculated to allow for the safe braking distance of the trains using this route. Of course, lengths vary according to the site; gradient, maximum train speed and train brake capacity are all used in the calculation.

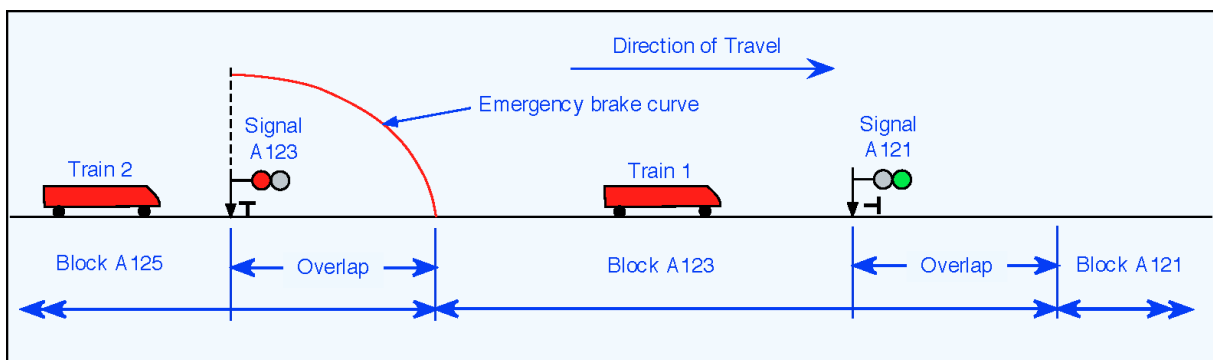

Figure 3: Diagram showing a signal provided with an overlap. The overlap in this example is calculated from the emergency braking distance required by the train at that location.

This diagram (Figure 3) shows the arrangement of signals on a metro where signals are equipped with trainstops (a form of mechanical ATP) and each signal has an overlap

whose length is calculated on the safe braking distance for that location. Signals are placed a safe braking distance in rear of the entrances to blocks. Signal A2 shows the condition of Block A2, which is occupied by Train 1. If Train 2 was to overrun Signal A2, the raised trainstop (shown here as a "T" at the base of the signal) would trip its emergency brake and bring it to a stand within the overlap of Signal A2.

Overlaps are often provided on main line railways too. In the UK, it is the practice to provide a 200 yard (185 m) overlap beyond each main line signal in a colour light installation. Back in 1972 when it was decided upon, it was, after a review of many instances where trains had overrun stop signals, considered the maximum normally required. It was a rather crude risk analysis but it was the best they could afford.

In the US, the overlap is considered so important that a whole block is provided as the overlap. It is referred to as "absolute block". This means that there is always a full, vacant block between trains. It's rather wasteful of space and it reduces capacity but it saves the need to calculate and then build in overlaps for each signal, so it's cheaper. Like a lot of things in life, you get what you pay for. We will see more about this in [Automatic Train Protection](#) below.

4.5.3. Track-Circuited Overlaps

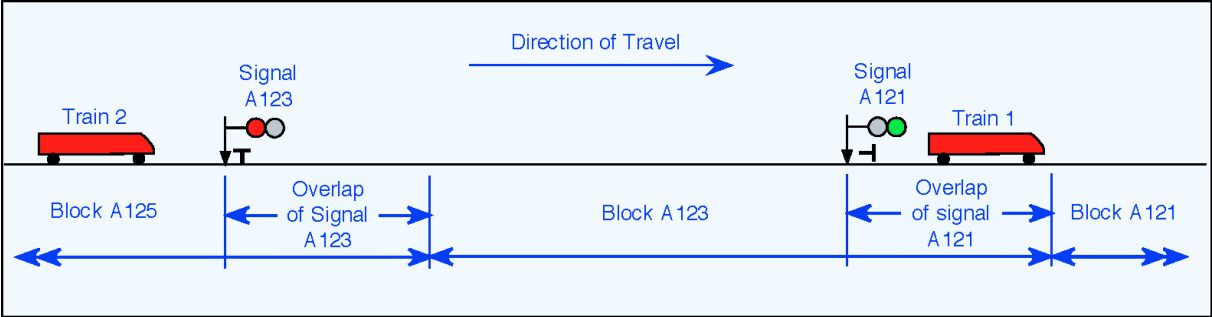

Figure 4: Diagram showing a train standing in the signal overlap.

Nothing in the railway business is as simple as it seems and so it is with overlaps. A line which uses overlaps and has close [headways](#) could have a situation as shown above where the train in the overlap of Signal A121 has a green signal showing behind it. Although it is protected by Signal A123 showing red, the driver of Train 2 may see the green signal A121 behind Train 1 and could "[read through](#)" or be confused under the "[stop and proceed](#)" rule.

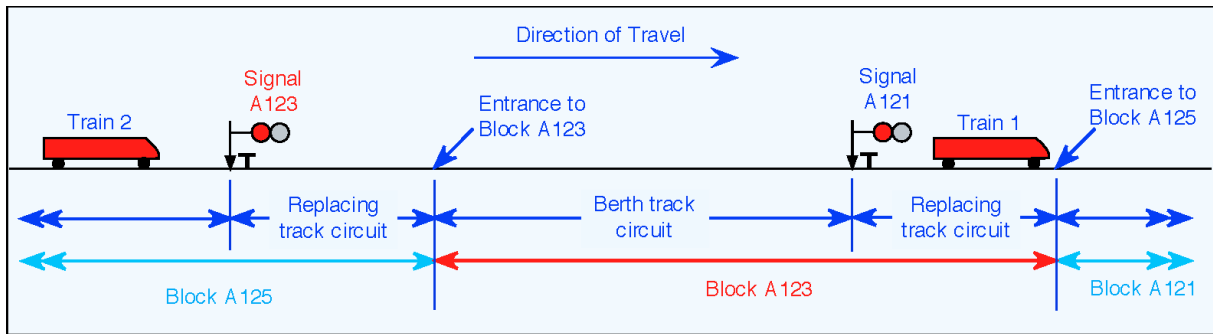

Figure 5: Diagram of the track circuited overlap, sometimes known as a "replacing track circuit".

So, where there is a possibility of a green signal being visible behind a train, overlaps are track circuited as shown in Fig. 5. Although there is no train occupying the block protected by Signal A121, the signal is showing a red aspect because the train is occupying the overlap track circuit or "replacing" track circuit, as it is sometimes called. This will give rise to two red signals showing behind a train whilst the train is in the overlap. The block now has two track circuits, the "Berth" track and the "replacing" track.

4.5.4. Absolute Block

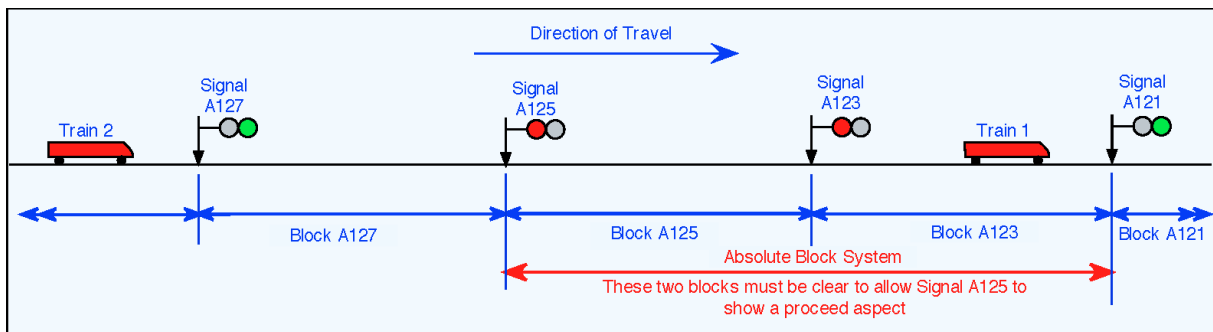
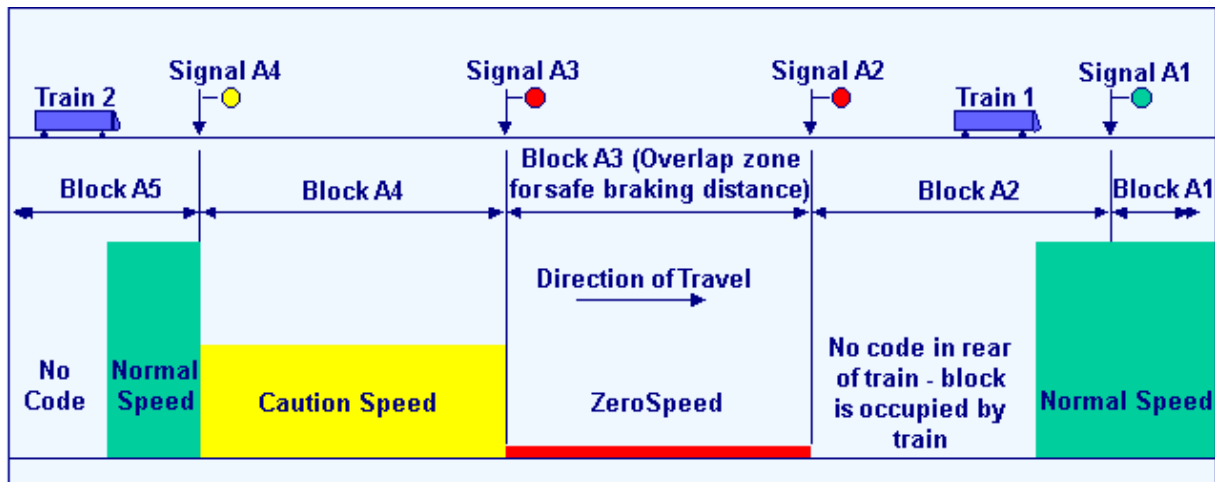

Figure 6: Schematic showing the principle of the Absolute Block system. Signal A127 is clear because two blocks in advance of it are clear. A125 shows a danger aspect because one of the blocks ahead of it is occupied by a train.

Many railways use an "Absolute Block" system, where a vacant block is always maintained behind a train in order to ensure there is enough room for the following train to be stopped if it passes the first stop (red) signal. In Figure 6, in order for Signal A125 to show a proceed aspect (green), the two blocks ahead of it must be clear, with Train 1 completely inside the block protected by Signal A121.

4.5.5. Automatic Train Protection



To adapt metro signalling to modern, electronic ATP, the overlaps are incorporated into the block system. This is done by counting the block behind an occupied block as the overlap. Thus, in a full, fixed block ATP system, there will be two red signals and an unoccupied, or overlap block between trains to provide the full safe braking distance, as shown here. As an aside, remember that, although I have shown signals here, many ATP equipped systems do not have visible lineside signals because the signal indications are transmitted directly to the driver's cab console (cab signalling).

On a line equipped with ATP as shown above, each block carries an electronic speed code on top of its track circuit. If the train tries to enter a zero speed block or an occupied block, or if it enters a section at a speed higher than that authorised by the code, the on-board electronics will cause an emergency brake application. This is the system used by London Underground for the Victoria Line from 1968 - the first fully automatic, passenger carrying railway ([more information here](#)). It was a simple system with only three speed codes - normal, caution and stop. Many systems built since are based on it but improvements have been added.

4.5.6. ATP Speed Codes

A train on a line with a modern version of ATP needs two pieces of information about the state of the line ahead - what speed can it do in this block and what speed must it be doing by the time it enters the next block. This speed data is picked up by antennae on the train. The data is coded by the electronic equipment controlling the track circuitry and transmitted from the rails. The code data consists of two parts, the authorised speed code for this block and the target speed code for the next block. The diagram below shows how this works.

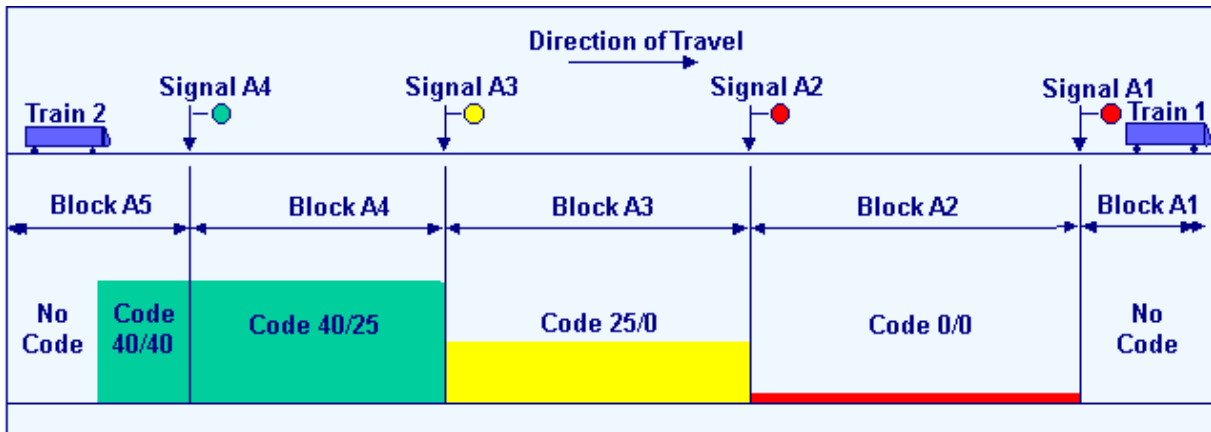

In this example (left), a train in Block A5 approaching Signal A4 will receive a 40 over 40 code (40/40) to indicate a permitted speed of 40 km/h in this block and a target speed of 40 km/h for the next. This is the normal speed data. However, when it enters Block A4, the code will change to 40/25 because the target speed must be 25 km/h when the train enters the next Block A3. When the train enters Block A3, the code changes again to 25/0 because the next block (A2) is the overlap block and is forbidden territory, so the speed must be zero by the time train reaches the end of Block A3. If the train attempts to enter Block A2, the on-board equipment will detect the zero speed code (0/0) and will cause an emergency brake application. As mentioned above, Block A2 is acting as the overlap or safe braking distance behind the train occupying Block A1.

4.5.7. Operating with ATP

Trains operating over a line equipped with ATP can be manually or automatically driven. To allow manual driving, the ATP codes are displayed to the driver on a panel in his cab. In our example below, he would begin braking somewhere around the brake initiation point because he would see the 40/25 code on his display and would know, from his knowledge of the line, where he will have to stop. If signals are not provided, the signal positions will normally be indicated by trackside block marker boards to show drivers the entrances to blocks.

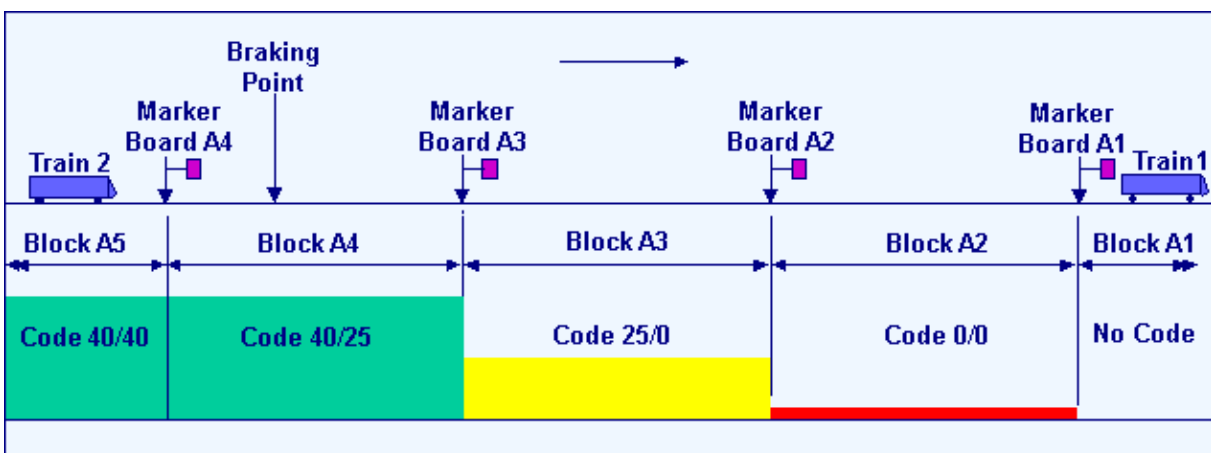

If the train is installed with automatic driving (ATO - Automatic Train Operation), brake initiation for the reduced target speed can be by either a track mounted electronic "patch" or "beacon" placed at the brake initiation point or, more simply, by the change in the coded track circuit. Both systems are used by different manufacturers but, in both, the train passes through a series of "speed steps" to the signalled stop.

When the first train clears Block A1, the codes in Blocks A2, A3 and A4 will change to the next speed up and any train passing through them will receive immediately a new permitted speed and a new target speed for the next block. This allows an instant response to changing conditions and helps to keep trains moving.

4.5.8. Distance-to-Go

The next stage of ATP development was an attempt to eliminate the space lost by the empty overlap block behind each train. If this could be eliminated, line capacity could be increased by up to 20%, depending on block lengths and line speed. In this diagram, the train in Block A1 causes a series of speed reduction steps behind it so that, if a following train enters Block A6, it will get a reduced target speed. As it continues towards the zero speed block A2, it gets a further target speed reduction at each new block until it stops at the end of Block A3. It will stop before entering Block A2, the overlap block. The braking curve is shown here in brown as the "standard" braking curve.

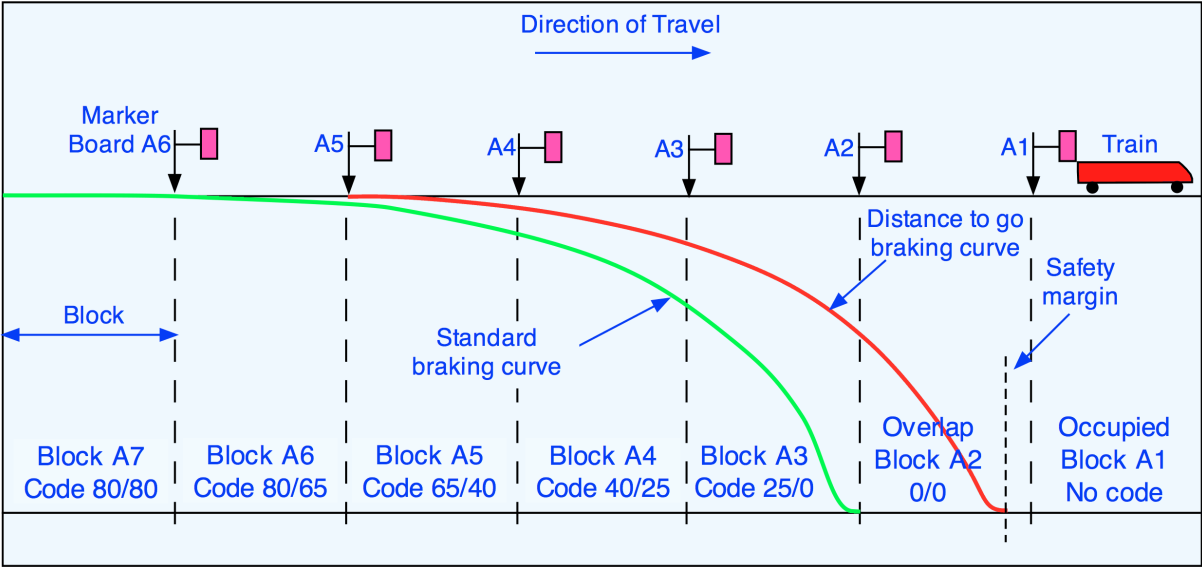

To remove the overlap section, it is simply a question of moving the braking curve forward by one block. The train will now be able to proceed a block closer (A5 instead of A6) to the occupied block, before it gets a target speed reduction. However, to get this close to the occupied block requires accurate and constant checking of the braking by the train, so an on-board computer calculates the braking curve required, based on the distance to go to the stopping point and using a line map contained in the computer's

memory. The new curve is shown in blue in the diagram. A safety margin of 25 metres or so is allowed for error so that the train will always stop before it reaches the critical boundary between Blocks A2 and A1. Note that the braking curve should reduce (or "flare out") at the final stopping point in order to give the passengers a comfortable stop.

4.5.9. Speed Monitoring

Both the older, speed step method of electronic ATP and "distance-to-go" require the train speed to be monitored. In Fig 8 above, we can see the standard braking curve of the speed step system always remains inside the profile of the speed steps. The train's ATP equipment only monitors the train's speed against the permitted speed limit within that block. If the train goes above that speed, an emergency brake application will be invoked. The standard braking curve made by the train is not monitored.

For the distance-to-go system, the development of modern electronics has allowed the brake curve to be monitored continuously so that the speed steps become unnecessary. When it enters the first block with a speed restriction in the code, the train is also told how far ahead the stopping point is. The on-board computer knows where the train is now, using the line "map" embedded in its memory, and it calculates the required braking curve accordingly. As the train brakes, the computer checks the progress down the curve to check the train never goes outside it. To ensure that the wheel revolutions used to count the train's progression along the line have not drifted due to wear, skidding or sliding, the on-board map of the line is updated regularly during the trip by fixed, track-mounted beacons laid between the rails.

4.5.10. Operation with Distance-to-Go

Distance-to-go ATP has a number of advantages over the speed step system. As we have seen, it can increase line capacity but also it can reduce the number of track circuits required, since you don't need frequent changes of steps to keep adjusting the braking distance. The blocks are now just the spaces to be occupied by trains and are not used as overlaps as well. Distance-to-go can be used for manual driving or automatic operation.

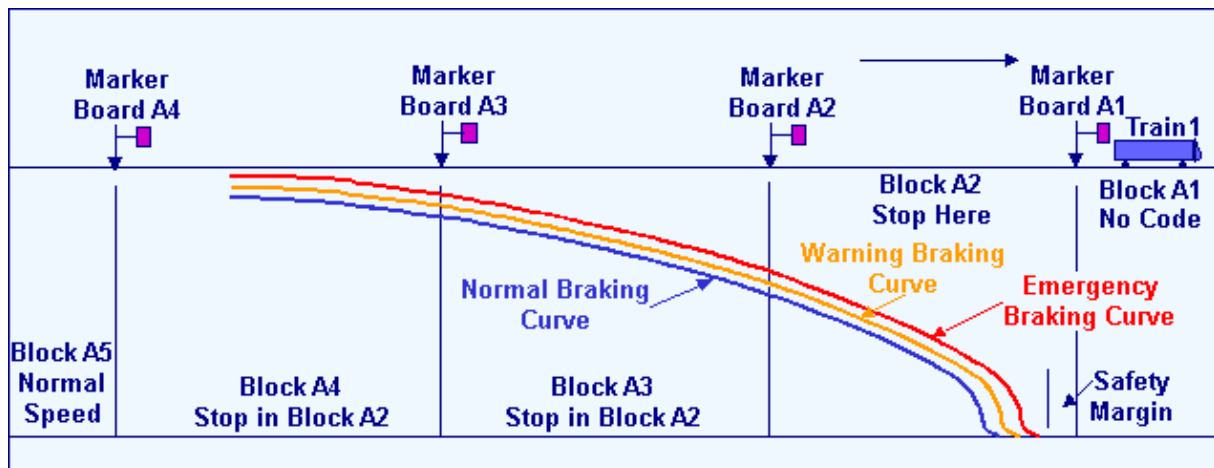

Systems vary but often, several curves are provided for the train braking profile. This example shows three: One is the normal curve within which the train should brake, the second is a warning curve, which provides a warning to the driver (an audio-visual alarm or a service brake application depending on the system) and the third is the emergency curve which will force an emergency brake if the driver does not reduce speed to within the normal curve.

Why doesn't everyone use distance-to-go? Partly because the systems used by many operators were installed before distance-to-go became available. Also, some operators require the safety margin, particularly in the US where they insist on an extra margin, known as the "lurch" factor, to allow for a train which decides to "motor" instead of "brake", as once happened in San Francisco.

Notes:

Headway: The time interval at a fixed point between the passing of one train and the passing of the next

Read Through: Where a green signal seen beyond a red signal causes the driver to proceed in error.

Stop and Proceed: Used under special conditions to allow a train to pass a red signal at severely restricted speed.

4.6. ATP BEACONS AND MOVING BLOCK

4.6.1. Introduction

This page has further information on Automatic Train Protection (ATP) with descriptions of beacons and moving block systems.

4.6.2. ATP Code Transmission

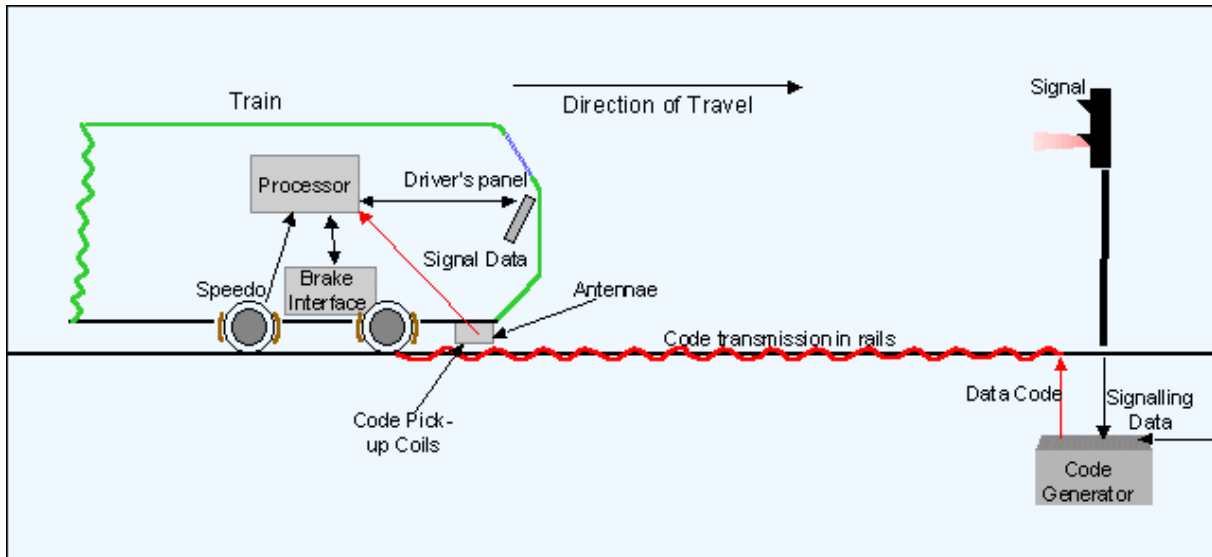

We have seen in the [previous articles](#) that the ATP signalling codes contained in the track circuits are transmitted to the train. They are detected by pick-up antennae (usually two) mounted on the leading end of the train under the driving cab. This data is passed to an on-board decoding and safety processor. The permitted speed is checked against the actual speed and, if the permitted speed is exceeded, a brake application is initiated. In the more modern systems, distance-to-go data will be transmitted to the train as well. The data is also sent to a display in the cab which allows the driver of a manually driven train to respond and drive the train within the permitted speed range.

At the trackside, the signal aspects of the sections ahead are monitored and passed to the code generator for each block. The code generator sends the appropriate codes to the track circuit. The code is detected by the antennae on the train and passed to the on-board computer. As we have seen, the computer will check the actual speed of the train with the speed required by the code and will cause a brake application if the train speed is too high.

4.6.3. Beacon Transmission

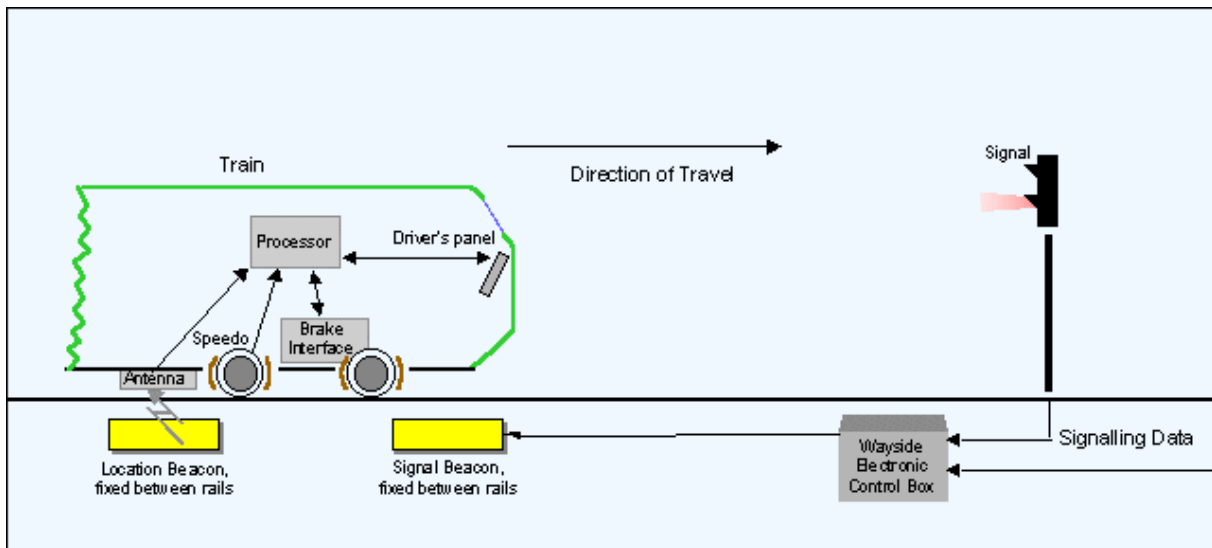

In the examples so far, the ATP data from the track to the train is transmitted by using coded track circuits passing through the running rails. It is known as the "continuous" transmission system because data is passing to the train all the time. However, it does have its limitations. There are transmission losses over longer blocks and this reduces the effective length of a track circuit to about 350 metres. The equipment is also expensive and vulnerable to bad weather, electronic interference, damage, vandalism and theft. To overcome some of these drawbacks, a solution using intermittent transmission of data has been introduced. It uses electronic beacons placed at intervals along the track.

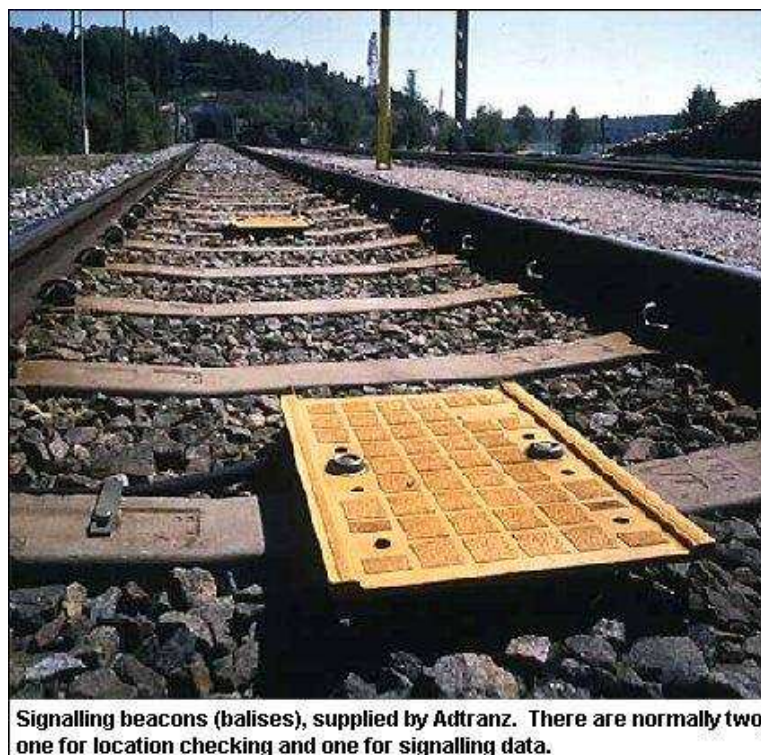

In the best known system, originally developed by Ericsson in Sweden and formerly marketed by Adtranz (now Bombardier), there are usually two beacons, a location beacon to tell the train where it is and a signalling beacon to give the status of the sections ahead. The beacons are sometimes referred to as "balises" after the French. Data processing and the other ATP functions are similar to the continuous transmission system.

4.6.4. Operation With Beacons

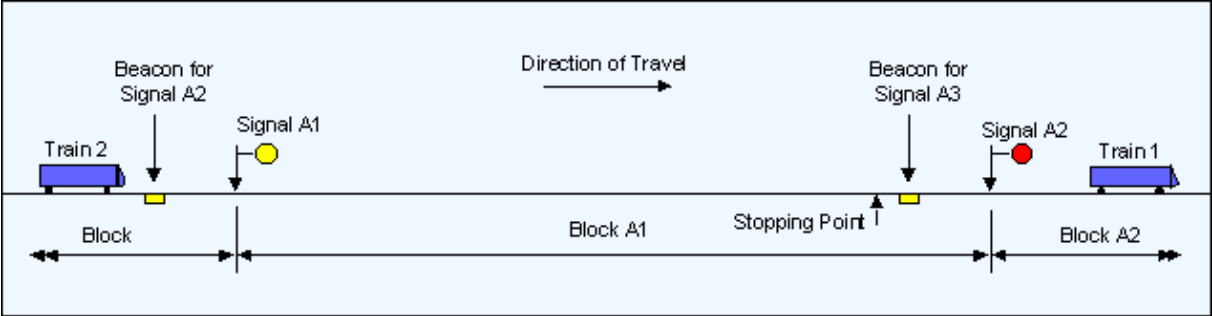

The beacon system operates as shown in the simplified diagrams below. In the diagram (left), the beacon for red Signal A2 is located before Signal A1 to give the approaching train (2) room to stop. Train 2 will get its stopping command here so that it stops before it reaches the beacon for signal A3.

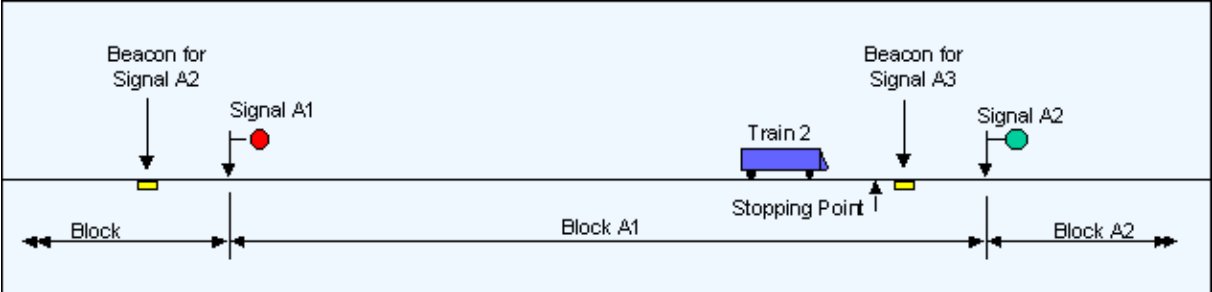

In the diagram on the left, the train has stopped in front of Signal A2 and will wait until Train 2 clears Block A2 and the signal changes to green. In reality, it will not move even then, since it requires the driver to reset the system to allow the train to be restarted. For this reason, this type of ATP is normally used on manually driven systems.

4.6.5. Intermittent Updates

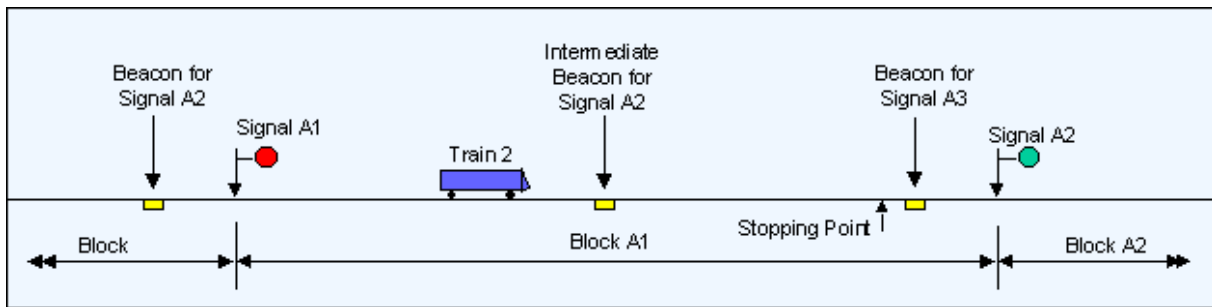

A disadvantage of the beacon system is that once a train has received a message indicating a reduced speed or stop, it will retain that message until it has passed another beacon or has stopped. This means that if the block ahead is cleared before Train 2 reaches its stopping point and the signal changes to green, the train will still have the stop message and will stop, even though it doesn't have to. Why, might you ask, can't the driver cancel the stop message like he does when the train has stopped and the signal changes to green? If he could cancel the stop message while the train was moving, the system would be no better than the AWS with its cancel button. ATP is "vital" or "fail-safe" and must not allow human intervention to reduce its effectiveness.

To avoid the situation of an unnecessary stop, an intermediate beacon is provided. This updates the train as it approaches the stopping point and will revoke the stop command if the signal has cleared. More than one intermediate beacon can be provided if necessary.

4.6.6. Moving Block - The Theory

As signalling technology has developed, there have been many refinements to the block system but, in recent years, the emphasis has been on attempts to get rid of fixed blocks altogether. Getting rid of fixed blocks has the advantage that you can vary the distances between trains according to their actual speed and according their speeds in relation to each other. It's rather like applying the freeway rules for speed separation - you don't need to be a full speed braking distance from the car in front because he won't stop dead. If you are moving at the same speed as he is, you could, in theory, travel immediately behind him and, when he brakes, you do. If you allow a few metres for reaction time to his brake lights and variations in braking performance, it works well. Although it only needs a few spectacular collisions on the freeways to disprove the theory for road traffic, in the more regulated world of the railway, although it could not be applied without a full safe braking distance between trains, it has possibilities.

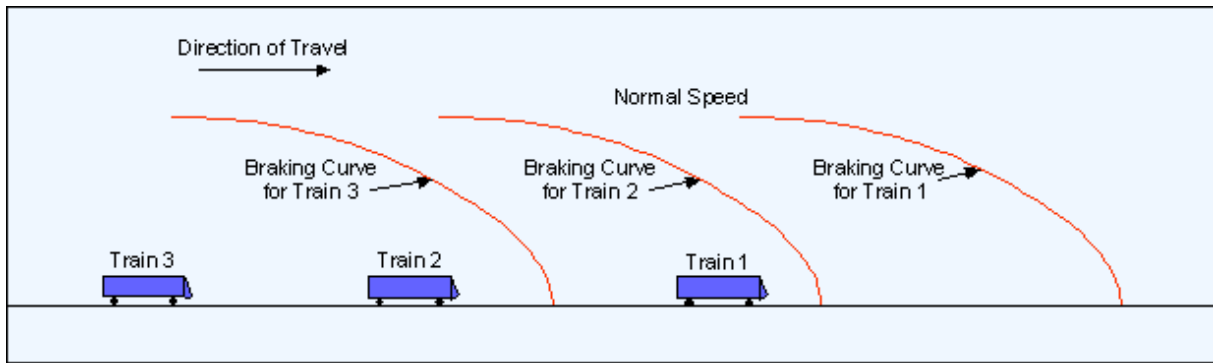

In the diagram (left), as long as each train is travelling at the same speed as the one in front and they all have the same braking capabilities, they can, in theory, run as close together as a few metres. Just allow some room for reaction time and small errors and trains could run as close together as 50 metres at 50 km/h. Well, that's OK in theory but, in practice, it's a different matter and, as yet, no one has taken moving block design this far and they are unlikely to do so in the near future. The recent ICE high speed accident in Germany where a train derailed, struck a bridge and stopped very quickly, effectively negates the safety value of the theoretical moving block system described above. This means that it is essential to maintain a safe braking distance between trains at all times.

What is worth doing, is making the the block locations and lengths consistent with train location and speed, i.e. making them movable rather than fixed. This flexibility requires radio transmission, sometimes called Communications Based Train Control (CBTC) or Transmission Based Signalling (TBS) rather than track circuit transmission, to detect the location, speed and direction of trains and to tell trains their permitted operating speed.

4.6.7. Moving Block and Radio Transmission

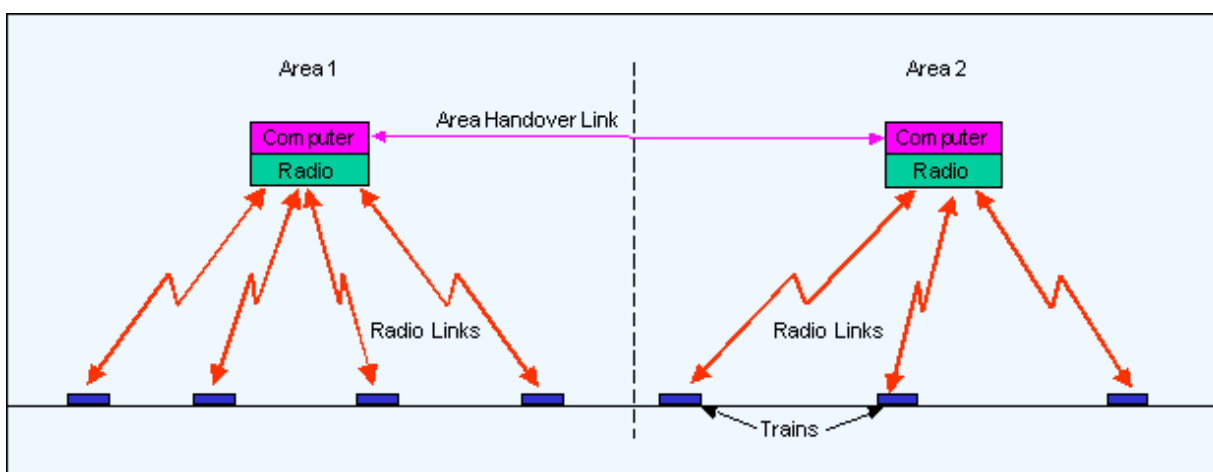

On a moving block equipped railway, the line is usually divided into areas or regions, each area under the control of a computer and each with its own radio transmission system. Each train transmits its identity, location, direction and speed to the area

computer which makes the necessary calculations for safe train separation and transmits this to the following train as shown here.

The radio link between each train and the area computer is continuous so the computer knows the location of all the trains in its area all the time. It transmits to each train the location of the train in front and gives it a braking curve to enable it to stop before it reaches that train. In effect, it is a dynamic distance-to-go system. This is Communications Based Train Control (CBTC).

One fixed block feature has been retained - the requirement for a full speed braking distance between trains. This ensures that, if the radio link is lost, the latest data retained on board the following train will cause it to stop before it reaches the preceding train. The freeway style vision of two trains moving at 50 km/h with 50 metres between them is a step too far into virtual reality for most operators.

4.6.8. Moving Block - Location Updates

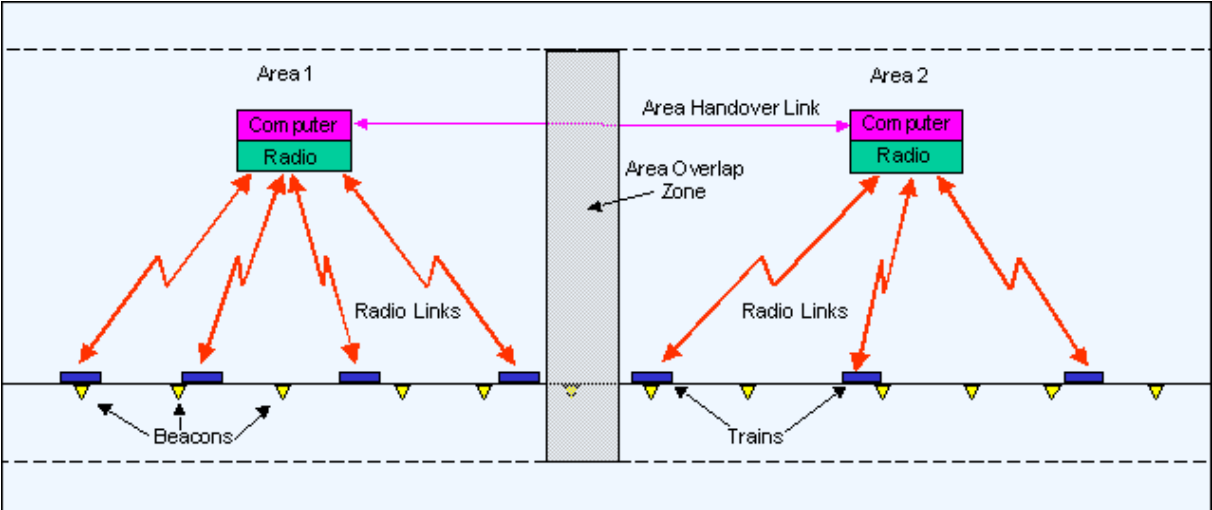

As we have seen, trains in a moving block system report their position continuously to the area computer by means of the train to wayside radio. Each train also confirms its own position on the ground from beacons, located at intervals along the track, which recalibrate the train's position compared with the on-board, computerised line map.

Transferring a train from one area to another is also carried out by using the radio links and, additionally by a link between the two adjacent area computers. The areas overlap each other so, when a train first reaches the boundary of a new area, the computer of the first area contacts the computer of the second area and alerts it to listen for the new train's signal. It also tells the train to change its radio codes to match the new area. When the new area picks up the ID of the train it acknowledges the handover from the first area and the transfer is complete.

Another version of the moving block system has the location computers on the trains. Each train knows where it is in relation to all the other trains and sets its safe speeds using this data. It has the advantage that there is less wayside equipment required than with the off-train system but the amount of transmissions is much greater.

4.6.9. An Early Moving Block System

One system which claims the distinction of being the first moving block system is that marketed under the name Seltrac by Alcatel. It is used in Canada and on the Docklands Light Railway in London. It has the ingredients of moving transmission of data, but the transmission medium is the track-mounted induction loops which are laid between the rails and which cross every 25 metres to allow trains to verify their position. Data is passed between the vehicle on-board computer (VOBC) and the vehicle control centre (VCC) through the loops. The VCC controls the speed of Train 2 by checking the position of Train 1 and calculating its safe braking curve.

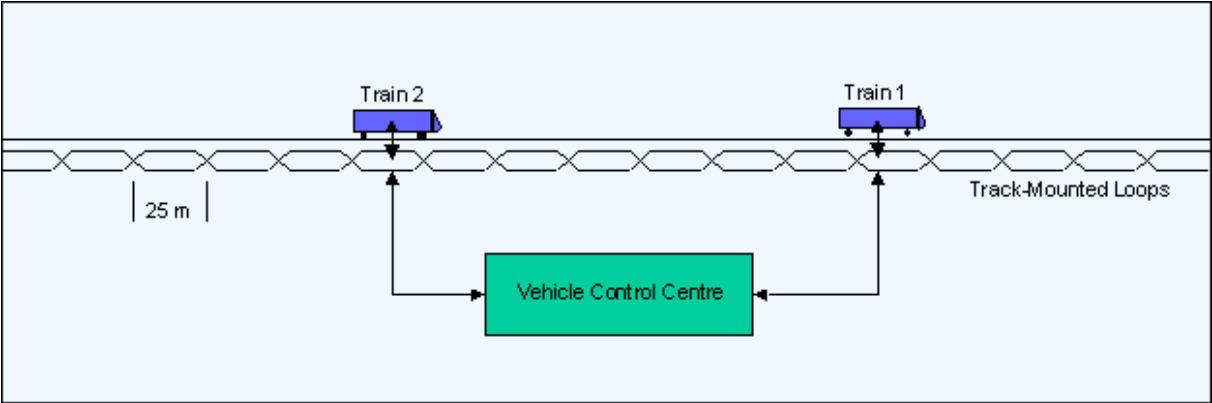

The Seltrac system requires no driver, as it is fully automatic. In case of a system failure where a train has to be manually driven, it has axle counters¹ to verify the position of a train not under the control of the loops. Perhaps its biggest drawback is the need for continuous cables to be laid within the tracks, expensive to install and open to damage during track maintenance.

The principle difference between this system and the more modern ones being marketed today is that Seltrac uses electro-magnetic transmission of data requiring track cables, whereas radio based systems only require aerials. Seltrac is upgrading their design to use radio based transmission.

4.6.10. Moving Block - Why Do We Need It?

Railway signalling has traditionally required a large amount of expensive hardware to be distributed all along a route which is exposed to variable climatic conditions, wear, vandalism, theft and heavy usage. Because of the widely spaced distribution, maintenance is expensive and often restricted to times when trains are not running.

Failures are difficult to locate and difficult to reach. On metros, access is further restricted where there are tunnels and elevated sections. For these reasons, railway operators have been trying to reduce the wayside signalling equipment and so reduce maintenance costs. Reduced wayside equipment can also lead to reduced installation costs. Moving block requires less wayside equipment than fixed block systems.

There is another goal much sought after by operators - greater capacity. A norm for most metro lines is 30 trains per hour (tph) or a two-minute headway. It is debatable whether much improvement on this is possible for a high capacity system, since the major losses of line capacity occur because of station stops and terminal operations. Heavily used metro lines, like those in Hong Kong, trying for a greater capacity than 30 trains per hour, will struggle to keep dwell times below 40-50 seconds at peak times. This will push the headway to two minutes or longer, regardless of the signalling system used. Similar problems exist at terminals where crossover clearance times are critical. Moving block signalling cannot provide much improvement. Shorter headways can, however, be achieved on systems where trains are shorter, speeds lower and the passenger levels smaller. In some places a 95 second headway can be achieved on systems like Docklands and certain sections of the Paris Metro.

Also, for underground lines, modern ventilation and smoke control systems will require train separation of 2-300 metres to allow air circulation at critical times. If moving block signalling allows 50 metre separation, some very expensive additional ventilation arrangements might be necessary. This may reduce the benefits of moving block.

The real prize which could be won by an operator using moving block is reduced wayside equipment and reduced maintenance costs. Better reliability and quicker fault location is also possible with moving block technology. If radio based transmission is included, an all-round improvement can be achieved.

One other factor to be noted is that many operators specifying moving block technology also ask for fixed block track circuits to serve as a back up and for broken rail detection. Track circuits are also still required for junctions. One might ask, if such equipment is to be installed anyway, why add the expense of radio-based transmission?

Note:

1. Axle counters are sometimes used as a way of verifying that a train has completely passed through a block instead of a track circuit. The number of axles on the train are counted as the train enters the block and counted again as it exits.

4.7. AUTOMATIC TRAIN OPERATION

4.7.1. ATO

So far, we have only seen how ATP systems work on metros. ATP is the safety system which ensures that trains remain a safe distance apart and have sufficient warning to allow them to stop without colliding with another train. ATO (Automatic Train Operation) is the non-safety part of train operation related to station stops and starts.

The basic requirement of ATO is to tell the train approaching a station where to stop so that the complete train is in the platform. This is assuming that the ATP has confirmed that the line is clear. The sequence operates as shown below.

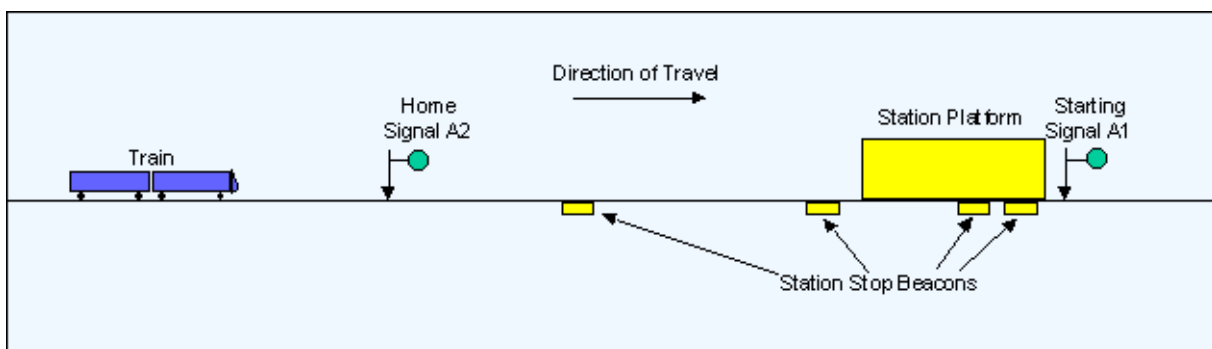

The train approaches the station under clear signals so it can do a normal run in. When it reaches the first beacon - originally a looped cable, now usually a fixed transponder - a station brake command is received by the train. The on board computer calculates the braking curve to enable it to stop at the correct point and, as the train runs in towards the platform, the curve is updated a number of times (it varies from system to system) to ensure accuracy.

London's Victoria Line, now 35 years old, has up to 13 "patches" checking the train speed as it brakes into a station. This high number of checks is needed because the on-board braking control gives only three fixed rates of deceleration. Even then, stopping accuracy is ± 2 metres. A detailed description of the [Victoria Line's ATO system is here](#). Modern systems require less wayside checking because of the dynamic and more accurate on-board braking curve calculations. Now, modern installations can achieve ± 0.15 metres stopping accuracy - 14 times better.

4.7.2. Metro Station Stops

ATO works well when the line is clear and station run-ins and run-outs are unimpeded by the train ahead. However, ATO has to be capable of adapting to congested conditions, so it has to be combined with ATP at stations when trains are closely following each other. Metro operation at stations has always been a particular challenge and, long before ATO

appeared in the late 1960s, systems were developed to minimise the impact when a train delayed too long at a station.

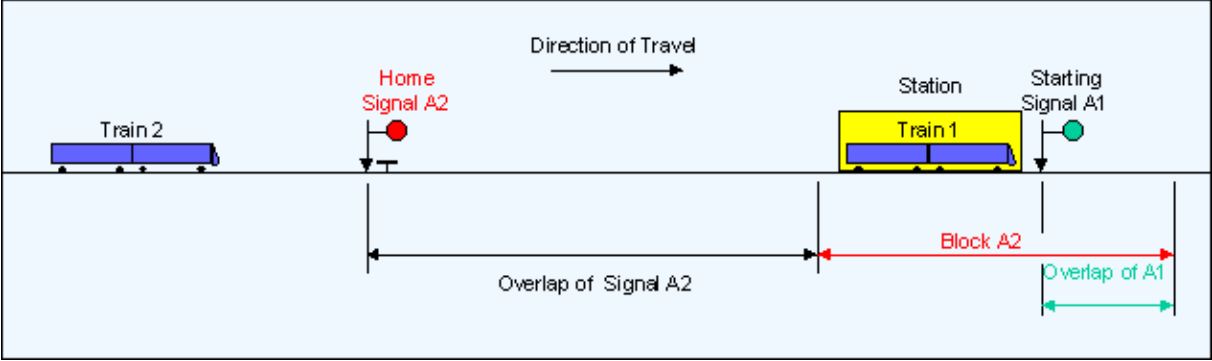

To provide a frequent train service on a metro, dwell times at stations must be kept to a minimum. In spite of the best endeavours of staff, trains sometimes overstay their time at stations, so signalling was developed to reduce the impact on following trains. To see how this works, we begin with an example (left) of a conventionally signalled station with a starting Signal A1 (green) and a home Signal A2 (red) protecting a train (Train 1) standing in the station. We can assume mechanical ATP (trainstops) is provided so the overlap of Signal A2 is a full speed braking distance in advance of the platform.

As Train 2 approaches, it slows when the driver sees the home Signal A2 at danger. Even if Train 1 then starts and begins to leave the station, Signal A2 will remain at danger until Train 1 has cleared the overlap of Signal A1. Train 2 will have to stop at A2 but will then restart almost immediately when Signal A2 clears. This causes a delay to Train 2 and it requires more energy to restart the train. A way was found to allow the second train to keep moving. It is called multi-home signalling.

4.7.3. Multi Home Signalling - Approach

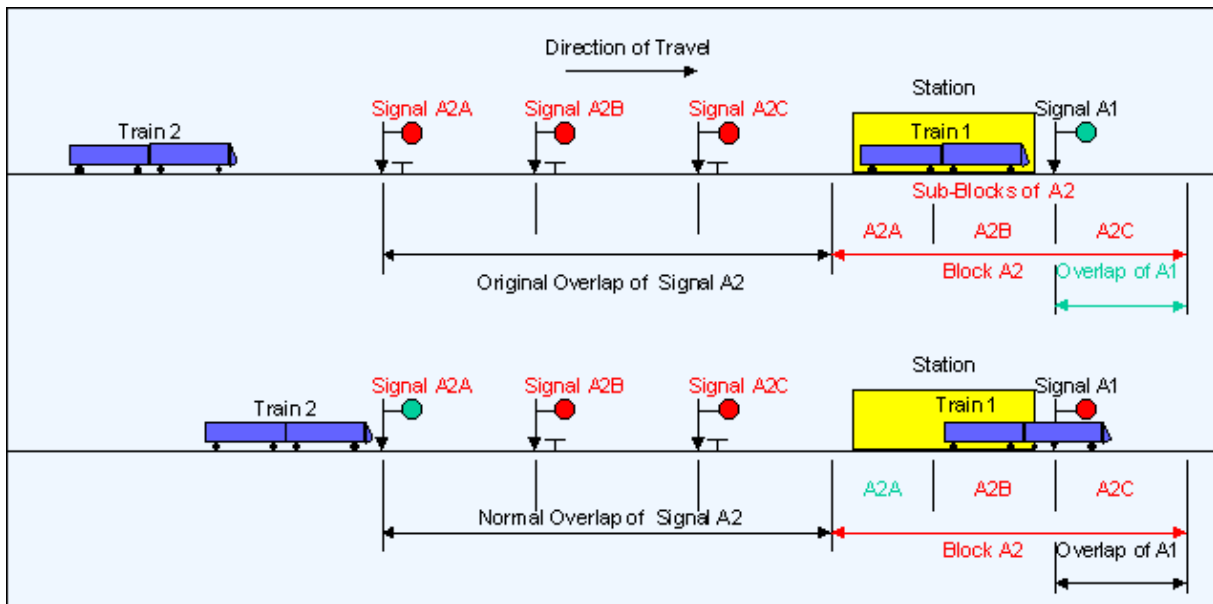

Where multi-home signalling is installed at a station, it involves the provision of more but shorter blocks, each with its own signal. The original home signal in our example has become Signal A2A and, while Train 1 is in the platform, it will remain at danger. However, Block A2 is broken up into three smaller sub-blocks, A2A, A2B and A2C, each with its own signal. They will also be at danger while Train 1 is in the platform. Train 2 is approaching and beginning to brake so as to stop at Signal A2A.

When Train 1 begins to leave the station, it will clear sub-block A2A first and signal A2A will then show green. Train 2 will have reduced speed somewhat but can now begin its run in towards the platform.

4.7.4. Multi Home Signalling - Run In

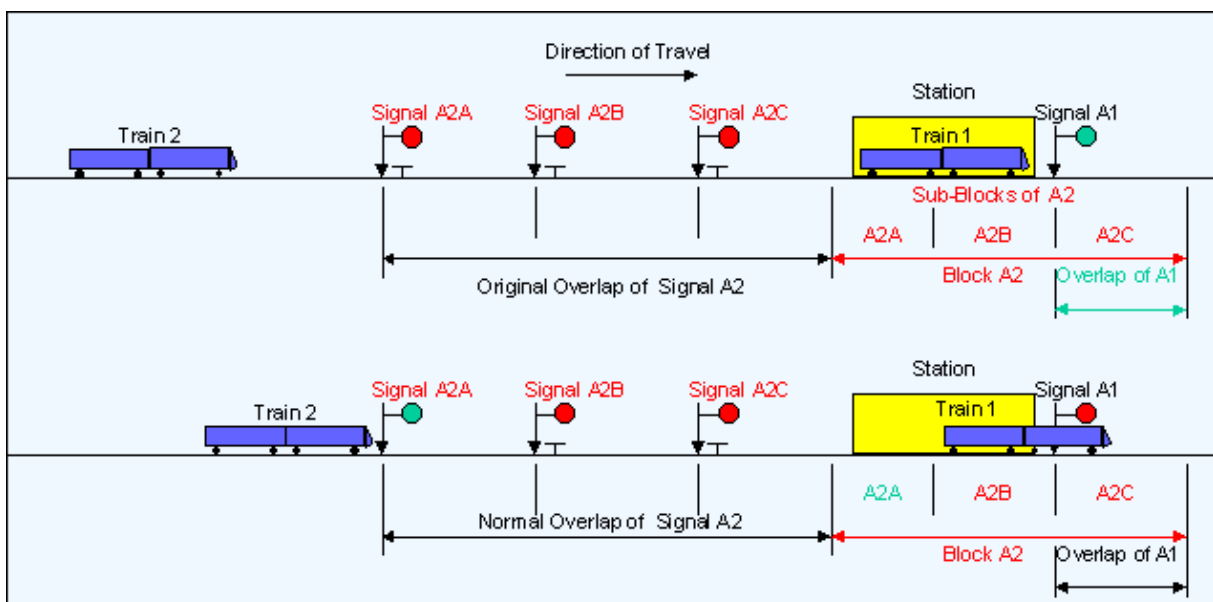

At this next stage in the sequence, we can see that Train 1 has now cleared two sub-blocks, A2A and A2B, so two of the multi-home signals are now clear. Note that the starting signal is now red as the train has entered the next block A1. Train 2 is running towards the station at a reduced speed but it has not had to stop.

When Train 1 clears the overlap of signal A1, the whole of block A2 is clear and signal A2C clears to allow Train 2 an unobstructed run into the platform.

4.7.5. ATO/ATP Multi Home Signalling

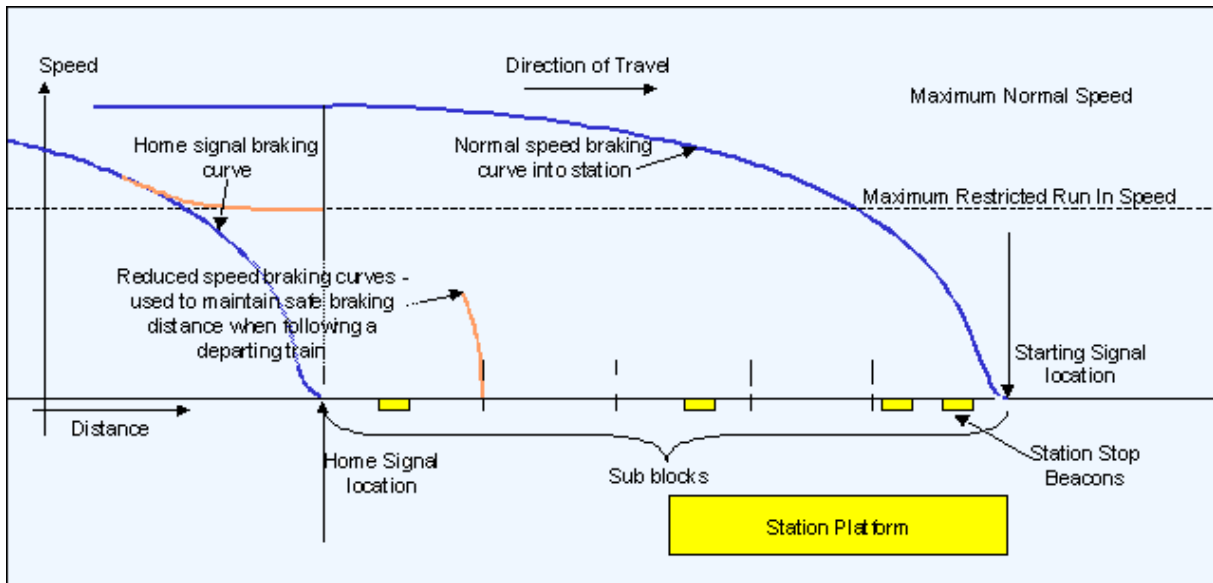

Fixed block metro systems use multi-home signalling with ATO and ATP. A series of sub-blocks are provided in the platform area. These impose reduced speed braking curves on the incoming train and allow it to run towards the platform as the preceding train departs, whilst keeping a safe braking distance between them. Each curve represents a sub-block. Enforcement is carried out by the ATP system monitoring the train speed. The station stop beacons still give the train the data for the braking curve for the station stop but the train will recalculate the curve to compensate for the lower speed imposed by the ATP system.

4.7.6. ATO Docking and Starting

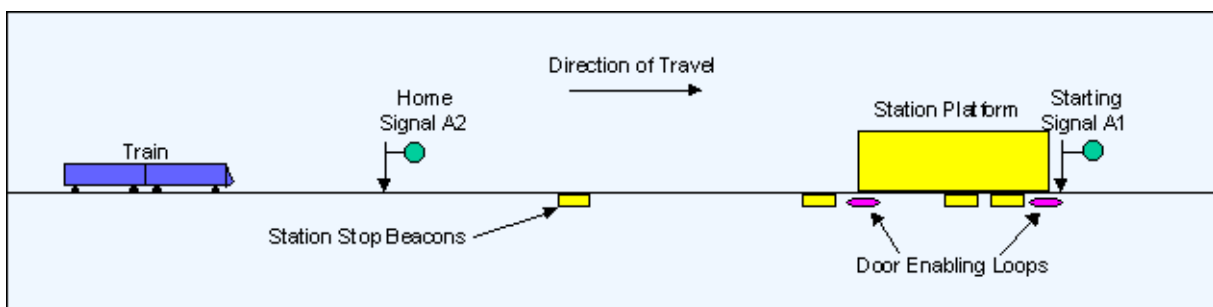

In addition to providing an automatic station stop, ATO will allow "docking" for door operation and restarting from a station. If a "driver", more often called a "train operator" nowadays, is provided, he may be given the job of opening and closing the train doors at a station and restarting the train when all doors are proved closed. Some systems are designed to prevent doors being opened until the train is "docked" in the right place. Some systems even take door operation away from the operator and give it to the ATO system so additional equipment is provided as shown left.

When the train has stopped, it verifies that its brakes are applied and checks that it has stopped within the door enabling loops. These loops verify the position of the train relative to the platform and which side the doors should open. Once all this is complete, the ATO will open the doors. After a set time, predetermined or varied by the control centre as required, the ATO will close the doors and automatically restart the train if the door closed proving circuit is complete. Some systems have platform screen doors as well. ATO will also provide a signal for these to open once it has completed the on-board checking procedure. Although described here as an ATO function, door enabling at stations is often incorporated as part of the ATP equipment because it is regarded as a "vital" system and requires the same safety validation processes as ATP.

Once door operation is completed, ATO will then accelerate the train to its cruising speed, allow it to coast to the next station brake command beacon and then brake into the next station, assuming no intervention by the ATP system.

4.8. AUTOMATIC TRAIN CONTROL (ATC)

4.8.1. Introduction

A brief description of the architecture used by ATC (Automatic Train Control) systems.

4.8.2. Definition of ATC

To the UK reader, the letters ATC refer to "Automatic Train Control", which was the title given to the warning system tried on some UK lines before the general introduction of the [AWS \(Automatic Warning System\)](#) in the 1960s. In the US it also refers to Automatic Train Control but it refers to a more modern concept where the system includes [ATP \(Automatic Train Protection\)](#), [ATO \(Automatic Train Operation\)](#) and ATS (Automatic Train Supervision). It has been adopted around the world to describe the architecture of the automatically operated railway. Of course, it is usually applied only to metros. This page looks at the relationship between the four different automatic train concepts.

As a definition, ATC (Automatic Train Control) refers to the whole system which includes all the other automatic functions and, for some of these functions at least, also includes a degree of manual intervention. ATC therefore, is the package which includes ATP, ATO and ATS.

4.8.3. The ATC Package

There are a number of ways to assemble the parts of an ATC package but a common format used by many systems looks like this:

The diagram shows the basic architecture of a fixed block automatic train control (ATC) system with its three main components - ATP (Automatic Train Protection), ATO (Automatic Train Operation) and ATS (Automatic Train Supervision). The basic safety requirement, to keep trains a safe distance apart, is performed by the ATP, which has a control unit for each block. This control unit receives the data from the blocks ahead, converts that into a speed limit for the block it controls and sends the speed limit data to the track. The train picks up the data using the codes transmitted along the track. The transmission system can be track circuits, loops or beacons (balises) located along the track. For more details see [ATP Code Transmission](#).

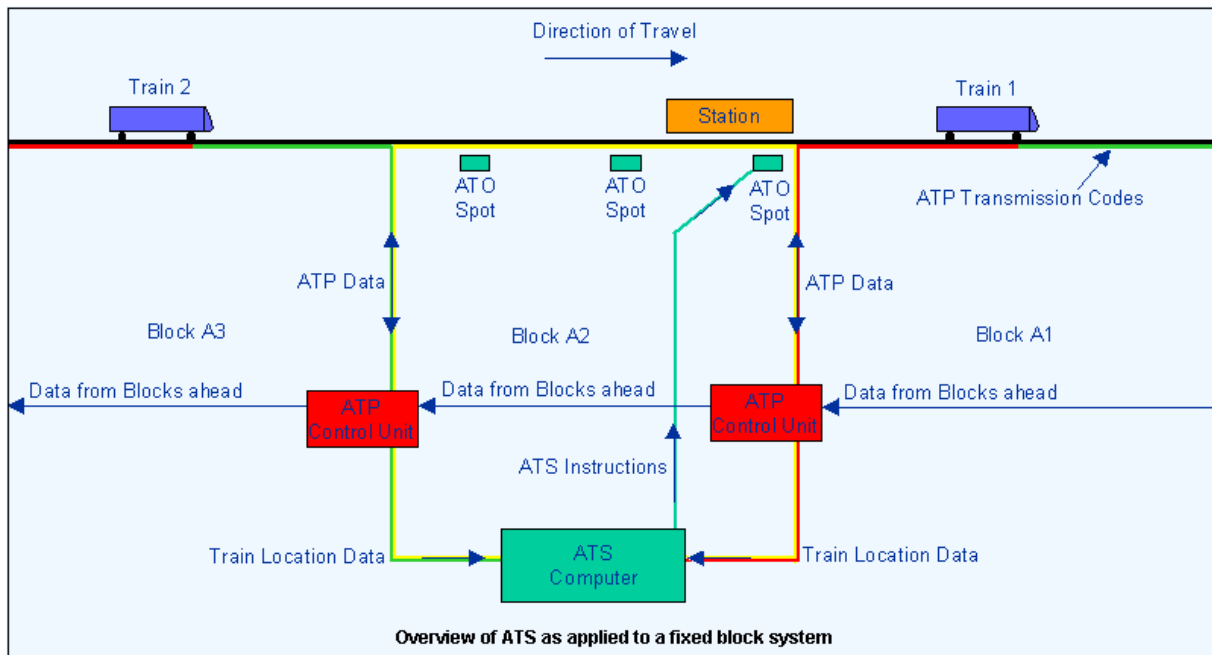

The data received by the ATP control unit is usually limited to indicating that a train is in the block or the speed limit currently imposed in the block. This data is sent to the ATS computer where it is compared with the timetable to determine if the train is running according to schedule or is late or early. To adjust the train's timing, the ATS can send commands to the ATO spots located along the track.

The ATO spots, which can be short transmission loops or small boxes called beacons or "balises", give the train its station stop commands. The spots usually contain fixed data but some, usually the last one in a station stop sequence, transmit data about the time the train should stop (the dwell time) at the station and may tell it how fast to go to the next station (ATP permitting).

Some systems leave the ATO spots alone - i.e their data is always fixed - but use the ATP system to prevent the train from starting or restrict its speed. The ATS computer tells the ATP control unit to transmit a restricted speed or zero speed to the track.

Both ATP and ATO commands are picked up by aerials on the train and translated into motoring, braking or coasting commands. Where a train can be manually driven, the ATP will still ensure the safety requirement but the ATO is overridden, the driver stopping the train in the stations by use of the cab controls.

There are lots of variations of ATC around the world but all contain the basic principle that ATP provides safety and is the basis upon which the train is allowed to run. ATO provides controls to replace the driver, while ATS checks the running times and adjusts train running accordingly.

4.8.4. Moving Block

There is little difference between fixed block and [moving block](#) as far as ATC is concerned but the architecture will look something like this:

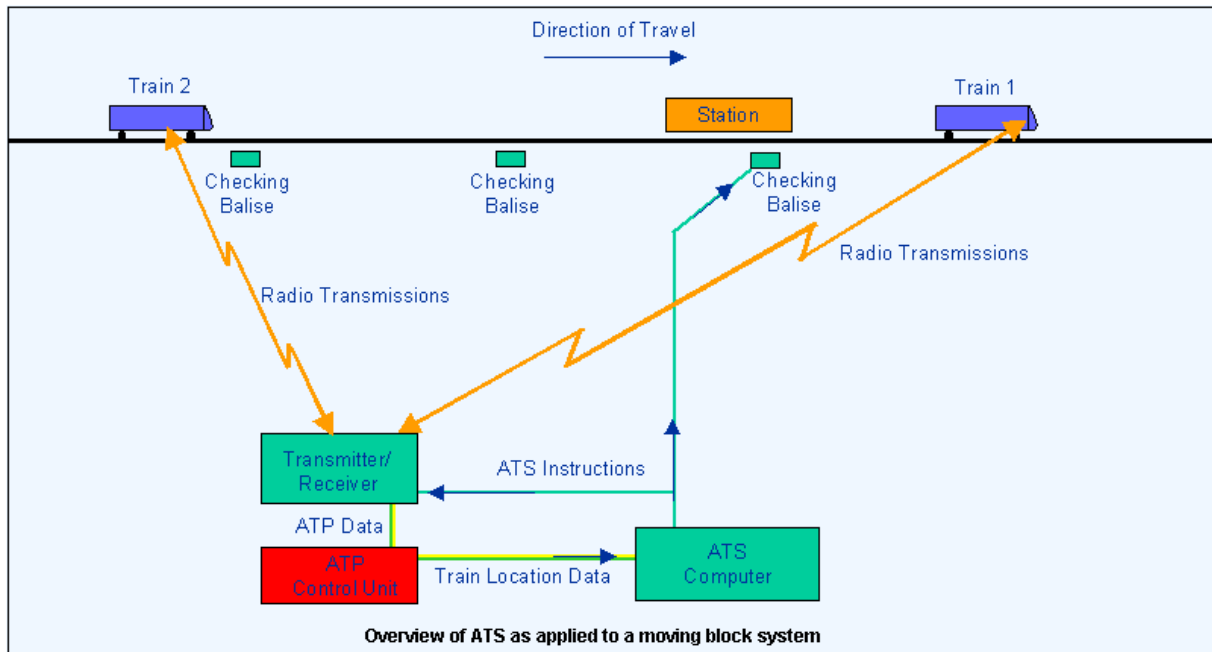

The transmission of data to the rails is gone and is replaced by radio transmission. Also, there are no blocks. The train's location is determined by the on-board route map, which is reset when the train starts its trip and is verified by "checking balises" spaced along the route. The balises can be used to send ATS instructions to the train but, like the ATO spots used in fixed block systems, they contain static data about location and route profile.

In a moving block system, the ATP control unit differs from that used in a fixed block system. It now covers a larger area and it gets its data from the radio transmissions. It sends data by radio as well. If the radio transmission fails to reach a train, this train assumes that the train in front has stopped at its last known position and will stop a safe distance behind it.

ATS covers the same functions as for fixed block systems. Train location data is received and train running adjusted as necessary. In all ATS systems nowadays, there is lots of data logging to provide management information and statistics and some ATS systems allow replays of sections of the day's train movements to assist in formulating future recovery management strategies.

There are some variations on the general principles mentioned above and these are noted in the article on [Moving Block](#) signalling.

4.9. ROUTE SIGNALLING

4.9.1. Junctions

Signals are provided at junctions for two reasons; first to inform the driver that the route is set for his train and second to ensure that no conflicting or unsafe moves are made through the junction. This diagram (Figure 1) shows a signal (C1) protecting the route through a diverging junction. In UK practice, a diverging route indicator is provided over the standard signal aspects in the form of a row of 3 or 5 white lights. If the route is set for the branch, the driver will see a green aspect and the 5 white lights. For the main line, he will see only the green aspect. Some other railways use separate red and green aspects for each route.

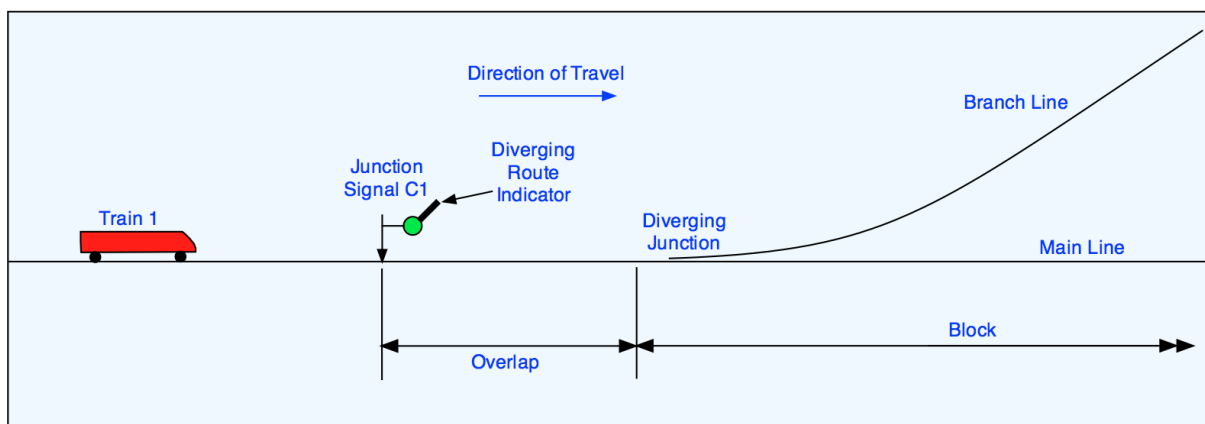

Figure 1 - A Junction Signal

The junction signal is often placed at least 185 metres from the junction or, in the case of a railway equipped with ATP, a safe braking distance. The signal has to perform two functions - to confirm to the driver that the route is set and the points locked for the indicated route and that the block ahead is clear. Once set for the required route, the points are mechanically locked in position and this position is electrically detected to provide the status information to the signalling circuits. This information will prevent a conflicting route being set up.

Some junction signals are set up to show a green aspect for the main route and a yellow aspect for a diverging route, so that the driver is given a warning of a speed reduction being required for the diverging route as well as the white lights.

4.9.2. Route and Track Locking

Once a driver has been given a clear signal indicating a route, it is essential that the route is not changed before the train has completed the manoeuvre through the route and it has completely cleared it. To prevent the route being changed once a train is committed to it, the section of track on the approach side of the signal becomes locked

as the train reaches it to prevent the route being changed within the safe braking distance on the approach to the signal. In addition, the route between the signal and the points is "route locked". Once this track circuit is occupied the point control is locked and the points cannot be moved.

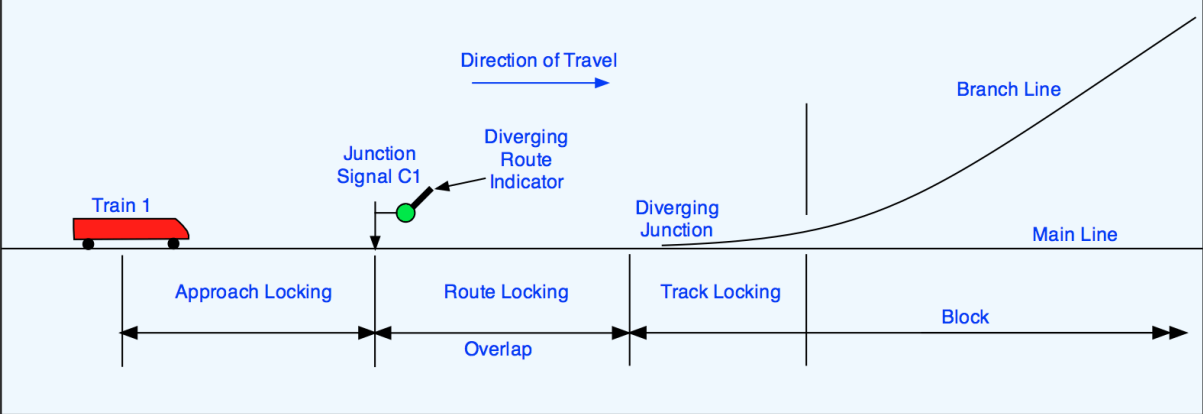

Figure 2 - Approach, Route and Track Locking

Track locking is another safety device employed at junctions. Here, the track circuit at the points is also interlocked with the point operation system to prevent any movement taking place while the train is passing through. Normally the track locking circuits are very compact so that they can be released as soon as the last set of wheels of the train has cleared them and a new route can be set up if required. Speed of track clearance at junctions is very important if frequent services are to operate through them without delay.

4.9.3. Signals at Junctions

Here is an example of a double track junction with points C4 and C5 set and locked to allow trains to pass in both directions over the branch line. Signal C2 will only show a green aspect if the points C4 are set and locked for the route from the branch to the main line and Signal C3 is at red. In this situation, Signal C1 may show a green only if the points C5 are set for the branch.

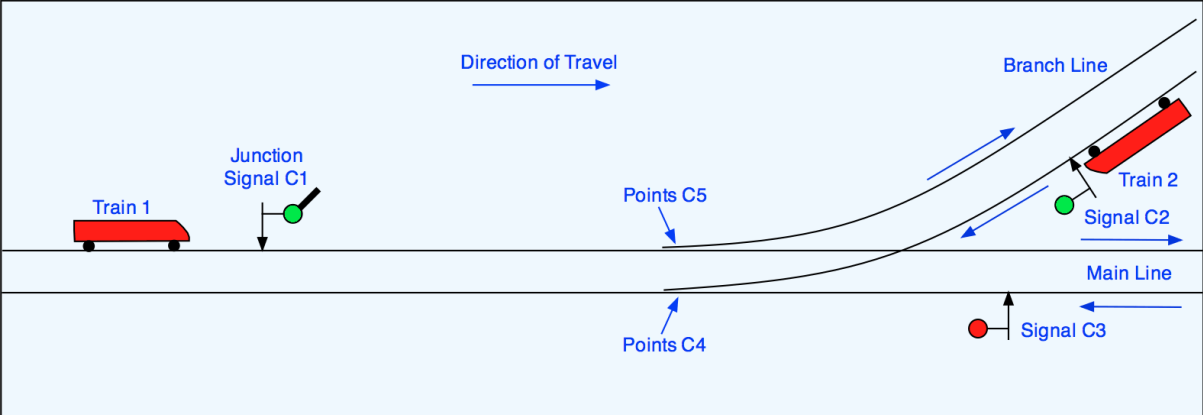

Figure 3 - Signalling at a Double Track Junction

One of the techniques at busy junctions of this type is to schedule trains so that those using the route to and from the branch pass at the same time and trains to and from the main line also pass each other at the junction. This avoids trains being held up unnecessarily because of conflicting moves.

4.9.4. Interlocking

Points and signals at junctions must operate in harmony to ensure that no unsafe moves are set up. The process is known as "interlocking". In the example below (Figure 4), Points C4 and C5 must be set to allow Train 1 to proceed to the main line. Points C4 are used to provide "flank protection" to ensure that Signal C2 cannot be cleared. Points are normally set in this way to provide such protection even if there is no signal to block.

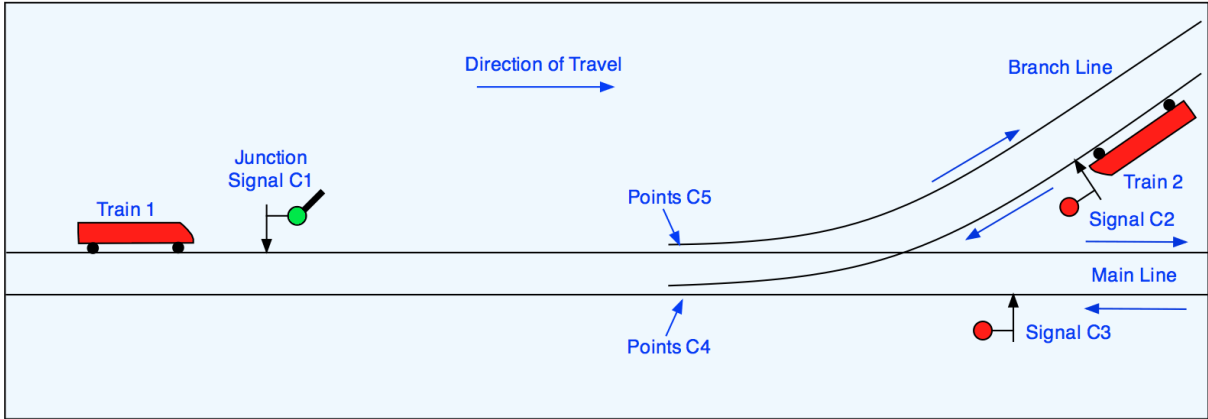

Figure 4 - Interlocking. In this case, the interlocking could allow Points C4 to be set for the main line route and permit Signal C3 to show a proceed aspect.

In some places, the term "interlocking" is used to denote an area controlled by a signal cabin or by a computer. Originally, interlocking was done by a combination of mechanical connections to the operating levers and electro-magnetic relays controlling signals. Nowadays, most new systems employ "solid state interlocking" (SSI - sometimes referred to as CBI, computer based interlocking) using modern electronics instead of relays or mechanical links.

4.9.5. Route Signalling - The Signaller's Display

Modern signal installations use computers for control and screens to display the data for the signaller. Commands, formerly by levers or push buttons, are by trackball or mouse and train identification is displayed automatically as train pass through the routes. The principles for interlockings remain the same regardless of the man-machine interface. The following descriptions relate to recent UK practice.

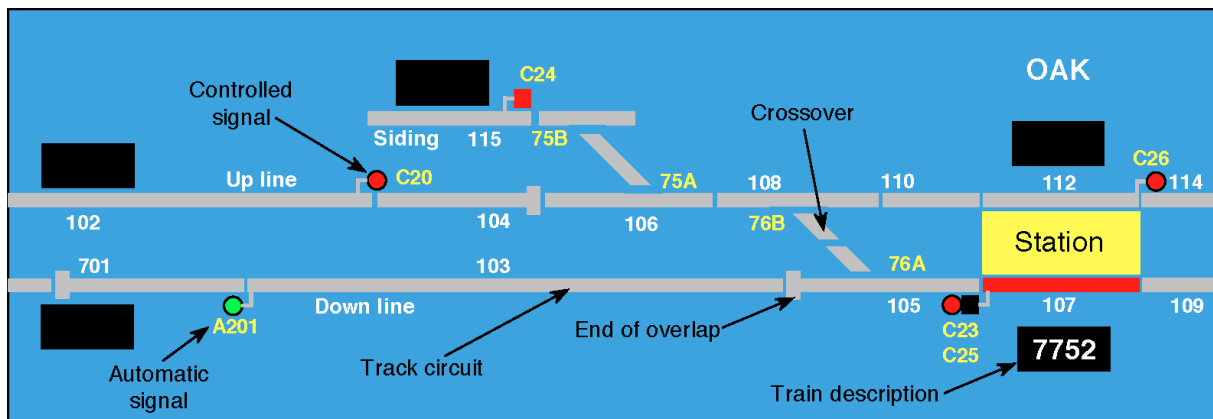

Figure 5 - Screen Shot of Signalling Layout Display in Control Room

In this screen shot of part of an interlocking (Figure 5), unoccupied tracks are in grey, tracks occupied by trains are in red. Each track circuit is given a unique number, as are signals and points. Some signals along plain sections of track are designed to work automatically as trains pass by. Others are controlled from a signal box or control room. Points are numbered in pairs (in yellow) where there is a crossover and they must operate together. Point numbers are provided with letters A or B to denote the ends of the crossover. Train 7752 (its ID, or "description", being displayed in a black box) is standing in the platform of Oak station on track circuit 107 awaiting permission to proceed. Signal C23 is showing a red aspect because no route has been selected and locked. The black square next to the red of C23 is the indication for shunt signal C25 covering the route into the siding. Overlaps are indicated in modern installations by a mark at the end of the track circuit concerned.

4.9.6. Route Set-up

In Figure 6, train 7752 is scheduled to depart on the Down line. The signalman has set up the route and his action is confirmed by the white track circuits along the route showing it is selected, available and locked. The icon of signal C23 is showing a green aspect to indicate that that the signal has cleared.

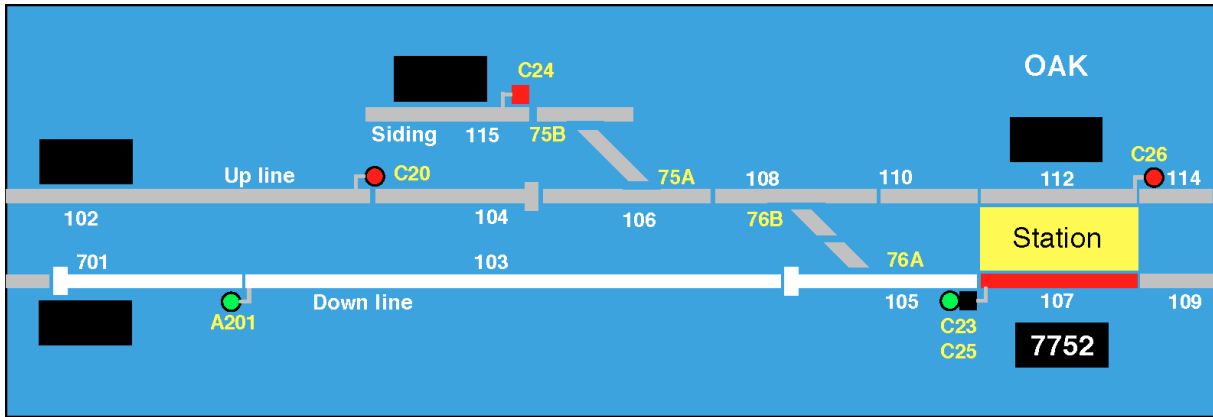

Figure 6 - Route Selection

Signals C23/C25 are approach locked. This means that routes over which they "read" cannot be set up unless track circuit 107 has been occupied for, in this example, at least 30 seconds. This ensures that a train occupying this track circuit has come to a stop and will not run onto the points while they are being changed.

Although the route is cleared, the train description will not normally be shown in the black box over the block ahead until the train occupies the block. Signal A201 is automatic and will always show a green aspect if the line ahead is clear for normal speed.

4.9.7. Train Movement Sequences

In Figure 7, train 7752 has started and is now occupying track circuit 105 as well as 107. Signal C23 has returned to danger. Remember that the diagram seen by the signalman is not to scale so that track circuit 105 is a lot shorter than 107. This will distort the view of the passage of the train. An experienced signalman gets used to it.

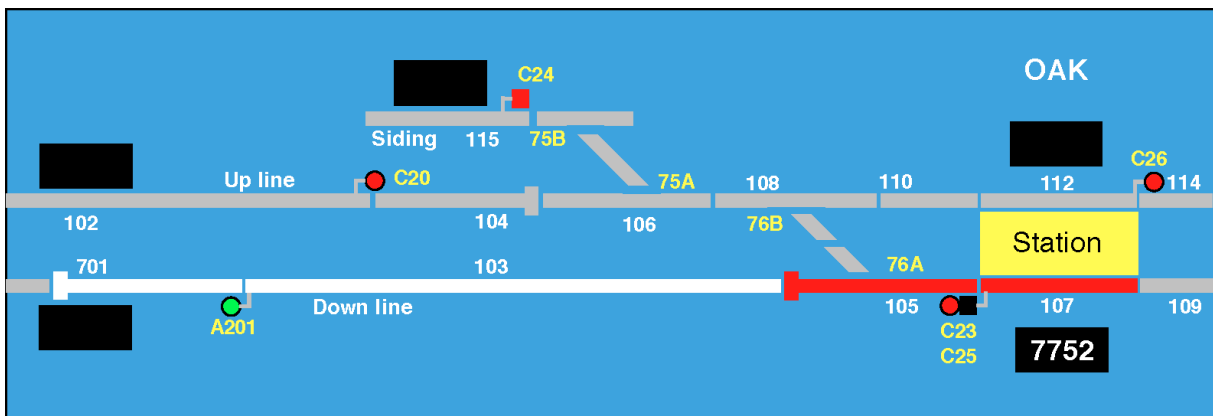

Figure 7 - Route occupation display

Note that the track circuit for crossover 76 has been split into two parts, even though the points at the two ends must be set and locked together for the crossover move. The splitting of the track circuit allows trains on the up and down lines to pass freely.

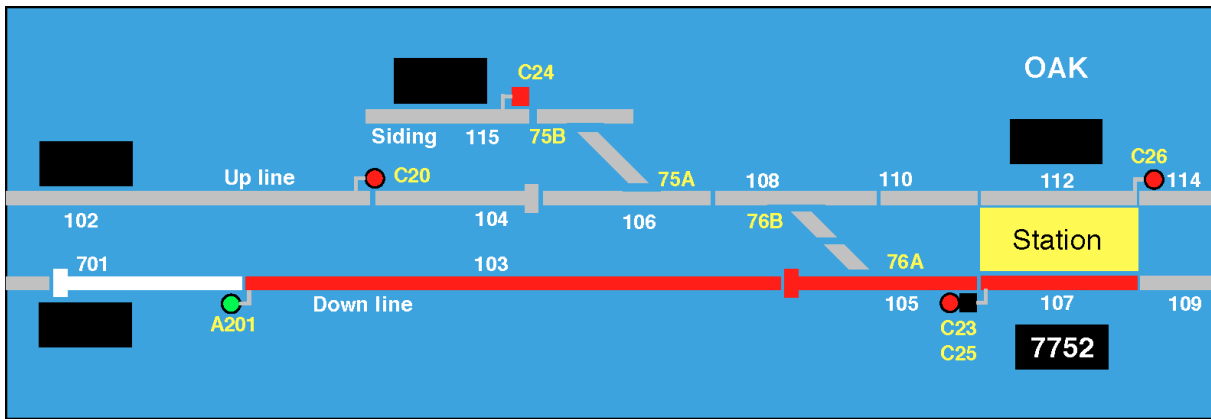

Figure 8 - Tracking the movement of the train

In Figure 8 above, train 7752 is now occupying track circuits 103, 105 and 107. The distortion of the apparent train length is even more evident now. Remember that, as soon as the first pair of wheels of the train enters the section, the track circuit detects them and switches to "occupied", hence the whole of 103 shows red.

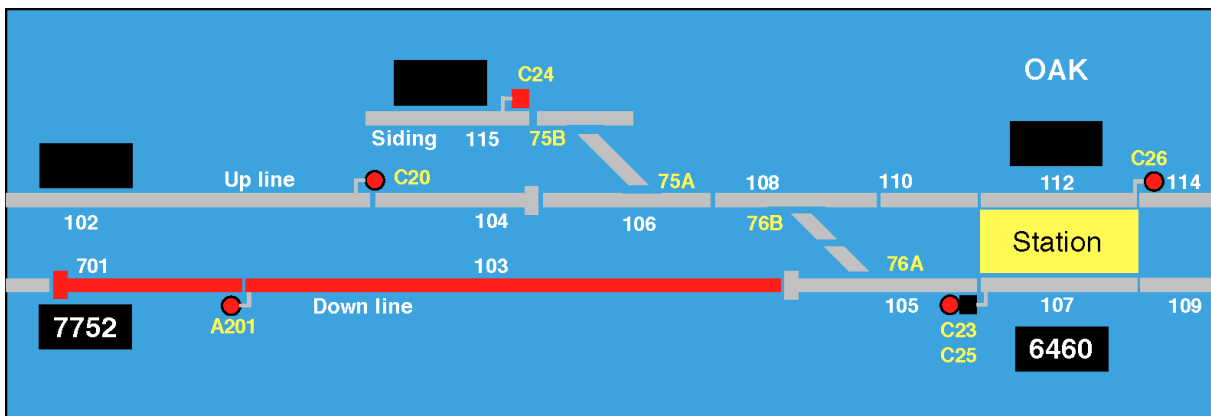

Figure 9 - The train has released the points

Train 7752 (Figure 9 above) has now moved on some distance and the signalman's view of things has changed to match. The train is clear of the platform and points and is occupying track circuits 103 and 701. The points are released to allow another route to be used.

Now that Train 7752 has cleared the platform its description has been cleared from the train description box and a new number, 6460, has appeared. This is the number of the next train to arrive at Oak. The signalman will know from the timetable that this train is scheduled to go into the siding and he must arrange the necessary route changes.

More Trains Arrive

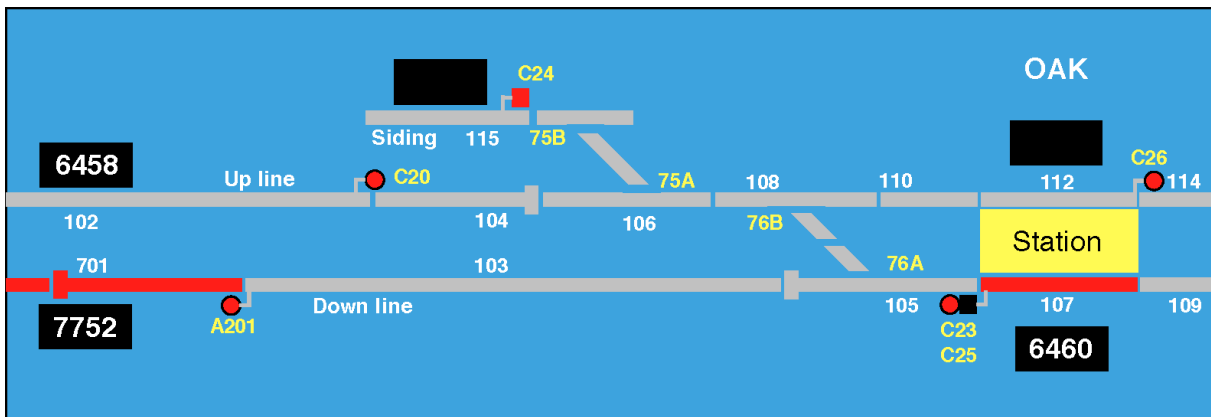

Figure 10 - Two trains are displayed

Figure 10 shows that train 6460 has now arrived at Oak and is supposed to terminate there. Passengers must be detrained and the train checked to ensure no one gets taken into the siding. While this is going on, an Up train, 6458, has also appeared on the "diagram". According to the timetable, this train should arrive at Oak before 6460 but it is running late. The signalman now has to make a choice.

He can set up the route for 6460 to get him into the siding and clear the down line. He wants to do this because there is another train due behind 6460 and he doesn't want to delay it. On the other hand, he doesn't want to cause 6458 to be delayed further while 6460 crosses in front of it to reach the siding.

So, if he lets 6460 into the siding first, will it be quick enough to allow 6458 a clear run in? He will chance it because he knows from experience that the driver will want to get the train stabled quickly because it is the end of his duty.

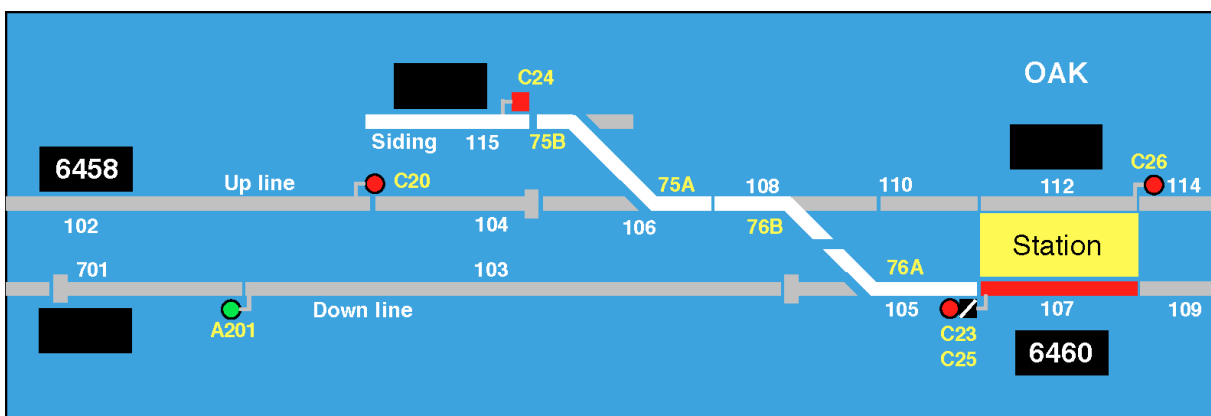

Figure 11 - A second route is selected

The signalman has decided to move Train 6460 into the siding across the path of 6458 and he has set up the route as shown in Fig 11. The white track circuit displays show that

the route is set up and locked. The white diagonal on the icon of shunt signal C25 shows that the signal is showing proceed to the driver of Train 6460.

The Third Train Arrives

Time has moved forward a few minutes (Fig 12) and the signalman (to his annoyance) has seen no movement from Train 6460. However, by this time, Train 6458 has arrived on Track Circuit 102 and is standing at Signal C20. Already late, he will now be even later waiting for 6460 to clear the route.

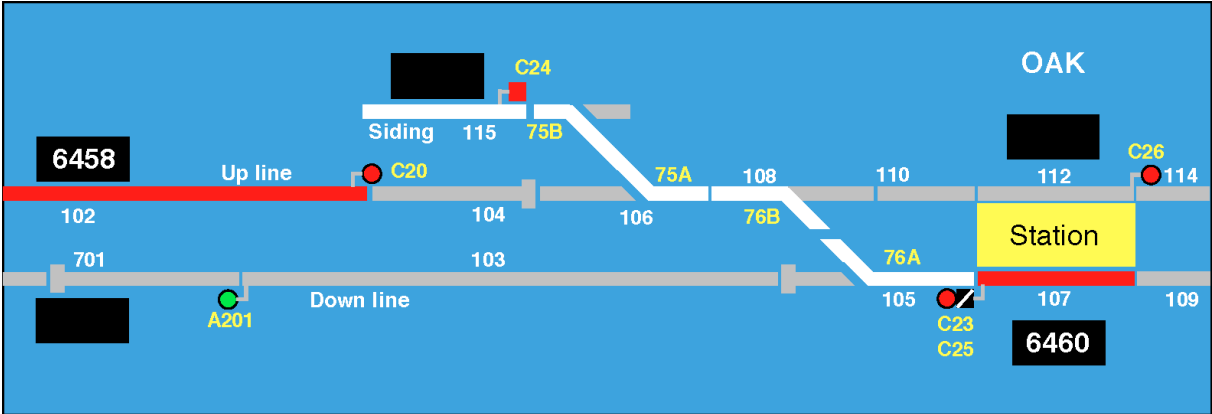

Figure 12 - The third train arrives

The signalman has another choice to make. He can cancel the route set up for Train 6460, wait for it to "release" and then set up the route for 6458 to run into the platform or he can wait for the original move of 6460 to be completed.

If he cancels the route for 6460, the signalman must wait for it to "release" before another route can be set up. A release is an electronic timer usually set for two minutes. This is to ensure that no train moves on to a track circuit immediately after the signal has returned to red. This could happen if a driver sees a proceed aspect and starts his train, only to see the signal return to danger and finds he cannot stop before occupying the route.

The Next Move Begins

Now, at last in Figure 13, Train 6460 has begun to move. The signalman had phoned the platform staff to see what was holding up 6460 and was told they had trouble clearing the train. Someone didn't want to get off but it's now OK after they were told the police were to be called and the train will move. It has.

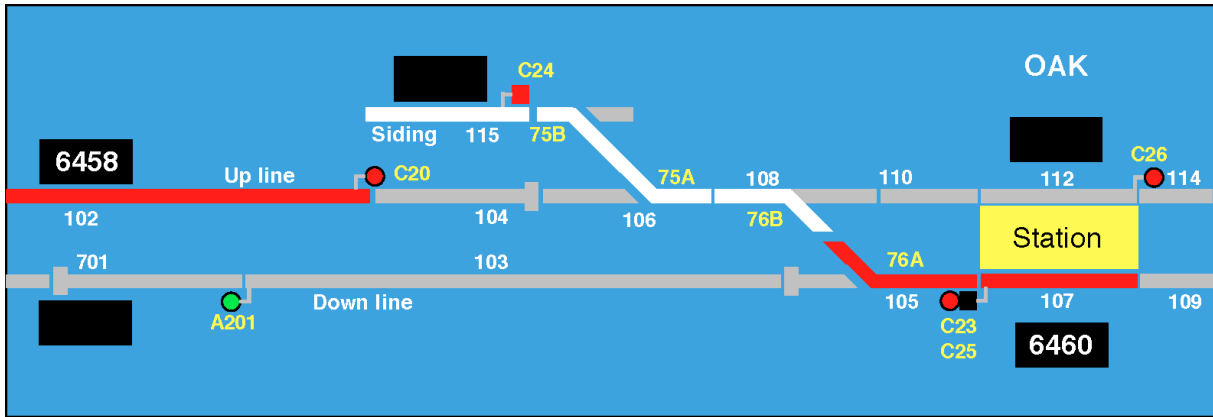

Figure 13 - Train 6460 moves towards the siding

You will see how track circuits at points reflect the layout of the points and indicate that the points are "track locked" as the train passes over them. Although 76 crossover actually has two separate track circuits, the points at each end of the crossover operate as a pair. As mentioned above, the separate track circuits are to allow trains to pass on the Up and Down lines without interference.

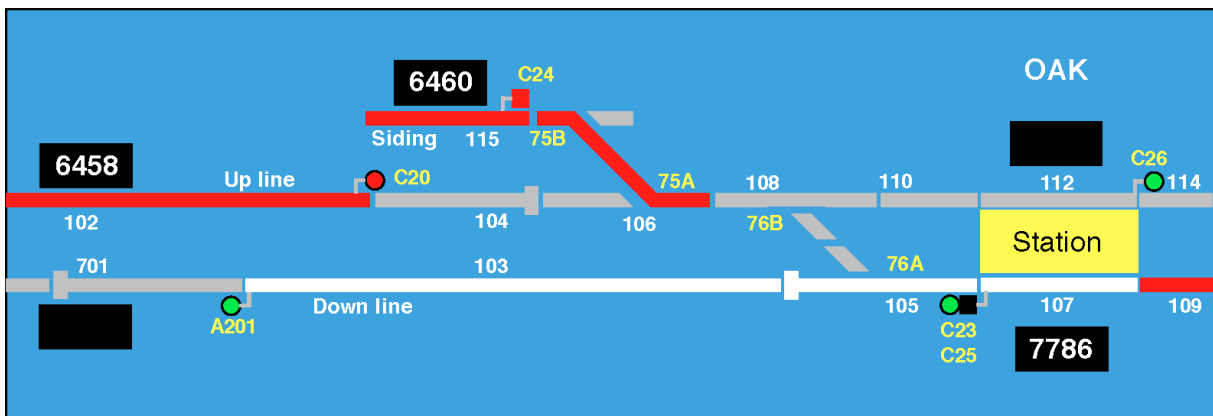

Figure 14 - The third route is set up

In Figure 14, train 6460 is now clear of 105 and 108 track circuits and the signalman has set up another route, the Down line route for the next train 7786, as indicated by the white track circuits. Signal C23 shows a proceed aspect. Train 7786, has already approached the area, occupying Track Circuit 109 and has been signalled all the way through the area.

You will see that, although the Down line route is clear for Train 7786, track circuit 701 still shows grey. This is because it is not part of the controlled area. It will only show grey when unoccupied and red when occupied.

Train 6460 is almost clear of the Up line. Immediately 75 points clear, the whole route for Train 6458 will be freed and so that it can be selected as shown on the next diagram (Figure 15 below).

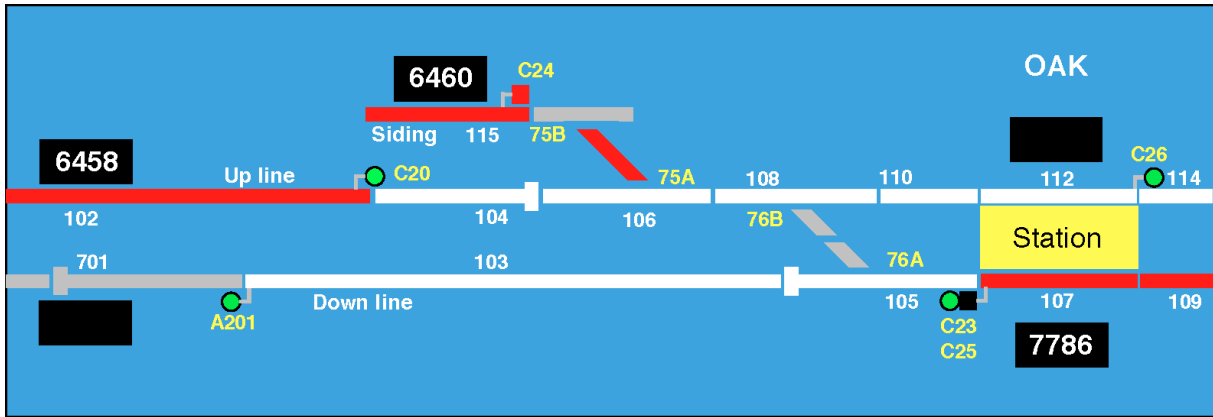

Figure 15 - Two routes freed for Up and Down trains to proceed

Train 6458 now has permission to proceed into the platform and will soon start. Train 7786 is just entering the Down platform.

The above series of screen shots are representations of the sort of indications and train movements typically seen in modern control rooms. Not all installations are designed the same way but the basic principles are the same.

One feature which is apparent with all signalling installations is the need to prepare detailed "control tables" which define the logic sequence required for each route. Much of the work is now computerised but part of the signal engineer's work is to understand the type of operational problems seen here and apply it to the design and control of signalling.

4.10. SINGLE LINE OPERATION

4.10.1. Introduction

Many railways around the world have more single track line than multiple track, so single line operation plays an important part in everyday train working and signalling practices. The normal practice is to provide a single line with passing loops or short double track sections to give trains running in opposite directions places where they can pass. This page gives an overview of the operation of trains over a single line and covers both US and UK practice.

4.10.2. One Engine In Steam

The simplest form of single line operation is where the line has only one train - so called "one engine in steam" operation. This is usually only practicable on a short branch line where the volume of traffic is low enough not to require more than one train. The entrance to the line is protected by a locked manual ground lever frame or remotely controlled track circuited block. In the UK, a "staff" or "token" may be issued to the driver as authority to proceed on to the single line.

4.10.3. Single Line Operation in the US

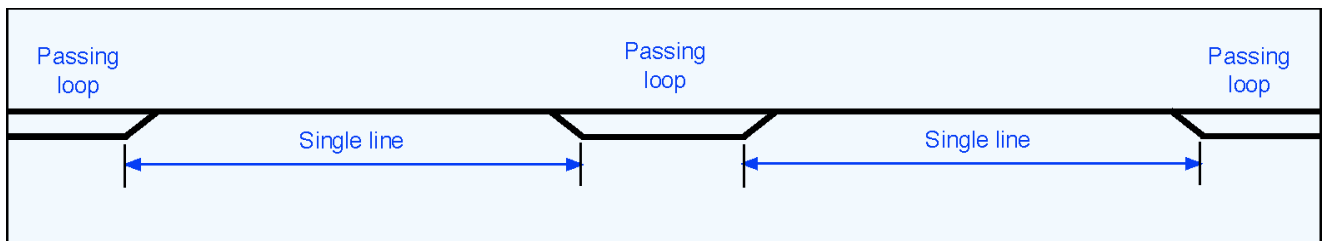

Fig.1: Diagram of typical single line with passing loops. In the US, a passing loop is often referred to as a siding. The length of the loop must allow for the accommodation of the longest train using the route.

Many railways around the world are operated where trains work in either direction over a single line. Trains running in opposing directions pass each other at places where loops or sidings are available (see diagram, left). Obviously, special, and somewhat elaborate precautions are used to prevent head-on collisions, or "cornfield meets" as they are called in the US.

The principal difference between UK and US operation of single lines is that the UK uses lineside signals whereas, over large sections of the country, the US does not. This is changing as more and more US lines come under centralised signalling control known as CTC (Centralised Traffic Control) but there are still huge areas of "dark territory", as it is called, which have no fixed signals. For these areas, special rules are required and they have developed, over the years, into a complex system of train dispatching called "timetable and train order" operation.

4.10.4. The Timetable

The basic authority for train movements over a single line in the US is the timetable. It is used as the first level of regulation for all trains. The timing and priority for trains is laid down in the timetable, i.e. the timetable dictates the departure times and then, if times cannot be adhered to, which train should move first and which should wait for others. There is normally a set of rules of priority, e.g. "superiority by direction" where trains going in one direction, say westbound, have precedence over trains going eastbound. In such a case, an eastbound train which arrives at a passing loop will always have to wait in the loop until a westbound train or trains has passed. Different types of trains are also given priority, passenger over freight, for example. Dispatchers, who are responsible for the movement of trains, always try to conform to the timetable first before issuing a train movement order.

4.10.5. Train Speed Rules (US)

In the US, train speeds are regulated by law according to the signalling and automatic train protection ([ATP](#)) system provided. Trains are only allowed to run at 80 mph and over if ATP is provided in some form. Trains are restricted to below 59 mph (passenger) and below 49 mph (freight) in "dark territory", i.e. where there are no signals. See also [US Railroad Signalling](#).

4.10.6. Train Spacing

There will often be circumstances where one train will be required to follow another in the same direction. Without signals, this can be hazardous unless certain rules are followed. In the UK, single line sections are comparatively short and are protected at each end by signalling but, in the US, they can be very long and without signals. In the US, trains following one another over an unsignalled single line are only separated by time interval.

The normal time interval is five minutes between trains dispatched from a station. If the train fails to keep to the normal speed for that section, the conductor or "flagman" will drop a flare (called a fusee) with a five minute burn time. The following train is not allowed to pass this flare while it is still alight. If his train stops, the rear conductor has to protect the train by walking back a safe braking distance and laying detonators (called torpedoes in the US) and showing a red flag or light to following trains. This is similar to the emergency protection used in the UK.

4.10.7. Train Orders

Time interval operation is not used in isolation. The basic form of authority for single line operation is the Train Order. This is a written instruction passed to the train crew which tells them they may pass onto the specified single line section and proceed along it until

its end or a loop or siding is reached. Once there, the Train Order will indicate whether they must wait for a new order or wait until a train running in the opposite direction has passed before they can proceed further. Train Orders have formed the basis for train movement control in North America since the 1850s.

Train Orders were traditionally always issued as a written paper which was handed to the crew. Dispatchers were in charge of issuing TOs since they has the overall picture of the section of line under their control. Communications between dispatchers were originally by electric telegraph using Morse code. Later, telephones became the standard method. If orders were changed along the line, a train could be stopped at a station by a manually operated fixed signal. This signal was only an indication to the driver that he should stop and collect a new TO.

4.10.8. Track Warrants

In recent times, radio has become the standard method of issuing train orders. Instructions are passed to crews by radio and the driver copies his instructions onto a special sheet called a Track Warrant.

Burlington Northern Track Warrant	
Number _____ to train _____ at _____.	
1. <input type="checkbox"/> Track Warrant # _____ is Void. 2. <input type="checkbox"/> Proceed from _____ to _____ on <input type="checkbox"/> Main <input type="checkbox"/> Siding. 3. <input type="checkbox"/> Meet _____ at _____ and take <input type="checkbox"/> Main <input type="checkbox"/> Siding. 4. <input type="checkbox"/> Meet _____ at _____ and take <input type="checkbox"/> Main <input type="checkbox"/> Siding. 5. <input type="checkbox"/> Track and Time in _____ from _____ m to _____ m. 6. <input type="checkbox"/> Not in effect until _____ m. 7. <input type="checkbox"/> Not in effect until <input type="checkbox"/> arrival <input type="checkbox"/> departure of _____. 8. <input type="checkbox"/> Between _____ and _____ proceed at restricted speed. Limits occupied by train or machines fouling track. 9. <input type="checkbox"/> Other Instructions: _____ _____	<div style="text-align: center; font-weight: bold; margin-bottom: 5px;">East</div> LC La Crosse BP Brice Prairie EW East Winona CO Cochrane AL Alma PP Pepin BC Bay City <div style="text-align: center; font-weight: bold; margin-top: 5px;">West</div>
OK at _____ m by Dispatcher _____ Released at _____ m by Conductor _____	

Fig. 2: Sample Track Warrant form (BNSF).

The driver will repeat back the message to the dispatcher to ensure the message has been properly understood. This elaborate system is essential to ensure that the correct messages are received and understood by the designated crew. A summary of how the system works is as follows.

4.10.9. Unsignalled Operations in the US

The system used on most unsignalled lines in the US is called the Dispatcher Control System or DCS. An unsignalled line is broken up into blocks which can be up to 20 miles long. Each block has a Block Limit Station (BLS) at each end. A BLS consists of a simple fixed sign with the name of the BLS on it. Block Limit Stations are usually located away from sidings so that any shunting can be done within the limits of a single block.

Train operation is controlled by a dispatcher. The dispatcher will issue a track warrant called a "[Form D](#)" (on many lines, some call it by other names) to the train over the radio. This will be his authority to proceed. The Form D tells the train which blocks it can be in.

If a "meet" is set up (i.e. trains have to pass each other) the dispatcher will order one train into a loop (called a siding in the US) and, once the crew calls in via radio that they are clear of the main line and hence out of the block, he will issue a Form D to the other train.

If another train needs to follow the first, the dispatcher may instruct the first train to call in via radio each time it passes a BLS. In this way the dispatcher knows which blocks are occupied and, therefore, where trains can run safely. To keep the trains a safe distance apart, the dispatcher will either use time delay at each BLS or will issue a Form D to the lead train and a separate Form D to the following train at each BLS.

Sometimes, lines which have signalling need to use the Dispatcher Controlled System (DCS), for example, wrong way running being required on single direction, automatically signalled tracks.

An alternative description of the use of track warrants is at a useful page called [Track Warrant Control](#).

4.10.10. Centralised Traffic Control (CTC)

The more heavily used single lines are nowadays signalled and remotely controlled from a central location. Track Warrants are largely unnecessary. The signalling is based on track circuits and often allows long single line sections to be broken up into blocks, each protected by a signal at each end. More than one train can proceed in the same direction, fully protected by automatic signalling.

4.10.11. Single Line Operation (UK)

In the UK, single line sections were generally short and were normally controlled by signalmen. Under manual operation, trains were admitted to the single line once the signalman at its entrance had confirmed with the signalman at the exit that the previous

train had cleared the other end. Various systems were used and many can still be seen on local or preserved lines today.

4.10.12. Staff and Ticket System

The original process for single line operation was known as the "staff and ticket" system. Authority to enter the single line was by the signalman at the entrance giving the driver a "staff", a rod of wood or metal, on which the name of the single line was stamped. When the train arrived at the other end of the single line, the staff was given up to allow a train to proceed in the opposite direction.

If more than one train was required to follow consecutively in the same direction, the first and subsequent trains were given a "ticket", which was analogous to the US train order. It detailed the train information and the section over which it was allowed to pass. When the ticket was issued, the staff was also shown to each driver as a guarantee that the issue was OK. The staff was carried by the last train of the batch going in that direction.

4.10.13. Electric Token Block

From the late 1880s, various forms of electrically interlocked, single line token systems were introduced. The signal box at each end of the section was equipped with a "token instrument". This was a machine which detected the removal or replacement of a "staff" or "token". The token was a metal key which was smaller than a staff but which performed the same function. The token instruments at each end of a single line section were electrically interlocked so that the act of removing a token locked both machines and prevented further removals from either instrument until the missing token was replaced at one end or the other. To allow the passage of two or more consecutive trains in the same direction, the system used more than one token. In effect, the "staff" and "tickets" now became a set of metal tokens. In some systems, a set of "staves" were used as tokens.

It worked like this: The signalbox at each end of the line had lots of tokens. They were stored in the token instrument. A token for authority for passage along a single line could only be removed by the signalman at the departure end if the signalman at the receiving end pressed a plunger which released the token on the departure end instrument. When the token was removed from the instrument at the departure end, the instruments at both ends became locked. Both remained locked until the token was replaced in the receiving end instrument. If a second train had to follow the first, a second token was released by the receiving end signalman as before and removed from the departure end, locking both instruments again until it was inserted in the instrument at the other end.

Because it was a system relying on electric locking it was called the electric token system.

The next evolution was called "tokenless block" working, where the signals at each end of the single line were themselves electrically interlocked. The signalman could not clear any signals protecting the entrance to the single line as long as the signals at the other end had admitted a train. A direction lever was provided at each end and they had to match each other to enforce the locking.

4.10.14. Radio Electronic Token Block (RETB)

The development of modern electronics and "vital" or secure radio transmission systems has allowed railways to develop more cost effective signalling. In rural areas of the UK, where long sections of single line require token block operation, a system for centralised control, using modern computer technology, was adopted. It is known as Radio Electronic Token Block (RETB).

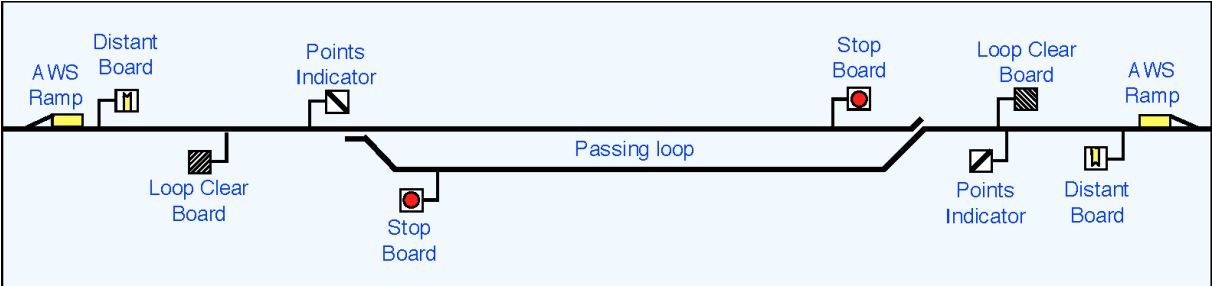

Fig.3: Diagram of route with Radio Electronic Token Block system

At a number of locations in the UK, this system (Fig.3, above) has been in operation for over 10 years and allows one signalman to control several single line sections between passing loops. One installation in Scotland controls over 100 miles of railway.

Each train operating over the single line is equipped with a special speech and data radio transmitter/receiver with a unique identity. At the start of the single line, the driver stops and calls the control centre for authority to enter the section. If the line is clear, the signalman in the control centre transmits a coded "electronic token" data message which is received by the train and then shows the authority for that section on a cab display. The driver will then call for confirmation that he can enter the section. Once in the single line section, he will advise the control centre that he has cleared the loop track. A clearance marker board is specially provided to help him. When he has reached the end of the single line section, the driver calls the control centre again and offers to give up the token. After a "handshake" procedure by the control centre, he sends the token back by radio data transmission to release the section.

The signalman is provided with a computer controlled radio system which allocates the coded tokens to each section and prevents more than one token being issued for an occupied section. It also receives the tokens sent back by each train as it reaches the end of the single line section. At the exits of the single line sections, the points are permanently set in the direction of normal running and are "trailable" for trains entering the section, i.e. they allow a train to pass through at reduced speed using the wheel flanges to move the point (switch) blades aside reset to the normal position.

A "Distant Board" complete with [AWS ramp](#), warns the driver that he must slow down for the movement over the points leaving the single line. The Points Indicator shows the position of the points. A "Stop Board" at the end of the passing loop warns the driver to stop and ask for permission to enter the next single line section. The "Loop Clear" board shows when the rear of the train is clear of the points.

An excellent description of the operation of RETB is available at [The Modernisation of the Cambrian Lines](#) by Alan Jones on the Signal Box Site. Of course, this system is now being superseded by the test installation of ERTMS on the route.

Additional information on US single line operations supplied by "Evil Mike".

4.11. US RAILROAD SIGNALLING

4.11.1. Basic Differences (UK-US):

a-Signal Meanings

On railways all over the world, signals are used to indicate to the driver of a train how he should proceed. The way this is done in the US (and most of Europe except Spain and Norway) is quite different compared with the UK. In the UK (and other countries using UK based systems), signals are designed to show the driver the state of the road ahead. For example, a signal will show that the line is clear ahead and will also say how far ahead it is clear. The driver, using his knowledge of the line and of the train he is controlling, will make a judgement about how fast he can safely let his train go and will proceed accordingly. In the US, signals show drivers the speeds they are allowed to go. They do not actually need to know how far ahead the line is clear. The speed they are allowed to do will depend on the type of train the driver is controlling.

b-ABS and Interlockings

In the US, like the UK, signals are classified into two general types. In the UK they are referred to as automatic and controlled, in the US they are known as Automatic Block Signals (ABS) and Interlocking signals respectively. The two classifications are similar in that automatic signals work without manual controls while controlled or interlocking signals usually cover junction areas and require some form of additional controls operated by a signal tower (signal box in UK) or control room.

c-Overlap or Safety Block

Another feature of US railroad signals is that they do not have the 200 yard overlaps that are normal in the UK. The usual method of providing a safety margin beyond a stop signal in the US is to allocate the whole of the next block as the overlap. This is similar to the principle adopted on [metros which use ATP](#).

d-Bi-Directional Signalling

Many US lines are equipped with full bi-directional signalling. You will often see a block boundary with two signals, one facing in each direction. The signalling operates exactly the same, regardless of the direction of running.

e-ATS, ATC, CSS

Any operator in the US who wants to run trains over 79 m/hr has to have some sort of automatic train stop (ATS), automatic train control (ATC) or cab signalling system (CSS). These names all mean that the driver gets some sort of in-cab indication and a warning

of signal conditions. There are basically two systems; those which provide a warning like the UK [AWS system](#) and those which regulate speed, like an [ATP system](#).

f-Dark Territory

In the US, there are still large sections of lines which have no signals. This is almost unheard of in Europe because train traffic is normally a lot more dense. In the US, the unsignalled lines are usually long, single line sections in remote areas and there are thousands of miles of them. They are commonly referred to as dark territory. Trains are permitted to pass from one area to another by the use of [train orders](#) or [track warrants](#), nowadays transmitted by radio between dispatchers and train crews. Passing loops, called sidings in the US, usually form the boundaries between areas. There are elaborate rules for ensuring safety and accidents are rare.

g-Single lines with Signals

Some single line sections in the US are equipped with ABS (automatic block signals) to allow two or more trains to follow each other closely along the single line between sidings. The signals are provided for both directions as shown in the diagram below. Often, the entrances to sidings are not controlled by interlocking signals and turnouts for sidings (passing loops) are hand operated.

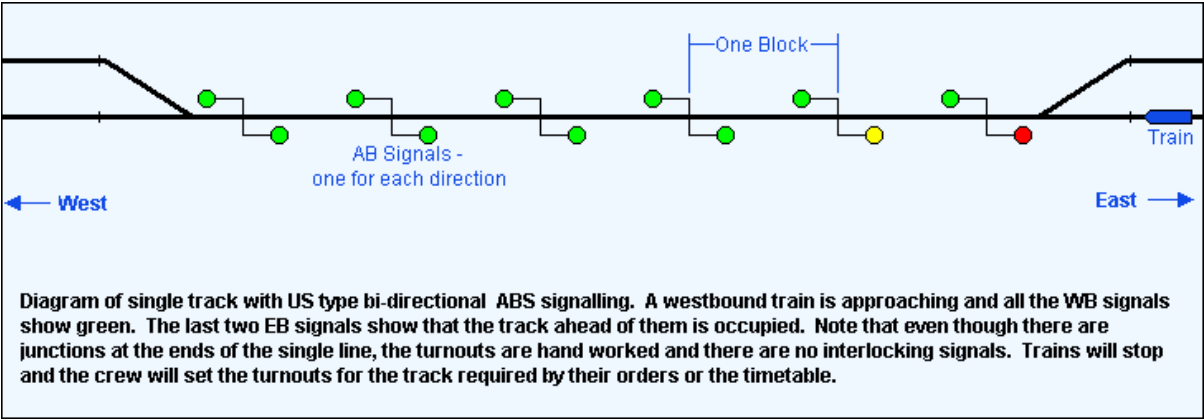

There are no signals at the entrance to the signal line (diagram left). The crew will be given authority by [Track Warrant](#) over the radio to enter the single line and then they will observe signals. The reason for this type of operation is to allow more than one train to proceed along the single line. Without the signals, successive trains have to follow by time interval, a rule still used in North America but which has not been allowed in the UK for over 100 years.

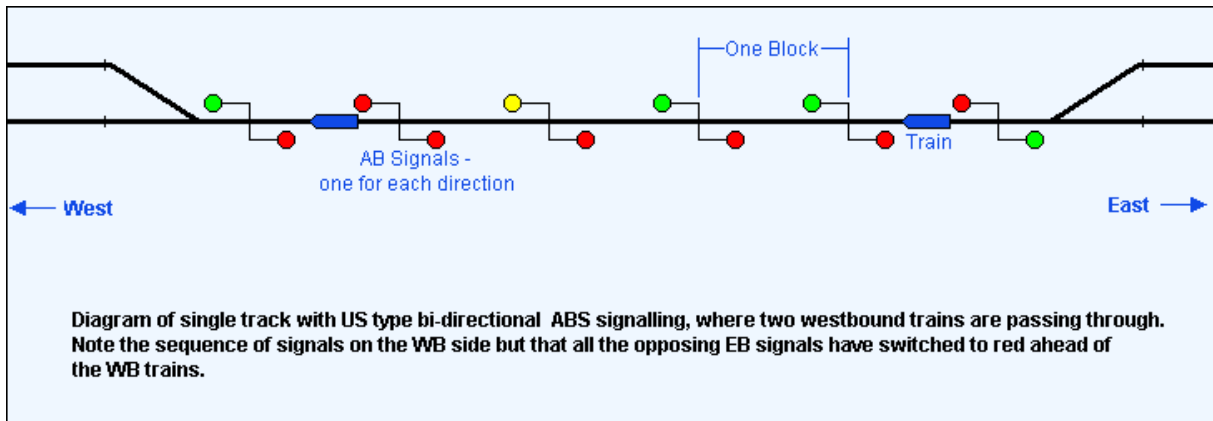

The next diagram shows the sequence of signals as two westbound (WB) trains pass through the single line section. The signal indications are similar in meaning to the British "stop, caution or distant and clear" indications.

h-Turnouts

On single lines in the US, it is not unusual for sidings to be equipped with hand operated turnouts (points), even if the line is equipped with automatic signals. This means that the driver of a train approaching a siding has to stop his train, even if the signal is showing a "proceed" aspect, and operate the turnout by hand to enter the siding.

Some sidings have spring loaded turnouts which are set to ensure that trains from opposite directions enter a different track without the crew having to stop and set the turnout by hand.

i-Operating Philosophy

In the UK, trains have been regulated by fixed signals since shortly after railways were first opened in the early 19th century. As signals in the US were the exception rather than the rule, many railways' rulebooks reflect this in their treatment of the rules. Signals were (and still are in some places) regarded as an adjunct to the railway rather than part of it. With this in mind, we can now look at US signalling in general.

4.11.2. US Signal Layouts

A train passing along a signalled route will see an arrangement of signals which will appear somewhat as described in the following paragraphs. Every 2 miles or so the train will pass an Automatic Block Signal (ABS). All ABS signals for all tracks and both directions are located right next to the block entrance at the insulated rail joint (IRJ). So, as the engineer (driver) passes from block to block its almost like passing through a pane of glass. This is enhanced by the fact that for the most part there isn't much along the wayside but at a block limit he will see signals, relay boxes and rail joints.

OK, the engineer is passing block after block and all the signals have one head but then he gets to a block limit where the signal in his direction has two heads. These are the distant signals for an interlocking. They are still automatic and still retain a number plate that ID's them as automatic. After proceeding a little farther down the line the engineer reaches the interlocking entrance. Across all tracks, in his direction only, is a line of signals. These signals have two or three heads and no number plate, which ID's them as absolute (stop) signals. If there is a proceed indication, the train crosses the boundary defined by the IRJ and signals and enters the interlocking. The train then rumbles over the points, it passes the signal tower or relay shed, rumbles over some more points and reaches the "exit" signals. The exit signals actually have no bearing on this train whatsoever because they are all facing the opposite direction for incoming trains.

The entrance signals not only govern the interlocking, but also the next block. However the exit signals and associated IRJ define another boundary and, after the train completely passes this boundary, is it out of the interlocking, free of dispatcher control and under automatic signal rules. Note that, while any part of the train is between the Home (entrance and exit) signals, it is working under interlocking rules. Once it crosses the boundary defined by the Home signals it is under rule 251 or 261 operation.

The train continues on to complete the same steps through each interlocking. Every so often a train will pass from one interlocking right into another (some interlockings also have sub interlockings that are completely independent). The first ABS limit the train reaches will be the distant for operation in the other direction.

4.11.3. Precedence

In the US, trains are given what is referred to as "precedence". This means that each type of train has a "pecking order" in terms of priority of movement. Precedence is determined first by the timetable, then by the type of train and then by direction. Different railroads have their own precedence rules but the principles are the same.

4.11.4. Train Orders and Track Warrants

The foundation of US railroad signalling philosophy is single line operation without fixed signals. Signalling was only introduced for sections of line which had too many trains to handle under manual rules or where there were junctions. Trains are handled by Train Orders or Track Warrants. An explanation of the train order and track warrant process is in our [US Single Line Operation](#) section.

4.11.5. Signalling Commands

The US Automatic Block Signal (ABS), i.e. one without any manual control and operated by trains passing through [track circuits](#), shows four basic commands. The way they are

shown, in other words the aspect, varies from railroad to railroad and often from division to division in a railroad. There are also variations in the meanings of signals which appear to look the same. The basic commands, however, are:

Stop, Approach, Approach Limited and Clear.

The US has the "stop and proceed" signal system seen in the UK but it is referred to as a "permissive" signal. The driver is told, "You are allowed to pass this signal after stopping but you must proceed at a speed which allows you to stop your train in half the available sighting distance." There are some stop signals at interlockings (therefore they are not ABS) where it is forbidden to pass and these are called "absolute stop" signals. They invariably show a different display to the permissive stop signal and it normally includes two red lights.

As US signals are speed limiting, a signal displaying "Approach" means the equivalent of the UK single yellow - "be prepared to stop at the next signal" but, additionally, the US rule says, "also keep your train speed down to less than 30 mi/h (often less for freight)". "Approach limited" (UK = double yellow) would mean "you should be doing 30 by the time you get to the next signal but not more than 45 mi/h now".

In the US also, there are three common terms used to instruct crews about permitted train speeds. These can be classified as "slow", "medium" and "limited". Slow normally means less than 15 mi/h, medium normally means 30 and limited means 45 (40 for freight) mi/h. There is a fourth "Restricted Speed" which is 15 mi/h inside interlocking limits or 20 outside or the speed which allows you to stop within half sighting distance. It is the speed you are allowed to do if you have passed a red permissive signal.

There is a list of the common signalling rules applied to most railroads in North America at [NORAC Signal Aspects](#). It shows each signal display and the rules appertaining to that display.

4.11.6. Interlocking Signals

Interlocking signals in the US represent the UK "controlled" signal; i.e. one that is controlled from a signal tower (cabin in UK) or any sort of control room. Interlocking signals offer a great variety of signal displays and commands which can be confusing. In addition to signals showing what speed you are allowed to do because of the route which is set for you, there are some which indicate a speed restriction "within interlocking limits".

A sample series of commands looks like this: Note that the commands are all speed related and they cover AB signals as well.

Clear - Proceed at normal speed for your train, you will get the straight route ahead.
 Approach - Be prepared to stop at the next signal and reduce train speed to 30 mi/h
 Approach Slow - Be prepared to stop at the next signal but approach it at slow speed (15 mi/h); usually because of passing through a crossover.
 Advance Approach Medium - Proceed but approach second signal ahead at medium speed (30 mi/h)
 Approach Medium - Proceed but approach next signal ahead at medium speed (30 mi/h)
 Approach Limited - Proceed but approach next signal ahead at limited speed (45 mi/h)
 Limited Clear - Proceed but at limited speed (45 mi/h) within interlocking limits
 Medium Clear - Proceed but at medium speed (30 mi/h) within interlocking limits
 Slow Clear - Proceed but at slow speed (15 mi/h) within interlocking limits

There are some variations for different railroads but the range of speeds is similar.

The speed commands are displayed in a bewildering variety of signal aspects, some of which are shown below. For the full set, go to [NORAC Signal Rules](#).

"Approach"

It is worth adding a few notes here about the use of the word "approach" and how it is applied to US signals. Approach is the US term which would be known as "caution" in the UK. Approach Medium, Approach Limited and Advance Approach are all commonly used to describe certain types of signal commands in the US. There are basically three types of Approach signals: "Approach", "..... Approach" and just plain "Approach".

Approach tells you how fast you have to be going by the next signal only. Except in the case of Approach Slow, they say nothing about how fast you can go before the next signal. Also an "Approach" signal informs the driver that the next signal is not at Stop but also not at full Clear. For the interests of safety, trains with ATC are limited to 45 mph or less after passing any type of "Approach" signal but, going by the letter of the rules, the driver must only be doing the proscribed speed by the next signal. Furthermore, while trains with ATC are limited to 45 mph after passing both an Approach Medium or an Approach Limited, trains which pass an Approach Medium must slow to 30 mph by the end of the block, while trains which pass an Approach Limited can continue to travel at speeds up to 45 mph.

A "..... Approach" signal tells the engineer to reduce speed at once and then to expect a stop signal. In the case of Medium Approach the driver must begin to reduce to medium speed as soon as the Medium Approach signal becomes visible. This also serves as an informal overlap.

A simple Approach signal tells the driver to expect stop in one or two blocks and proscribes an immediate speed reduction. Advance Approach and Approach Medium or Limited are not always used interchangeably. Approach M/L makes use of signals with two or more "heads" but if you want to install three-block protection then it's easier to use Advance Approach.

Advance Approach proscribes a speed limit of 45 mph while Approach M/L doesn't. Approach M/L implies non-stopping signals ahead while Advance Approach implies the second signal is red. In the US, with huge freight trains the engineers really need plenty of time to prepare to stop and therefore they need signals that give them warning of a stop and others that warn them of a required slow-down.

"Approach" signals are most often used to indicate that a train will be taking some form of diverging route at an interlocking. Advance Approach signals warn of a stop in two blocks, Approach warns of a ABS (permissive) stop at the next signal and Medium Approach warns of an absolute stop at the next signal.

4.11.7. Types of Signals

As we have seen, there is a wide variety of signals in the US. Each R.R. originally had its own system but now, due to mergers, take-overs and split-ups, you can expect to find a mix of signals on any system. A display of the main types follows.

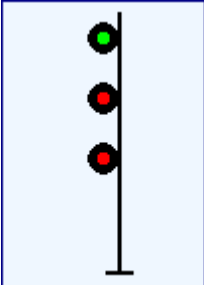

Searchlight signal common in the US and originally favoured by such railroads as the old AT&SF section of the BNSF. The lights are capable of displaying more than one colour. Some ABS examples have only one light to display green, yellow or red. This example is showing "clear" through an interlocking. Note that all US signals show speeds permitted, so that routes are not normally indicated by "feathers" (a row of white lights) above the signal. A route may be indicated by the vertical arrangement of aspects, so that Green over two reds indicates the main route whilst red over two greens means diverging route. Unlike the UK, all aspects are lit even if this means showing green and red together.

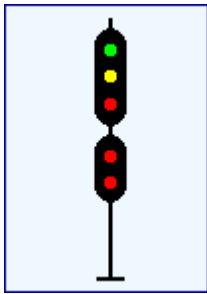

US colour light signal showing possible light displays. This type of signal is different from the AT&SF type shown above and is more akin to UK practice in that aspects not required are not shown. This diagram just shows the possible aspects. They are not all displayed together.

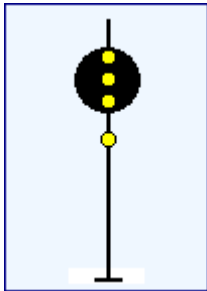

Position light signal beloved of the Pennsylvania R.R. The system emulated the old 3-position, upper quadrant semaphore system once common in North America. Three vertical lights means clear, diagonal lights means caution and horizontal lights means permissive stop and is usually accompanied by the yellow light below. The absolute stop lights are also horizontal but now usually red.

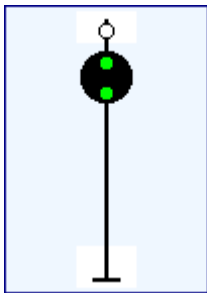

This is the colour position light system now used by Amtrak. It also emulates the semaphore signal system but with the addition of colour and only two lights for each position. The white light above the main display is extinguished when the two horizontal reds are shown if the stop is absolute.



US position light dwarf signal capable of showing "stop" (as seen) and "restricted speed". This signal bears a strong resemblance to the UK shunt signal.

Finally, a position light dwarf signal used by the old PRR. It looks very similar to the shunt signals used in the UK.

A selection of US signal types is available at [NORAC Signal Rules](#). From left to right in the diagrams displayed, the NORAC tables list the particular signal for the following systems: Pennsylvania R.R. Position Light (PRR PL), PRR PL w/ Red, PRR Hi-Dwarf, PRR Hi-Dwarf w/ Red, PRR Lo-Dwarf (X2), AMTRAK Colour Position Light) CPL, Colour Light (CL) 3 head, CL 2 head (X2), CL 1 head (X2), CL dwarf 2 head, CL dwarf 1 head, Baltimore & Ohio (B&O) CPL, B&O CPL Dwarf. Just look at the number of different ways of showing a driver (Rule 281) that the road ahead is clear and that he can proceed at normal speed.

4.11.8. The Imposition of ATS/ATC

The US uses automatic train stop (ATS) or automatic train control (ATC) on busy lines or where higher speeds are required. ATS is similar to the UK AWS while ATC is a form of automatic train protection (ATP), as it is called in the UK. In 1922, the US Interstate Commerce Commission (ICC) told railroads that it wanted them to install some sort of ATS or ATC on hi-speed lines as a safety precaution. The ICC made no regulations at first but it warned that it would do so in the future. Initially, several companies began to build ATS/ATC systems but then the depression of the 1930s, followed by WW2, slowed development. In 1951, the ICC made good on its word and mandated a nationwide 79 mph speed limit on any track not equipped with some sort of ATC/ATS. By this time many Americans had bought cars and given up on train travel so a number of railroad companies felt that ATS/ATC was not worth it and just accepted the speed limit but there were a few notable exceptions. These included the Pennsylvania R.R., which was a firm believer in safety systems.

The 79 mph speed limit is still in effect, although on some lines in the western US Amtrak has received permission to go up to 90 mph. On the east coast it is illegal for any non-CSS (Cab Signalling System) equipped train to run on CSS territory.

4.11.9. Types of ATS/ATC

ATS operates from track mounted inductors. At the first restrictive signal, the inductor acts to operate a warning noise for the driver who has a few seconds to acknowledge it and start braking the train or there is an automatic brake application. The system is sometimes used with cab signalling (called CSS), where the signal displays are shown in the cab. This requires a continuous [track to train transmission](#) system. On some lines equipped with cab signalling, there are no wayside signals.

ATC requires continuous track to train transmission since the speed of the train is being constantly monitored and cab signal displayed to the driver. If speed limits required by the signal displays are not adhered to, the ATC system will apply the brakes. ATC also operates over lines which are not equipped with wayside signals.

Here's how the system works: As a train passes signal A at the start of the block, a CSS coder at the end of the block sends the CSS code into a rail. The code consists of pulses of 100 Hz AC, 180 pulses for Clear, 120 for Approach Limited, 75 for Approach and 0 for Restricting or Stop.

The largest user of ATC with cab signal and with wayside signals was the Pennsylvania R.R. (PRR). The PRR had always been a leader in safety and was one of the first RRs with air brakes and knuckle couplers as standard. In the 1920's the PRR was busy electrifying and replacing old semaphore signals with yellow position light signals. They listened to the ICC and decided to install a Cab Signalling System on all main routes. This grew to include over 1100 route and 3000 track miles.

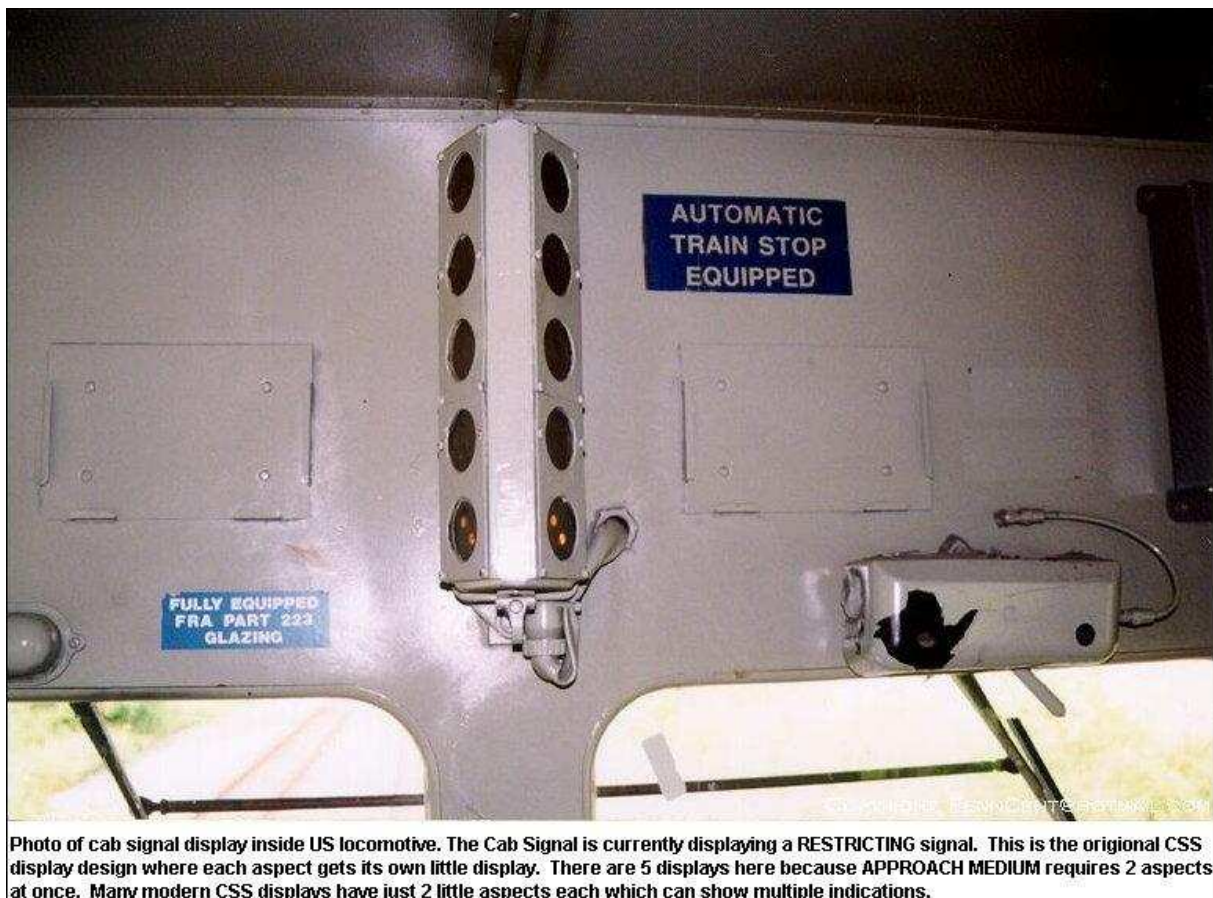

Here is a photo of an original US cab signalling display inside a locomotive. The Cab Signal in the picture is displaying a RESTRICTING signal. This is the original CSS display design where each aspect gets its own little display. There are five displays because APPROACH MEDIUM requires 2 aspects at once. Many modern CSS displays have just 2 little aspects each which can show multiple indications.

Sources: Mike Brotzman, and "The Railroad, What it is, What it Does" by John H Armstrong, 1993, Simmons Boardman Books Inc.

RAILWAY STATION DESIGN

5.1. INTRODUCTION

There was a time (in the UK at least) when the word "station" would only ever be taken to refer to a railway station. For some reason, nowadays people insist on referring to a station as a "train station", as if there was any other sort of station. Whatever it is called, the station can often be a neglected part of the railway scene but they are the usually first point of contact the passenger has with the system and they ought to be well designed and pleasing to look at. This page offers some insights into the design of stations and show some examples of how they have evolved.

5.2. BACKGROUND

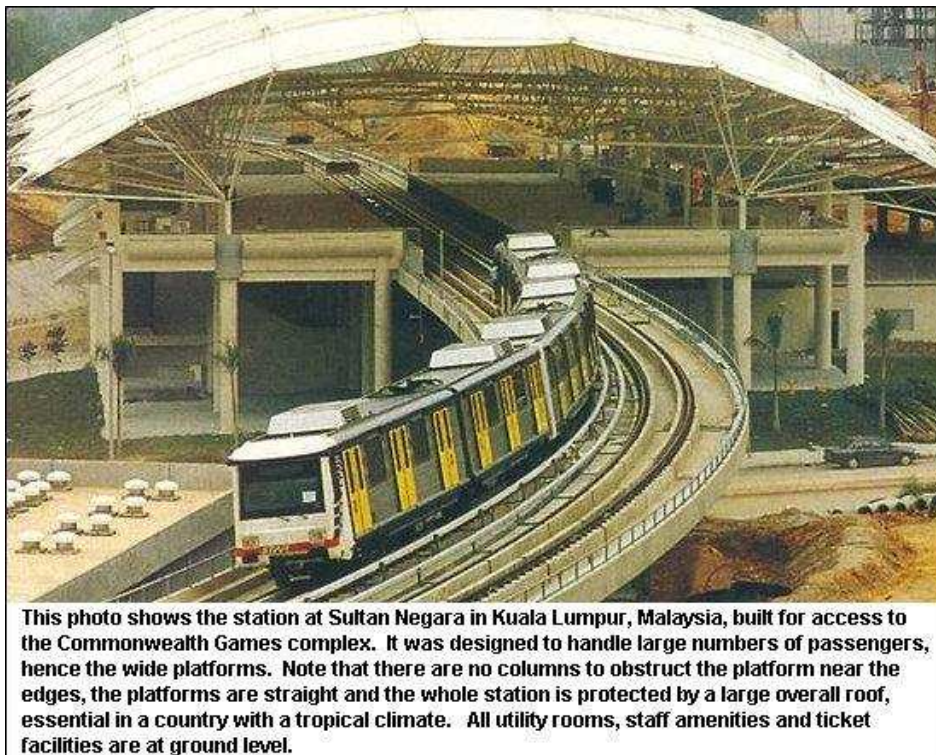

Stations are the places where trains stop to collect and deposit passengers. Since the station is the first point of contact most passengers have with the railway, it should be regarded as the "shop window" for the services provided. It should therefore be well designed, pleasing to the eye (photo left), comfortable and convenient for the passenger as well as efficient in layout and operation. Stations must be properly managed and maintained and must be operated safely.

5.3. STATION AND CROSSING SAFETY

There are two differing views about passenger safety at stations which have dictated station design for the last 150 years or more. For most of the world, it has been assumed that passengers (and other members of the public) will take care of their own

safety when walking on or near a railway. Because of this, it is not considered necessary to segregate passengers from trains. Passengers will look out for passing trains when crossing tracks and will take care not to leave luggage, children, cars or anything else which could damage or be damaged by a train. Station design has reflected this so that platforms were often not raised very much above rail level. Passengers were forced to climb up to trains, usually with the help of a plentiful staff and portable steps carried on vehicles. Passengers were free to wander across tracks, usually at walkways specially provided for them and any road vehicles which needed to cross the line. Railways were not fenced. Only at terminals and very busy stations was any attempt at segregation made.

In the UK, railways were always fenced and passengers and the public were invariably kept away from the tracks as far as possible. Platforms were built to a level which allowed a reasonable step up into a train without help and bridges or underground passages (called "subways" in the UK) were provided to allow people to cross the line unhindered by the movement of trains. The high platform also permitted quicker loading and inloading of trains.

In the US, the rise in the popularity and numbers of automobiles was matched by a decline in the use of railroads. The decline in the use of railroads meant there was also a decline in the awareness of the public of the nature of railroads or of the power and speed of trains and the distances they required to stop. The result has been an increase in the number of crossing accidents, where cars or trucks have been hit by trains. There have also been incidents where passengers have been struck by passing trains while crossing the tracks to reach a station exit.

5.4. PLATFORMS

The term platform is worth explaining. In the US, the position of a train in a station is referred to as the "track", as in "The train for San Diego is on Track 9". This is very logical as the raised portion of the ground next to the track is actually the platform and may well be used by passengers boarding a train on a track along the opposite edge of the platform. For this reason, the British way of referring to the "Train at Platform 4", referring to the platform "face", sometimes confuses foreign visitors, who see two trains, one on each side of the platform.

It is a feature of station design in the UK and railways designed to UK standards, that platforms are built to the height of the train floor, or close to it. This is now also adopted as standard on metro railways throughout the world. The rest of the world has generally had a train/station interface designed on the basis that the passengers step up into the train from a low level platform or even straight off the ground. To this end, passenger

vehicles were usually designed with end entrances, having the floor narrower than the rest of the car body so that a set of steps could be fitted to either side of the entrance gangway. However, high platforms are now seen in many countries around the world.

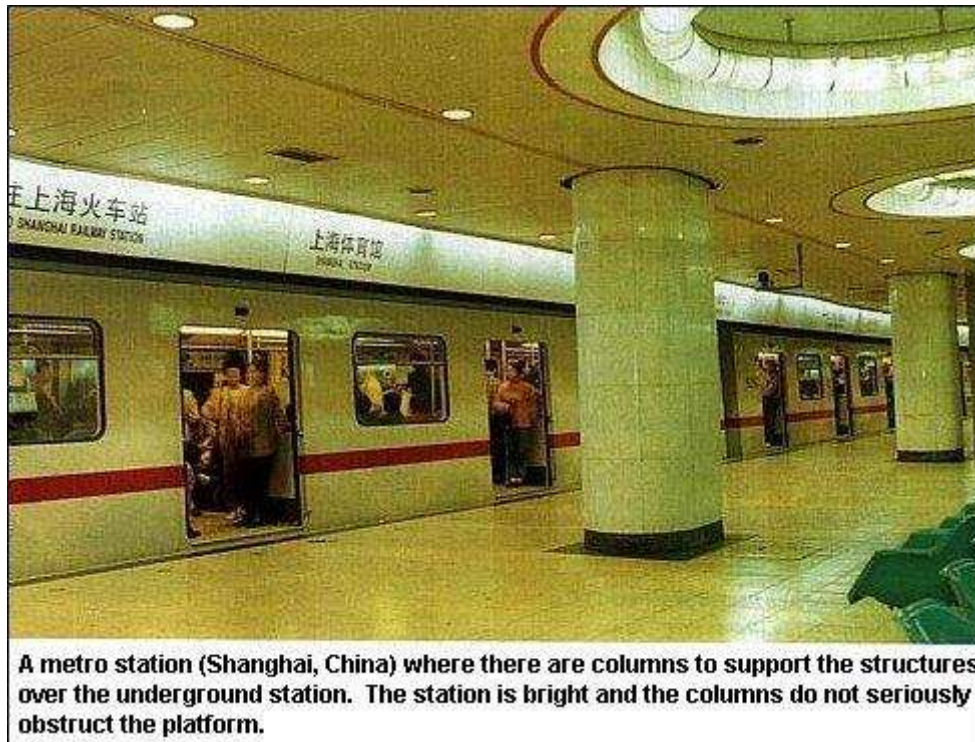

Platform width is also an important feature of station design. The width must be sufficient to accommodate the largest numbers of passengers expected but must not be wasteful of space - always at a premium for station areas in expensive land districts of a city. The platform should be designed to give free visual areas along its length so that passengers can read signs and staff can ensure safety when dispatching trains. Columns supporting structures (photo) can often seriously affect the operation of a station by reducing circulating areas and passenger flows at busy times. Platform edges should be straight to assist operations by allowing clear sight lines.

5.5. PLATFORM SCREENS AND DOORS

There has been a trend recently in modern metro systems towards incorporating glazed screens along platform edges (photo left). This is only possible where sliding powered doors are available on trains and where the location of these doors is always consistent, which is why screen doors do not appear on main line railways. There are a number of interesting points to remember when considering platform screen doors.



Platform screen doors or Platform edge doors are provided on the new Jubilee Line stations. The operation of the doors is synchronised with those on the train. The driver has to align the train with the doors to within ± 250 mm in order for the doors to open.

Platform screen doors (sometimes called "platform edge doors") were first introduced in St Petersburg (then Leningrad) on the metro to reduce heat losses on station platforms of underground stations. They were also fitted to the Lille VAL driverless system but, in this case, as a way of preventing passengers from getting onto the line where there were no drivers to stop the train. It too allowed a better degree of climate control within stations. Climate control was also the reason why doors were introduced for underground stations in Singapore when its metro system was started in 1989.

On most lines equipped with platform screen doors, the space between the sliding doors has emergency doors that can be pushed open onto the platform, so if the train stops out of position, there is still emergency access to the platform. There are also local station door controls provided at the platform ends, in case the automatic system fails.

London Underground has introduced doors on the underground platforms of its new Jubilee Line extension. These are more for safety reasons, since the suicide rate in London has gone as high as 150 attempts in some years. At somewhere around USD 1.5 million a platform, these doors are not cheap but the savings in passenger time due to prevention of delays quickly justifies the expense on a socio-economic level, even if you choose to ignore the savings in human life.

Against the provision of platform doors must be the cost of maintenance. Train doors account for more than half the rolling stock failures of most metro and suburban railways and the same sort of designs are used for platform doors. Any system which uses such

doors must ensure that adequate provision for maintenance is made and that any savings in heating or ventilation costs is not outweighed by failures.

In Lyons, France, the MAGGALY driverless automatic metro Line D has no platform screen doors. Instead the platform track areas are equipped with a network of electronic detector beams which trigger the train stop commands if a beam is broken. When it was first installed, there were so many false alarms that now, an alarm to the control centre allows the operating staff to observe the area through CCTV before confirming the stop command.

5.6. ENTRANCES AND EXITS



The entrance hall of Doncaster station, UK. The ticket office is immediately behind the camera position. The hall has a shop, a car rental office and public telephones. A train information display is mounted high on the wall and a TV screen duplicates the information below it. There is an information counter next to the shop, this being an additional service now often seen in larger stations. Flooring is designed to be easy to keep clean.

Station entrances and exits must be designed to allow for the numbers of passengers passing through them, both under normal and emergency conditions. Specific emergency exit requirements are outlined in many countries as part of safety legislation or to standards set down by the railways or other organisations. The codes in NFPA 130

(the US standard for their transit industry) are one such instance. These codes usually define the exit flows and the types of exits allowed for, e.g. the different rates for passages, stairways and escalators.

Whatever the codes define, the entrances to a station must be welcoming to the prospective passenger. Stations must also have sufficient entrances to cater for the different sides of the railway route but the number must also take into account the cost effectiveness of each entrance. The cost of staffing ticket offices can be very considerable and the numbers of ticket offices must be managed to suit the patronage offering.

Consideration must be paid to issues like which way doors open. On the Paris Metro in 1918, a crowd panicked near Bolivar station during an air raid on the city and 66 people were killed in a crush trying to get into the station for shelter. The obstacle that triggered the crush was a set of doors that only opened outwards normally the right direction for safety, but not when the crowd is trying to rush in! Subsequently it became Metro policy that all doors had to open both ways.

5.7. PASSENGER INFORMATION



Information systems (photo left) on stations are variously referred to as a Passenger Information System (sometimes referred to as PIS) or Passenger Information Display (PID). Professional railway staff often refer to them as Train Describers. Whatever it is called, there must be a reliable way of informing the passengers where the trains are going. Passenger information systems are essential for any railway. One of the most common complaints by passengers on railways is the lack of up to date and accurate information. When asking the staff for information, passengers expect an accurate and courteous response with the latest data. There is nothing worse than the "your guess is as good as mine" response when a member of staff is asked what is happening when a train is delayed or has not appeared on time. This means that staff must have access to the latest information and they must be trained to use it properly and to pass it on to passengers.

Information displays mounted in public areas must be visible in all weather conditions (noting that some electronic displays are very difficult to see in sunlight conditions) and be updated regularly with accurate information. There are two types of information - constant and instant. Constant information can be described as that which describes the services and fares available and which changes only a few times a year or less. This information can be displayed on posters and fixed notices. There also might be special offers which can be posted from time to time. Instant information is that which changes daily or minute by minute. This is better displayed electronically or mechanically - both systems can be seen around the world.

For instant systems, it can be assumed that passengers require to know:

- The time now
- The destination and expected time of arrival of the next train
- The stations served by this train
- Major connections requiring boarding of this train
- The position of their car - if travelling with a reserved place
- Where the train will stop - for variable length trains
- Other destinations served from this station and from which platform

A good example of passenger information displays can be seen on some Paris (France) RER stations. A large illuminated board is hung over the platform and all the stations served by the train approaching are shown by lamps lit next to the station name. The time now and the train length is also shown. Although the system is not now modern, it is very effective.

There are some information systems appearing with advertising in some form or other. This is a useful source of revenue or sponsorship but it must not be allowed to detract from the main aim of providing the passenger with train service information.

Some modernised lines are nowadays provided with bi-directional signalling. This allows trains to travel along either line at normal speeds and be fully under the control of fixed signals. This is a useful facility to have when engineering works have made one track unusable. Trains operating in either direction will then use the other track(s). For passenger information purposes, bi-directional signalling makes it necessary to have good and easily variable passenger information displays.

5.8. TOILETS

For a long time the provision of toilets on railway premises has been the subject of criticism and debate, both in the industry and amongst passengers. Passengers expect to be provided with facilities and complain loudly when they are not. On the other hand, public toilets are regularly abused and vandalised in many countries and railway administrations end up paying large amounts to maintain and repair them. They can also often be used for illegal activities, such as drug related offences, sexual activities and for robberies. Some railways, especially those in big cities, have, for many years, tried to close most of station toilets because of the cost of keeping them in a reasonable condition and because of the difficulties in policing them. The result has been an increase in the number of passengers relieving themselves in the public and sometimes in the prohibited areas of the railway, including cases where they have wandered onto the track and got themselves killed by passing trains. At the very least, these activities cause an odour and health risk nuisance.

Any railway operators responsible for stations will have to decide whether they are prepared to pay for the installation of toilets and, if they do so decide, they must be prepared for the management and maintenance of such facilities. Nowadays, it is considered good marketing to provide good restroom, baby changing and toilet facilities. They will not be cheap to provide and they will require regular inspections to ensure the safety and cleanliness of the premises. In spite of all the difficulties, toilets must be considered a requirement, if for no other reason than the public expect them. If they are installed, they must be designed to a high standard and then kept spotlessly clean throughout the day.

5.9. CONCESSIONS

Concessions on railway premises can be a lucrative source of income for a railway and the opportunity to provide for them should be taken wherever possible. The normal types of concessions are coffee shops, refreshment counters and small lunch rooms, plus pharmacies, dry cleaners, newspaper shops and flower shops. Some larger stations are able to provide space for so many shops that they are almost shopping malls in their own right. This is good for the railway, since it attracts customers and it provides a sense of community which would otherwise be lacking. There should, however, be limits as to what can be done and proper design in the first place and subsequent good estate management are both required to permit railway operations to continue unhindered and with safety.

Shops should not be allowed to sell dangerous goods and may be restricted in the sale of tobacco products if the railway has a no smoking policy. Some operators have excluded the sale of food within their property because they have a no eating/drinking policy.

Other railways regard food/beverage sales as an important part of the marketing strategy and positively encourage restaurants to take leases on stations. Food outlets must not be allowed to generate a rubbish or vermin problem.

At least, operators must prevent shops from allowing passages to become obstructed with sales equipment and they must ensure that they conform to the railway's safety requirements in cooking and similar activities. Leases for shops should detail all the exclusions required and lay out clearly the safety, evacuation and training requirements for shop staff.

5.10. STATION DESIGN

The design of stations has developed over the years as the use of railways has first expanded and latterly declined. A new form of station design has also evolved with the introduction of metros and high capacity urban railways. A number of different types of station design are shown below and the advantages and disadvantages of each are discussed.

On a railway which requires passengers to be in possession of a valid ticket or "authority to travel" whilst on the property, the station area is divided into an "unpaid area" and a "paid area", to denote the parts where passengers should be in possession of a valid ticket. Of course, there are now many railway operators who have "open stations", which allow passenger to wander at will without a ticket. In these circumstances, in addition to a ticket office or ticket selling machines, tickets can be purchased on the train.

5.11. SIDE PLATFORM STATION

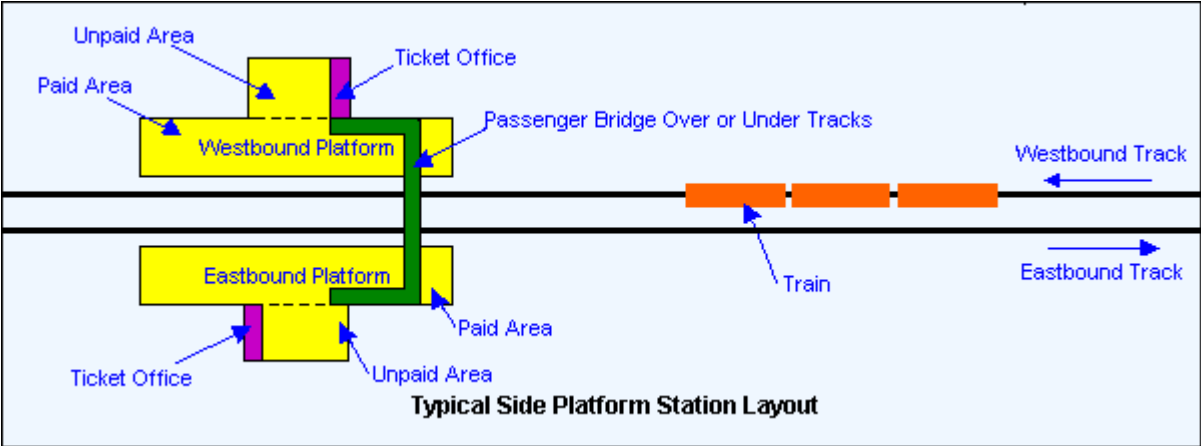

The basic station design used for a double track railway line has two platforms, one for each direction of travel. The series of examples in the following diagrams shows stations with right hand running as common in Europe and the Americas. Each platform has a ticket office and other passenger facilities such as toilets and perhaps a refreshment or other concession. Where there is a high frequency service or for designs with high

platforms, the two platforms are usually connected by a footbridge. In the case of a station where tickets are required to allow passengers to reach the platform, a "barrier" or, in the case of a metro with automatic fare collection, a "gate line", is provided to divide the "paid area" and "unpaid area".

This design allows equal access for passengers approaching from either side of the station but it does require the provision of two ticket offices and therefore staffing for both of them. Sometimes, stations with two ticket offices will man only one full time. The other will be manned as required at peak times.

5.12. ISLAND PLATFORM STATION

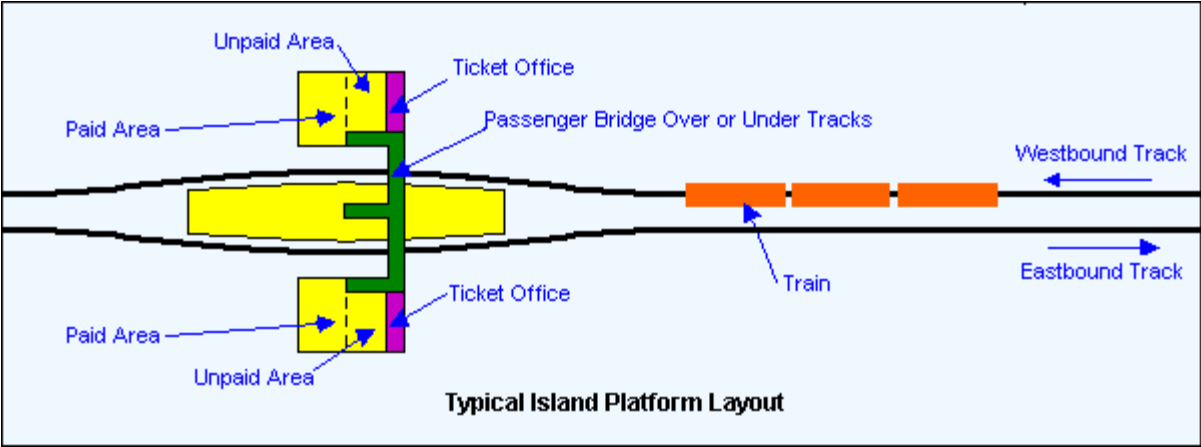

A cheaper form of station construction, at least for a railway at grade level, is the island platform. As its name suggests, this is a single platform serving two tracks passing on either side, effectively creating an island which can only be accessed by crossing a track. A bridge or underpass is usually provided. Island platforms are usually wider than single platforms used for side platform stations but they still require less area. In the example shown above, there are two ticket offices, but one can be provided if preferred. Island platforms on elevated railways do require additional construction of the viaduct structure (usually adding considerably to the costs) to accommodate the curves in the tracks needed to separate them on the approach to the platform.

5.13. ELEVATED STATION WITH SIDE PLATFORMS

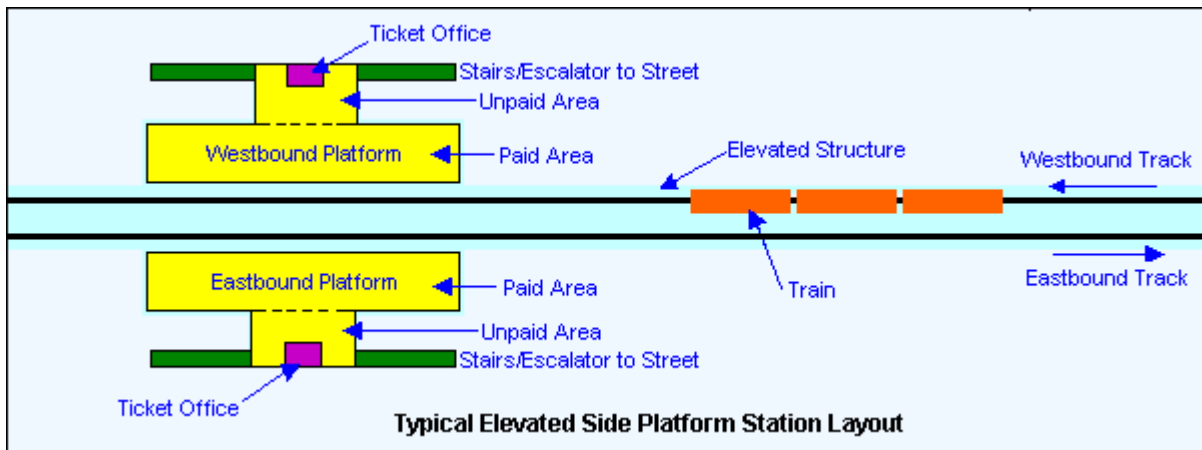

Elevated railways are still popular in cities, despite their history of noise creation and generally unfriendly environmental image. The poor image has been considerably reduced with modern techniques of sound reduction and the use of reinforced and pre-stressed concrete structures. They are considerably cheaper than underground railways (at least half the price, sometimes considerably less than that) and can be operated with reduced risk of safety and evacuation problems. Modern elevated railways have been built in such cities as Miami, Bangkok, Manila and Singapore.

5.14. ELEVATED STATION WITH TICKET HALL BELOW PLATFORMS

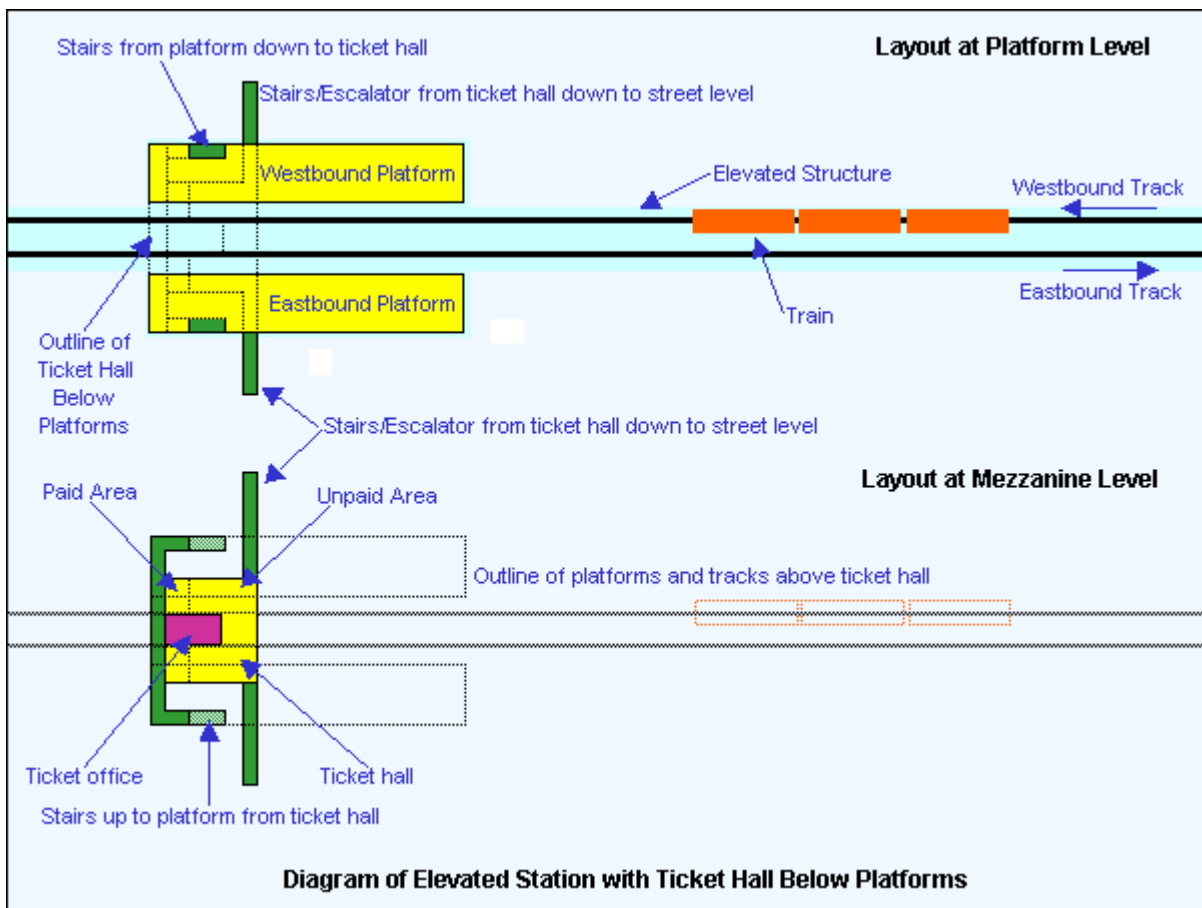

In the example illustrated immediately above, the ticket office and gate lines are below the platform level. This can be done to allow one ticket office to serve both platforms but it requires the space to be available below track level and this, in turn, requires enough height in the structure. Since many stations are built at road intersections, the location of the station structure might have to permit road traffic to pass beneath it and this requires an adequate height structure to be built. It is sometimes better to position the structure to one side of the road intersection to allow room below for the ticket office.

5.15. LIFTS AND ESCALATORS

Vertical transportation at stations in city environments and on urban railways is almost as important as the horizontal transportation provided by the trains. Any station not easily accessible on the surface and which requires stairs, will nowadays, require lifts for the disabled. Stations with a height difference between levels of more than 4 to 5 metres (13-18 feet) will probably need escalators as well certainly in the up direction. Escalators are expensive, so the number of passengers using the facility must be at a sufficient level to make them worthwhile. Both lifts and escalators are high cost maintenance items and need to be kept in good condition. They require mandatory regular safety inspections.

The siting of lifts and escalators is important. Passengers have to queue to board them so there must be space at the boarding point to accommodate a large number of people at busy times. Such areas must be kept free of obstructions and not be too close to platform edges. The number of stairways and escalators must be sufficient to allow a trainload of alighting passengers to clear a platform before the next trainload arrives. This may seem obvious, but it isn't always done. Most countries require an evacuation standard to be applied to the number and location of stairs and escalators. This enables the station to be cleared safely in the minimum time.

One other point to note. Escalators in the railway environment usually get a lot more use than those you see in department stores. A railway which buys a standard department store design escalator may find it will quickly wear out and will need constant repairs. A more robust design may be a better life cycle cost solution.

5.16. EXAMPLES OF GOOD STATION DESIGN FEATURES



A new underground station on the metro system of Santiago, Chile. A combination of striking architecture and subdued lighting combine to give a pleasing overall finish. The use of upper level galleries, visible to the left and right, is unusual but adds to the feeling of accessibility.

Architecture



An example of a wide station platform (Cairo Metro, Egypt) designed to accommodate large numbers of passengers boarding and alighting at the same time. Note that there are no supporting columns to limit circulation or visibility on the platform. There are a few seats for waiting passengers but these are arranged to prevent a person lying down on them. Vagrants sheltering in stations is a serious problem in some cities and has to be discouraged.

Platform Design



Madrid, Spain, offers an example of a light, airy station concourse with faregate lines dividing the "paid" and "unpaid" areas. The ticket office is located in the centre of the gate line so it can be used by passengers in both areas. The lightweight steel structure over the escalators in the foreground carries CCTV cameras and loudspeakers.

Concourse Design

INFRASTRUCTURE

6.1. INTRODUCTION

Track is the base upon which the railway runs. To give a train a good ride, the track alignment must be set to within a millimeter of the design. Track design and construction is part of a complex and multi-disciplinary engineering science involving earthworks, steelwork, timber and suspension systems the infrastructure of the railway. Many different systems exist throughout the world and there are many variations in their performance and maintenance. This page looks at the basics of infrastructure and track design and construction with drawings, photos and examples from around the world. Some information was contributed by Dan McNaughton, Simon Lowe and Mike Brotzman.

6.2. BACKGROUND

The track is a fundamental part of the railway infrastructure and represents the primary distinction between this form of land transportation and all others in that it provides a fixed guidance system. The track is the steering base for the train and has evolved from an ancient design of vehicle guidance with origins dating, some historians have suggested, from the Sumerian culture of 2000 BC. The modern railway version is based on the steel wheel running on a steel rail. Other forms of guided vehicle technology exist; rubber-tyred trains, magnetic levitation and guided busways, for example, but these are not dealt with here. There is a good description of the French-based rubber tyred train technology available at [The Rubber Tyred Metro](#).

6.3. BASIC CONSTRUCTION

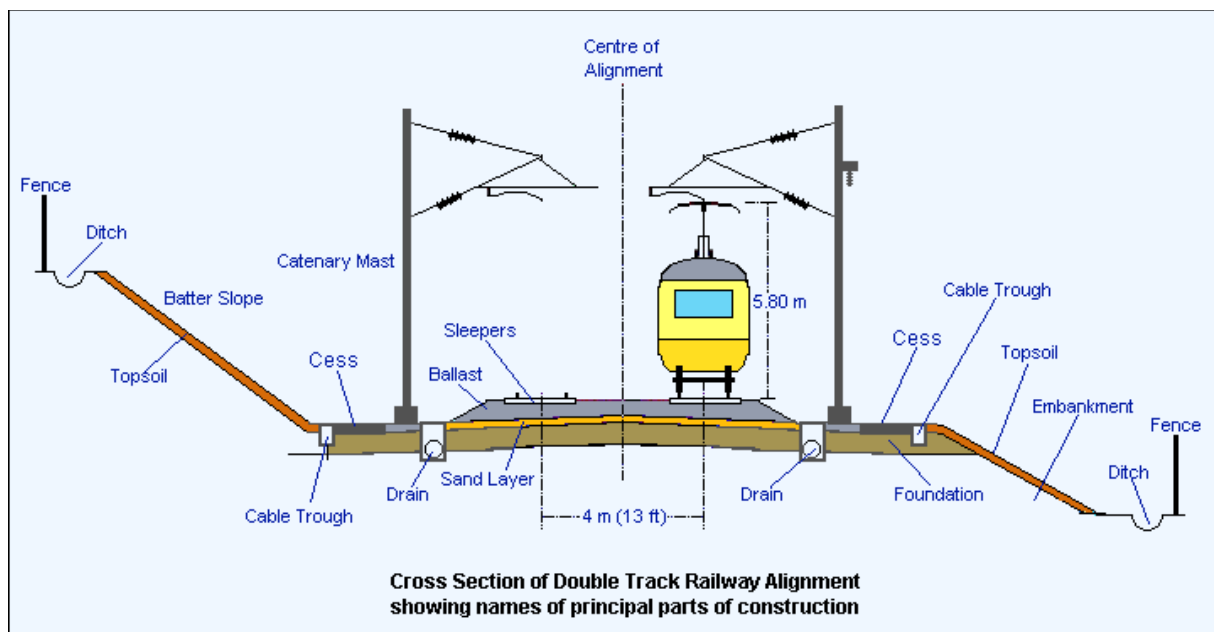

Track is the most obvious part of a railway route but there is a sub-structure supporting the track which is equally as important in ensuring a safe and comfortable ride for the train and its passengers or freight. The infrastructure diagram [here](#) shows the principal parts of an electrified, double-track line.

The total width across the two-track alignment will be about 15 m (50 ft) for a modern formation. The "cess" shown each side of the alignment is the area available for a walkway or refuge for staff working on the track.

6.4. THE SUB-STRUCTURE

This part of the road consists of three main elements; the formation, the sub-ballast and the ballast. The formation is the ground upon which the track will be laid. It can be the natural ground level or "grade" or it can be an embankment or cutting. It is important that the formation is made of the right materials and is properly compacted to carry the loads of passing trains.

The formation under the track has a "camber" rather like that seen on a roadway. This is to ensure ease of water run-off to the drains provided on each side of the line. The track itself is supported on "ballast", made up of stones usually granite or, in the US, basalt - below which is a layer of sand, which separates it from the formation. For new or renewed formations, the sand is normally laid over some sort of geotechnical screen or mesh to separate it from the foundation material below. In the past, asphalt or plastic sheeting has been used to prevent water seepage.

Catenary masts (if the line is electrified on the overhead system) are located outside the drains and, beyond them, there is a walkway area. This may just be a cleared path for staff to walk safely, avoiding passing trains or, on modernised routes, a properly constructed path. Next to this path will be a cable trough. These were originally concrete but are nowadays often made of plastic. Cables crossing the track are protected by a plastic tube, usually bright orange in the UK. Proper cable protection is essential to prevent damage by animals, track maintenance tools, weather and fire.

Usually, the edge of the railway property is outside the pathway or cable runs. If the line is built through an area requiring an embankment or cutting, the slopes will be carefully designed to ensure that the angle of slope will not take an excessive width of land and allow proper drainage but without risking an earth slip. The slope angle depends on the type of soil available, the exposure, the climate and the vegetation in the area. Drainage ditches are often added along the edges of cuttings and embankments. In the UK, fences are always provided along the boundary line of the railway to protect the public from wandering onto the track. Even so, there are a few accidents every year when

trespassers are killed or injured by trains or electric conductor rails. Many countries around the world don't fence their railways, assuming people will treat them like roads and look both ways before crossing. They don't.

6.5. BALLAST

Ballast is provided to give support, load transfer and drainage to the track and thereby keep water away from the rails and sleepers. Ballast must support the weight of the track and the considerable cyclic loading of passing trains. Individual loads on rails can be as high as 50 tonnes (55 US or short tons) and around 80 short tons on a heavy haul freight line. Ballast is made up of stones of granite or a similar material and should be rough in shape to improve the locking of stones. In this way they will better resist movement. Ballast stones with smooth edges do not work so well. Ballast will be laid to a depth of 9 to 12 inches (up to 300 mm on a high speed track). Ballast weighs about 1,600 to 1,800 kg/cu/m. See also [Ballasted vs Non-Ballasted Track](#) below.

6.6. TRACK

The usual track form consists of the two steel rails, secured on sleepers (or crossties, shortened to ties, in the US) so as to keep the rails at the correct distance apart (the gauge) and capable of supporting the weight of trains. There are various types of sleepers and methods of securing the rails to them. Sleepers are normally spaced at 650 mm (25 ins) to 760 mm (30 ins) intervals, depending on the particular railway's standard requirements.

6.7. SLEEPERS (TIES)

Traditionally, sleepers (known as ties in the US) are wooden. They can be softwood or hardwood. Most in the UK are softwood, although London Underground uses a hardwood called Jarrah wood. Sleepers are normally impregnated with preservative and, under good conditions, will last up to 25 years. They are easy to cut and drill and used to be cheap and plentiful. Nowadays, they are becoming more expensive and other types of

materials have appeared, notably concrete and steel.

Concrete is the most popular of the new types (left). Concrete sleepers are much heavier than wooden ones, so they resist movement better. They work well under most conditions but there are



Typical arrangement of concrete sleepers with flat bottomed rail and pandrol clips. Note how the sleepers are shaped to provide a degree of natural drainage.

some railways which have found that they do not perform well under the loads of heavy haul freight trains. They offer less flexibility and are alleged to crack more easily under heavy loads with stiff ballast. They also have the disadvantage that they cannot be cut to size for turnouts and special trackwork. A concrete sleeper can weigh up to 320 kg (700 lbs) compared with a wooden sleeper which weighs about 100 kg or 225 lbs. The spacing of concrete sleepers is about 25% greater than wooden sleepers. Typical concrete sleepers are shown in the photo below:

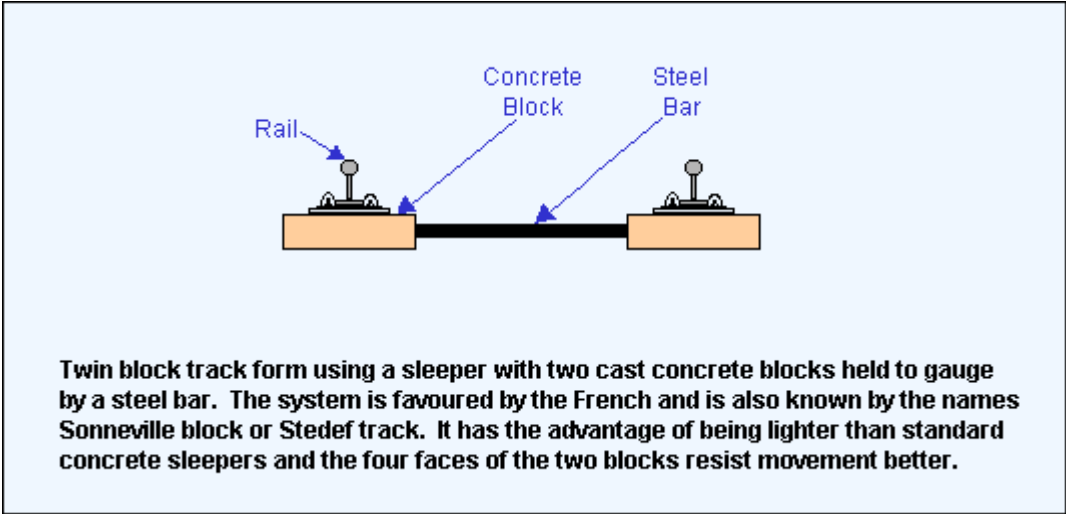

Another type of concrete sleeper is shown in this drawing. This is the twin-block sleeper.

The design consists of two concrete blocks joined by a steel bar. It is 30% lighter than a regular concrete sleeper, allowing it to be moved manually. It is popular in France (where it is called Stedef) and for some lighter track forms like those used for tramway systems. Here is an example in Sheffield.



It shows twin block and wooden sleepers in the same track. The sleepers shown in the above photo are supplemented with wooden sleepers at the crossover, because it is easier to cut the timber to the correct size. Sleepers at crossovers and turnouts vary in size according to their position in the layout.

Steel sleepers are also now used on more lightly used roads, but they are regarded as suitable only where speeds are 100 mi/h (160 km/h) or less.

In the US most ties are made of oak soaked in creosote, cost on average between \$22-\$29 each. It used to be up to \$35-\$40 per tie in the late 80's. They can last up to 20 years. Most Class 1 RR's will replace them after 5-10 years and then sell them as used. Concrete ties are \$42 dollars. They are popular in the western US and on passenger lines in the east. Recently, composite ties have come on the market. They are made of something like old tires and recycled plastic. They can be used and spiked like regular ties, cost about 50% less and save on trees.

6.8. RAIL

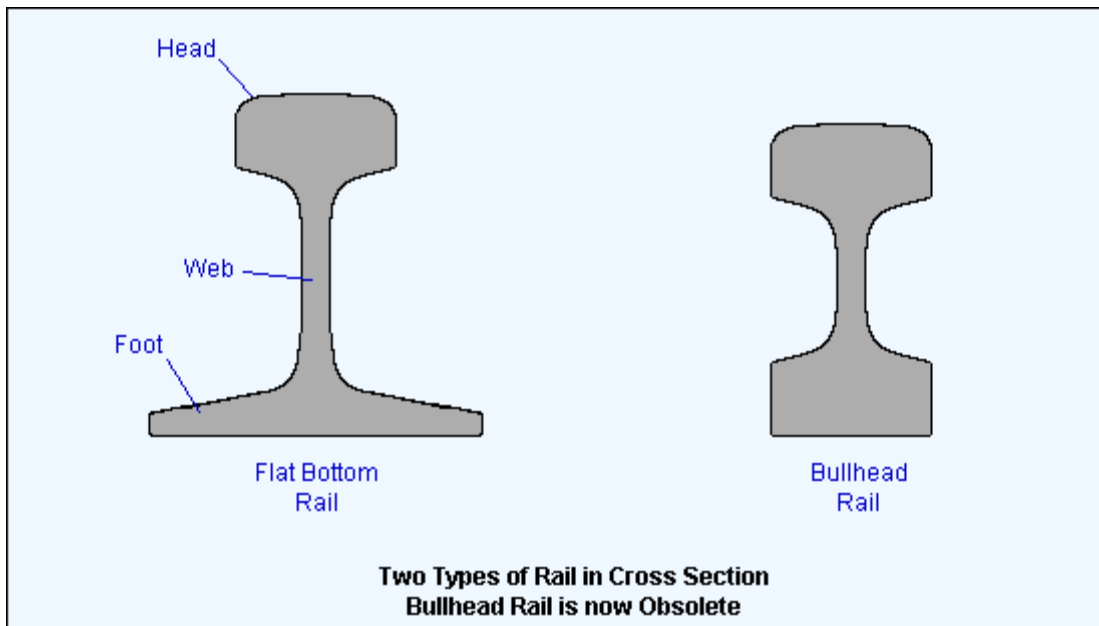

The standard form of rail used around the world is the "flat bottom" rail. It has a wide base or "foot" and narrower top or "head". The UK introduced a type of rail which was not used elsewhere apart from a few UK designed railways. This was known as "Bullhead" rail and is shown in comparison with the standard type in the diagram left.

Bullhead rail was originally designed with reuse in mind. It was intended that it would be turned over when the top had worn but this proved impossible because the underside also wore where it had been secured to the sleeper. Bullhead rail has to be mounted a special "chair" made of cast iron and secured by a "key" wedged between the rail web and the chair. The chairs are secured to the sleepers by "coach screws". The arrangement can be seen in the first photo below:

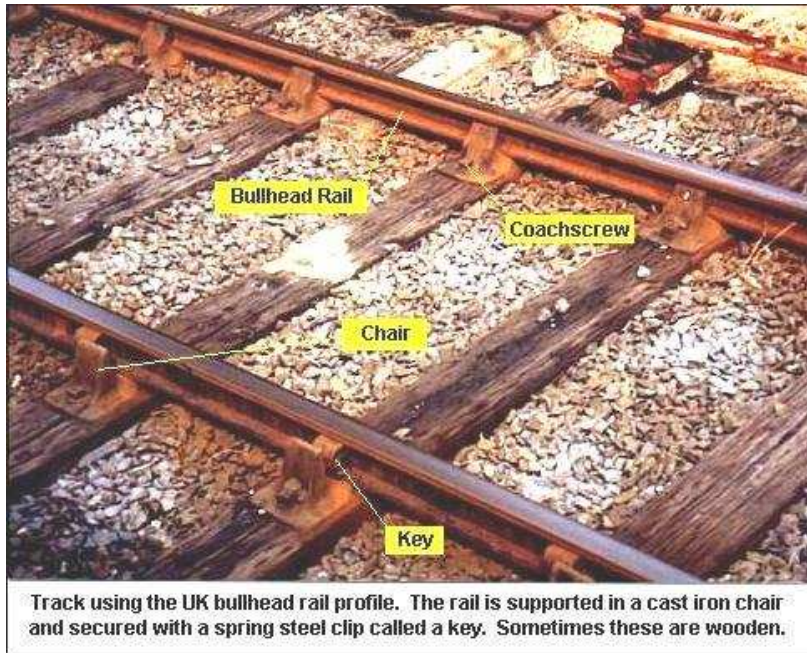

Bullhead Rails

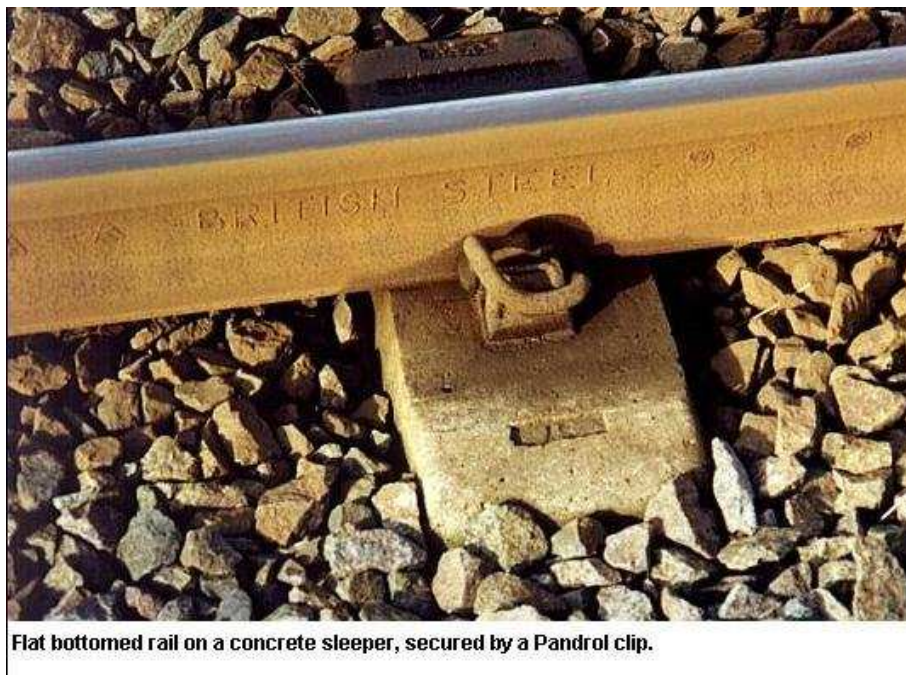

Flat Bottom Rails

The second photo above shows a flat bottom rail clipped to a baseplate under the rail. Flat bottom rails can also be "spiked" directly to the sleepers. A wide headed nail is driven into the sleeper on each side of the rail so that the foot of the rail is held by the heads of the spikes. Long stretches of track were laid in record times across the US in the pioneering days of railroad development using this method of securing rails to "ties". Nowadays, heavier loads and faster trains require more sophisticated systems.

Normally, the rail rests on a cast steel plate which is screwed or bolted to the sleeper. The rail is attached to the plate by a system of clips or clamps, depending on the design. The older UK standard design was an elastic spike with a sprung, curved top which secures the rail. There are a number of variations seen around the world. One of the most popular is the "Pandrol" clip seen above. A resilient pad will be provided between the rail and the base plate and around the securing clip, where required to provide insulation for the track circuits, if installed.

The infrastructure owning company in the UK (currently known as Network Rail), has adopted UIC60 rail (which weighs 60 kg/m or 125 lb/yd) as its standard for high speed lines. The present standard is equivalent to the UIC 54 rail, which weighs about 113 lbs/yd or 54 kg/m. Did you know, there are 2,400 sleepers (ties) in a mile of track?

In the US, rail weight varies from 80-90 lb/yd (pounds/yard) in small yards to 100-110 lb/yd on light duty track and between 130 and 141 lbs on heavy duty track. Rail of 141 lbs is the new main line standard. The Pennsylvania RR used a special 155 lb/yd rail, which was the heaviest ever rolled for mainline operations. Some of it is still in place with 8-bolt joints instead of the more usual 6-bolt joints. It is over an inch taller than comparable 141 pound rail. Highest price steel rail costs \$700 a ton (2000lbs). A 133 pound rail costs \$46.55 per yard (0.92 m.).

Older track is jointed. In the UK, about 35% of track is still jointed, although this is continuously falling as new rail is installed. Rails were normally laid in standard lengths bolted together by what are called fishplates in the UK or splices in the US. The joints allowed sufficient space for expansion as they were provided at 60 foot intervals in the UK and 39 foot in the US, allowing them to be carried in a standard 40 ft flat wagon. The joints were always staggered in the US whereas the UK placed them side by side. The result of the US staggered joints can be seen in the curious rolling motion of freight cars running on poorly maintained track. The reason for the staggering is that, in the US it was determined that after jointed rail has been in place for a time it starts to drop and creates a depression. When a wheel falls into the depression and begins to climb out again it exerts a force. If the two joints were in parallel this force would be much larger and the joints might snap. This is not considered a problem in the UK and Europe, probably because of the lighter axle loads.

Nowadays, rail is welded into long lengths, which can be up to several hundred metres long. Expansion is minimised by installing and securing the rails in tension. Provided the tension is adjusted to the correct level, equivalent to a suitable rail temperature level, expansion joints are not normally needed. Special joints to allow rail adjustment are provided at suitable locations as shown in the photo below:



Expansion joints are provided in running rails to allow for temperature changes. The additional rails in the centre of the track are bolted to the sleepers to prevent the sleepers being shifted by rail expansion.

Adjustment switches are also provided to protect turnouts and at locations where a change in the rail design or size occurs.

Rail tends to creep in the main direction of travel so "rail anchors" ("anti-creepers" in the US) are installed at intervals along the track. They are fitted under the rail against a base plate to act as a stop against movement.

6.9. RAIL WELDING

Modern trackwork uses long welded rail lengths to provide a better ride, reduce wear, reduce damage to trains and eliminate the noise associated with rail joints. Rail welding is a complex art (or science) depending on how you feel about it. There are two main types of welding used for rails: Thermit welding and Flash Butt welding.

6.10. GAUGE

The standard track gauge the distance between the two rails - is 4 ft. 8½ in or 1435 mm. but many other gauges, wider and narrower than this, are in use around the world. Gauge is often intentionally widened slightly on curved track. For a summary of a newsgroup discussion about the history of the standard railway gauge click [here](#). There is also some additional information on Track Gauges at the [Pacific Southwest Railroad Museum site](#).

6.11. MODERN TRACK FORMS

There are now a range of modern track forms using a concrete base. They are generally used in special locations such as tunnels or bridges where a rigid base is required to ensure track stability in relation to the surrounding structures. This type of track, usually called "slab track" or "non-ballasted" track, often appears as shown in the diagram below:

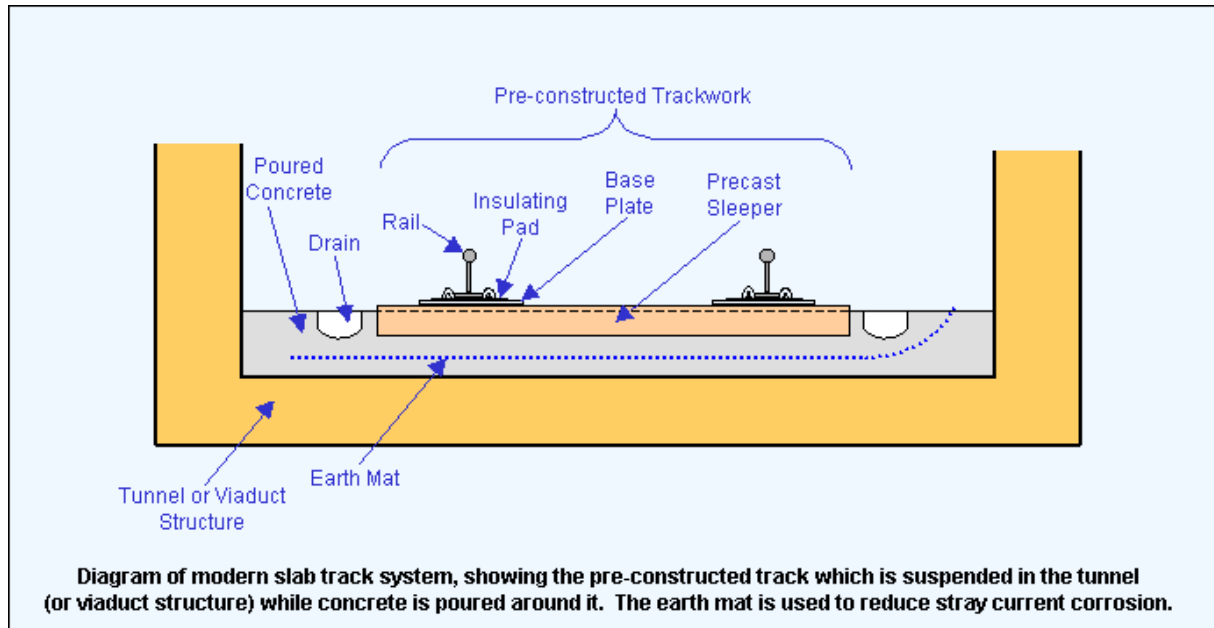

The earth mat is a steel mesh screen provided on electrified railways to try to keep stray return currents from connecting to utilities pipes and nearby steel structures. Earthing must be strictly controlled otherwise serious and expensive problems will occur, made more serious and expensive because they involve other people's property.

Some slab track systems have the sleepers resting on rubber or similar pads so that they become "floating slab track". Floating track is used as a way of reducing vibration. Hong Kong Mass Transit Railway is fond of it, since its lines run through very densely populated areas.

6.12. BALLASTED VS NON-BALLASTED TRACK

The basic argument for different track designs will be based on the bottom line cost; cost of installation and cost of maintenance. There are however, other issues such as environment noise, dust and vibration or engineering issues such as space, location, climate and the type of service intended for the track.

There are a wide variety of track forms and systems incorporating some form of concrete base or support which doesn't need ballast. Almost all of these require less depth of construction than ballasted track. However, the accuracy of installation must be higher

than that needed for ballasted track. Slab track will not be adjusted after installation but ballast can be packed to align track as required.

The ability of ballast to allow track realignment is one of its most serious weaknesses. The lateral movement caused by passing trains on curved track is one of the major causes of maintenance costs added to which is the crushing caused by axle weight and damage due to weather and water. Ballast damage leads to tracks "pumping" as a train passes and, eventually, rail or sleeper damage will occur, to say nothing of the reduced comfort inside the train and the additional wear on rolling stock. Apart from regular repacking or "tamping", ballast will have to be cleaned or replaced every few years.

Another aspect to the ballasted track design, is the dust which is caused during installation and as it wears or gets crushed. It does however, offer a useful sound deadening quality.

Fixed track formations using slab track or a concrete base of some sort do not suffer from such problems. However, the installation of slab track is reported to cost about 20% more than ballasted track. To balance this cost, the maintenance costs have been quoted as reduced by 3 to 5 times that of ballasted track on a high speed line in Japan.

If low levels of use are foreseen, or if low capital cost is a more important requirement, ballasted track would be the choice. For a heavily used railway, particularly one in a structurally restricted area like a tunnel or viaduct, non-ballasted track must be the best option on grounds of low maintenance cost and reduced space requirements. However, care must be taken during design and installation to ensure the best out of the system.

6.13. STRUCTURES

To ensure that the path required for the passage of trains is kept clear along the route of a railway, a "structure gauge" is imposed. This has the effect of forming a limit of building inside which no structures may intrude. The limit includes not only things like walls, bridges and columns but also pipes, cables, brackets and signal posts. The "structure gauge" will vary with the curvature of the line and the maximum speeds allowed along the section in question.

Although the civil engineer is prevented from allowing his structure to intrude into the train path, the rolling stock engineer also has limits imposed on the space his train may occupy. This space is referred to as the "kinematic envelope". This area designates the limits the train can move laterally and vertically along the route. As for the structure gauge, the kinematic envelope will be affected by speed and features of train design such as the bogie suspension and special systems it may have like tilting.

6.14. GAUGING

The line of route has to be checked from time to time to ensure that the structures are not interfering with the gauge. A line is always gauged when a new type of rolling stock is to be introduced. It is important to see that the small variations in track position, platform edge, cable duct location and signal equipment hasn't been allowed to creep inwards during maintenance and renewal programmes.

Gauging used to be done by hand locally (and still is from time to time in special circumstances) but nowadays, it is mostly done with a special train. The train used consist of a special car with a wooden frame built almost to the gauge limits. The edges of the frame were fitted with lead fingers so that, if they hit anything as the train moved along, they would bend to indicate the location and depth of intrusion.

Modern gauging trains are fitted with optical or laser equipment. The optical system uses lights to spread beams of light out from the train as it runs along the line. Suitably mounted cameras record the breaks in the light beams to provide the gauging information. The train can run at up to 50 mi/h (80 km/h) but, of course, the runs have to be done at night. Laser beams are also used but, as they rotate round the train and form a "spiral" of light, the method suffers from gaps which can allow intrusions to be missed.

6.15. MONUMENTS AND DATUM PLATES

Along the line of route various locations are marked by a fixed post in the track or a plate on a nearby structure to indicate the correct level or position of the track. These are called monuments or datum plates. Measurements are taken from these to confirm the correct position of the track.

6.16. CURVES

Curves in the track are almost a science on their own. Careful calculations are required to ensure that curves are designed and maintained properly and that train speeds are allowed to reach a reasonable level without causing too much lateral stress on the track or inducing a derailment. There are both vertical curves and horizontal curves. There is also a section of track on either side of a curve known as the transition, where the track is changing from straight to a curve or from a curve of one radius to one of another radius.

6.17. CANT

Cant is the name used to describe the cross level angle of track on a curve, which is used to compensate for lateral forces generated by the train as it passes through the curve. In effect, the sleepers are laid at an angle so that the outer rail on the curve is at a higher level than the inner rail. In the US, it is known as superelevation.

Of course, there will usually be trains of different types, permitted speeds at different levels, which travel the same curve. Also, there will be occasions when trains stop on the curve. This means that the degree of cant has to be fixed at a compromise figure to allow the safety of stopped trains and the best speeds for all the trains using the curve.

In practice, faster trains are allowed to travel round the curve at a speed greater than the equilibrium level offered by the cant setting. Passengers will therefore feel a lateral acceleration similar to what they would feel if there was no cant and the train was travelling at a lower speed round the curve. The difference between the equilibrium cant required by the higher speed and the actual cant is known as the cant deficiency.

Cant is measured either in degrees or in linear dimensions. On standard gauge track (1435 mm or 4ft. 8½ins.) 150 mm or 6 ins. of cant is equal to 6 degrees. This is the normal maximum in the UK. The maximum amount of cant deficiency allowed is 110 mm (4½ ins.).

6.18. TURNOUTS

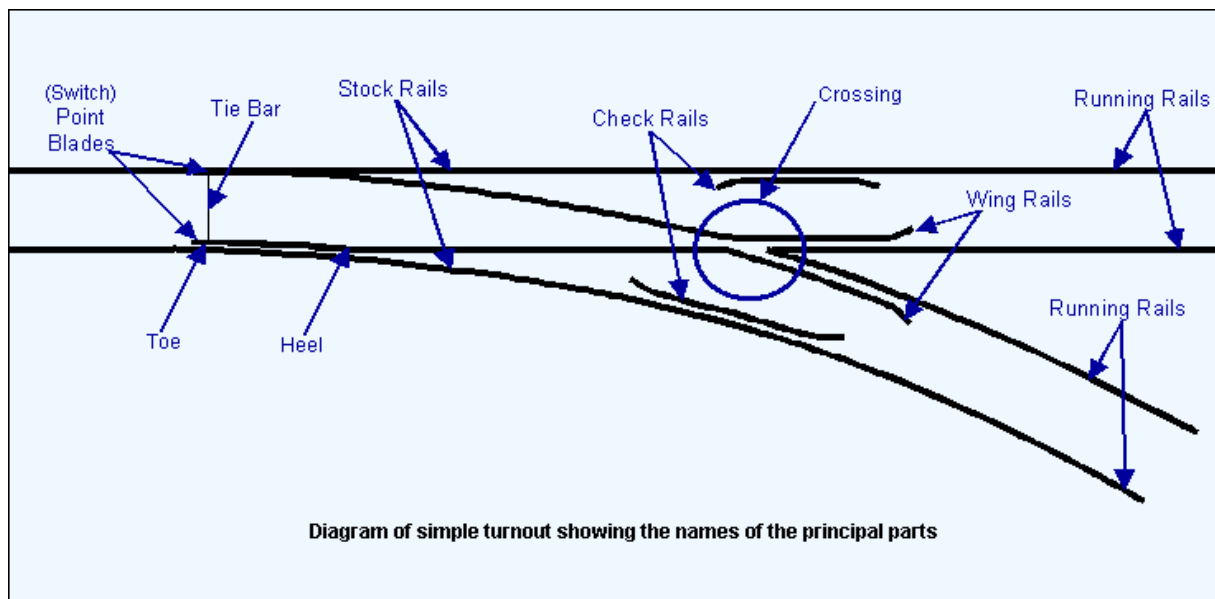

I have used the word "turnout" to describe the junctions in trackwork where lines diverge or converge so as to avoid "points" (UK) or "switches" (US), both of which terms can be

confusing. In the railway "trade", turnouts are referred to as "switch and crossing work". A turnout consists of a number of parts as follows:

The moving part of the turnout is the switch "blade" or "point", one for each route. The two blades are fixed to each other by a tie bar to ensure that when one is against its stock rail, the other is fully clear and will provide room for the wheel flange to pass through cleanly. Either side of the crossing area, wing and check rails are provided to assist the guidance of the wheelsets through the crossing.

6.19. CROSSINGS

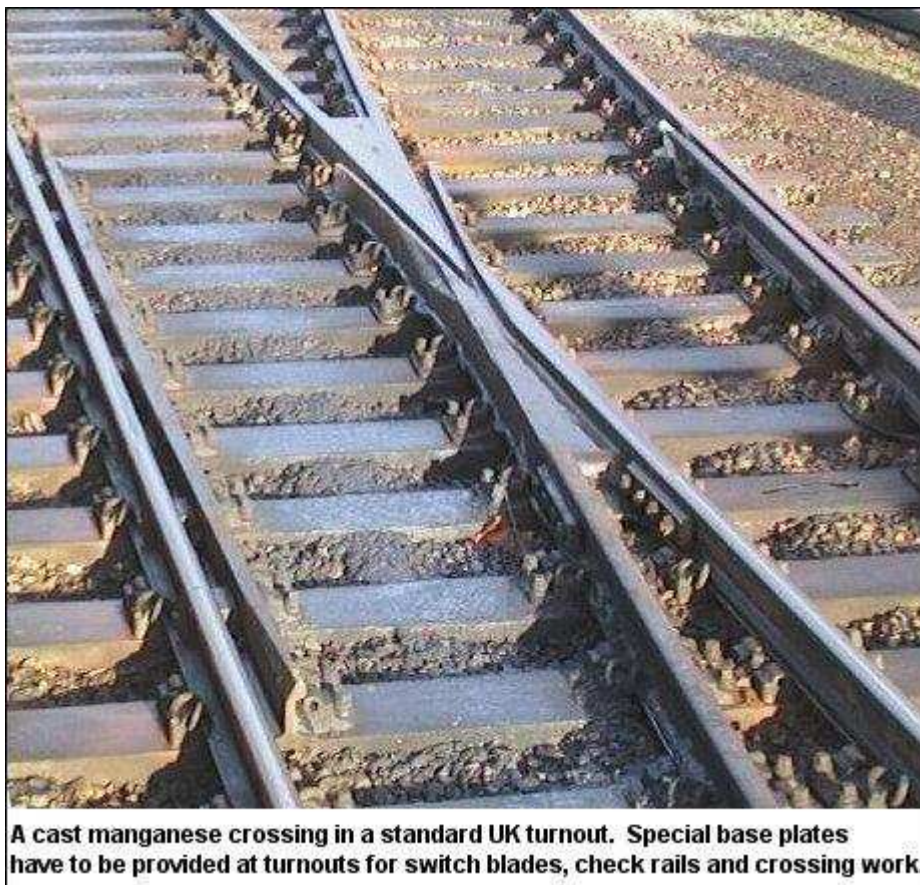

The crossing can be cast or fabricated. Rails are usually made of steel with a large iron content but a little manganese is added to crossings and some heavily used rails to increase resistance to wear. Below is a photo of an example of a cast manganese crossing. A crossing is also sometimes referred to as a "frog".

6.20. TYPES OF TURNOUTS

There are a number of standard layouts or types of turnout, as shown in the following diagrams.

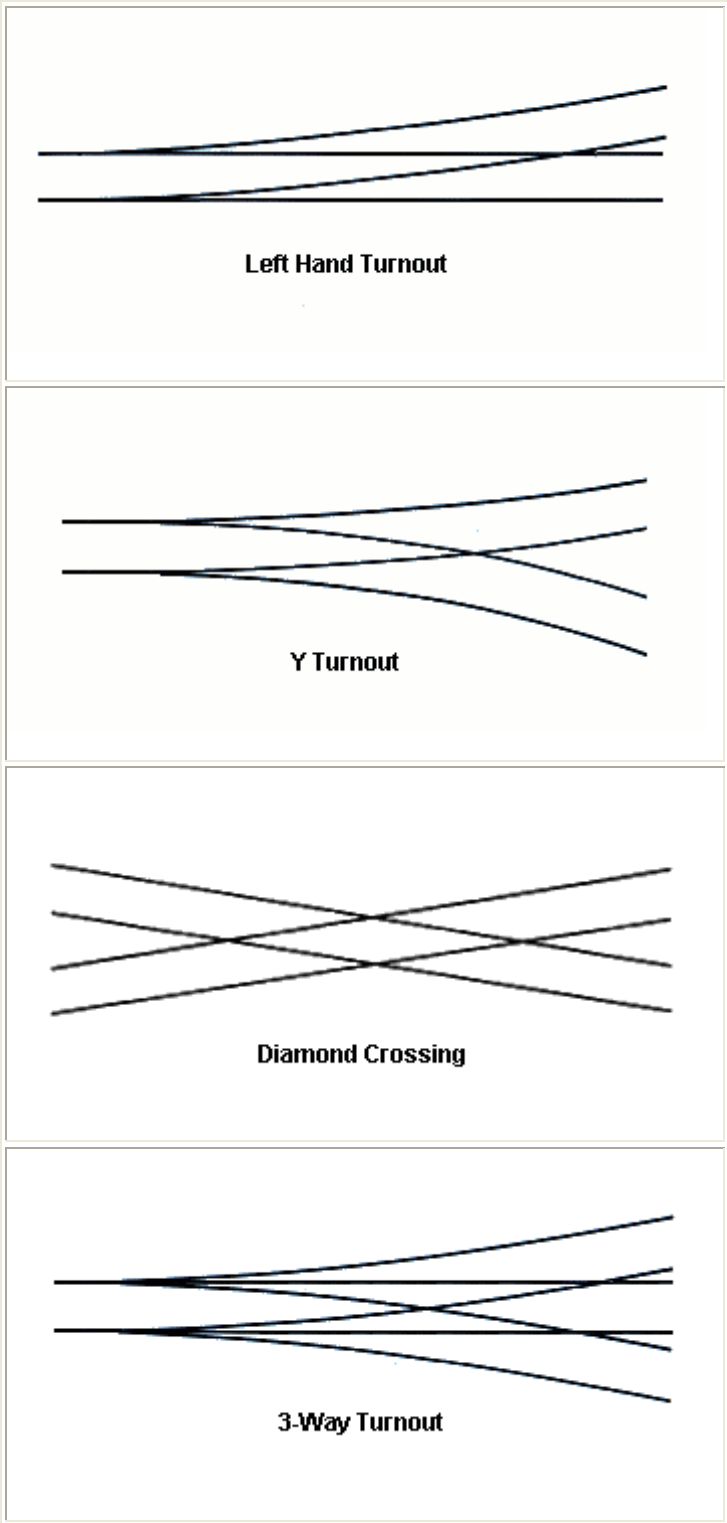

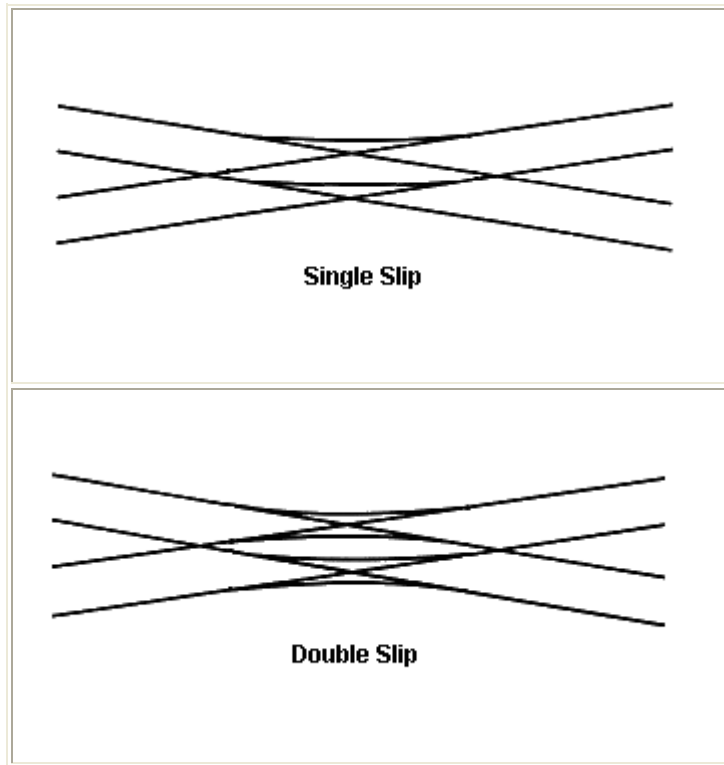

These can be found anywhere but the trend is to make layouts as simple as possible in order to reduce installation and maintenance costs. The more complex layouts are usually only used where space is limited.

6.21. EXAMPLES OF TURNOUTS

The uses of turnouts are wide ranging and cover many variations. A few examples are offered below to show the diversity available.

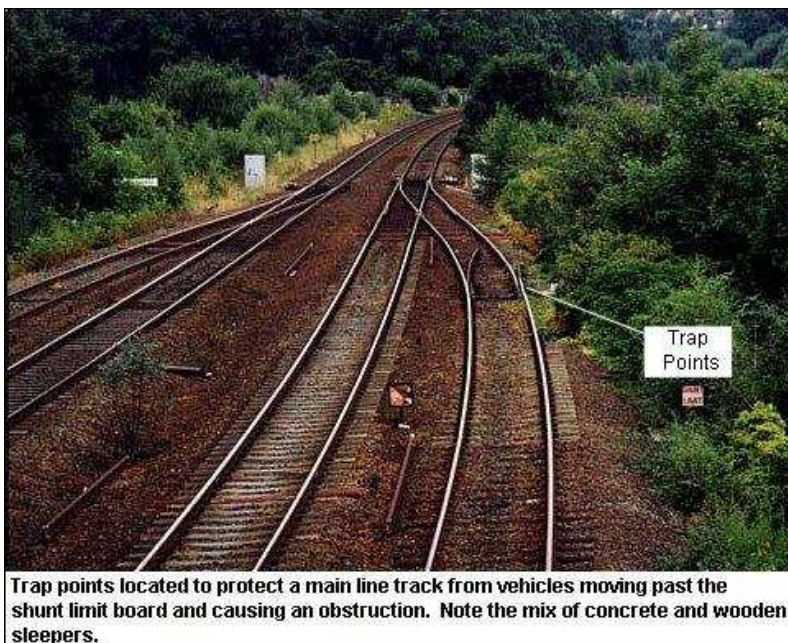

Trap Points are provided at the end of a siding or loop line to protect the main line from a train or vehicles which accidentally pass beyond the limits of the siding. They are normally unpowered trailing points, i.e. they allow a train to pass safely through one direction but will cause the train to be derailed if it passes in the wrong direction.

Similar points called Catch Points were often provided at the lower end of a gradient to derail runaway vehicles. In the photo shown here, the points are provided at the limit of authorised shunting.

a-High Speed Switch



High Speed trains require high speed turnouts. In Japan, the so-called "bullet train" or "Shinkansen" has special routes and trackwork. Turnouts are designed for 160 km/h (100 mi/h) operation. In the example shown here, there are seven point motors to operate the very long and heavy switch blade. Similar turnouts are provided for the TGV high speed lines in France.

b-Switched Crossing

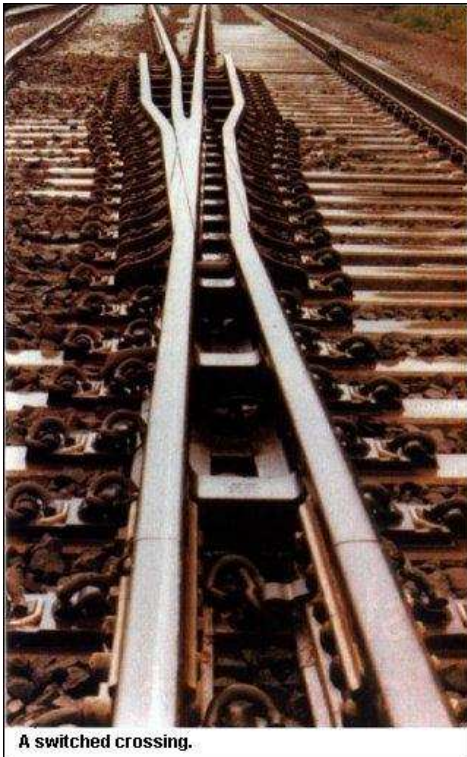

A switched crossing.

A switched crossing (sometimes referred to as a swing nose crossing or moveable frog) will normally be provided for turnouts with a very acute angle. The crossing will have a powered element which will be set for the required route at the same time as the switch blade is set.



A point machine located adjacent to the switch blades it operates. Most point machines are electrically operated but London Underground has a large number of air operated machines.

The blades of a turnout are normally moved remotely using an electrically operated point machine. The machine contains the contacts which confirm the points are moved and locked in the correct position for the route set. Point machines are normally located to one side of the track but a new generation of machines is now appearing where the mechanism is contained in a sleeper fitting between the rails.

c-US Switch Machine



US turnout showing the electro-pneumatic motor to operate the switch blades and the point heater tube alongside the stock rail. Heaters are invaluable in cold weather conditions and are widely used. Turnout motors are usually electric but electro-pneumatic motors are seen in the US and are standard equipment for London Underground.

In some parts of the US, electro-pneumatic point machines are used. They are referred to as switch motors. The London Underground also used e.p. motors. They require an air main to be laid alongside the track and compressors to supply the air. They can also cause problems with condensation due to climatic changes. This photo also shows a heater used to keep the turnout blades free of ice and snow during bad weather.

Sources:

Railway Age; Modern Railways; International Railway Journal; Railway Gazette International; Mass Transit; Trains Magazine.

GLOSSARY

7.1. TRAIN BRAKING GLOSSARY

Have you heard the story of the browbeaten duck? He could fly as fast as the other ducks but he couldn't stop as quickly. To a train driver, the brakes are the most important part of the train but not many people outside the industry understand how they work. With that in mind, this page provides a simple glossary of brake equipment.

Air Brake

This is the most common type of train brake. It uses compressed air to apply the brake block (or pad) to the wheel and to control the operation of the brake along the train. The compressed air is supplied by a motor driven compressor on the locomotive or train.

The brake control is actuated from a "driver's brake valve". This valve is used to feed air to the brake pipe or to allow air to escape from the brake pipe. A fall in [brake pipe](#) air pressure causes a brake application on each vehicle whilst a restoration of pressure causes the brake to release.

A [distributor](#) (or "triple valve" as it was always called and sometimes still is) on each vehicle monitors the pressure in the brake pipe. When brake pipe pressure falls, the distributor allows air from an [auxiliary reservoir](#) on the vehicle to pass to the brake cylinders to apply the brake. When brake pipe pressure rises, the distributor releases the air from the brake cylinder and recharges the auxiliary reservoir for the next application. The release of air from the brake cylinder allows the block to be released from the wheel by a spring.

Air Dryer

A device provided on trains (usually next to the compressor) to automatically remove moisture from compressed air produced by the [compressor](#). If moisture is allowed to pass into pipework, it collects in valves and systems, reducing efficiency and causing rust. Some older systems collected so much moisture that up to 20 gallons of water could be drained from a train. To remove it, an old oil drum was wheeled under the train and the [main reservoirs](#) drained directly into it.

In days gone by, a main air reservoir under a vehicle could collect so much condensate (water) that a sharp frost could cause it to freeze and expand sufficiently to split the tank. See more under the [Compressor](#) description.

Analogue E-P Brake Control

A form of [electro-pneumatic brake](#), normally restricted to multiple unit trains, which uses a single train wire to control the braking on each vehicle. The brake commands consist of pulses of electricity applied to the wire, a continuous signal denoting brake release and a loss of signal an emergency brake application. The brake control valve on each vehicle detects the length of the pulses and provides air input to the brake cylinders accordingly. The air supply is from the main reservoir pipe.

The analogue e-p brake system requires no [brake pipe](#) and the brake commands can be generated by a driver's brake controller or an automatic train driving system (ATO). It is also known as PWM (pulse width modulation) control or P-wire for short.

Angle Cock

A pneumatic isolating cock used on railway vehicles to shut off and/or drain air pipes ([hoses](#)) between vehicles. They are normally positioned at vehicle ends to allow the inter-connecting hoses to be isolated and, if provided with [bleed holes](#), drained of air before being uncoupled. See also [isolation](#).

Automatic Brake

The term is synonymous with [continuous brake](#).

Auxiliary Reservoir

An air tank provided on each vehicle of a train equipped with [air brakes](#) to supply air for brake applications. More recently known as the brake reservoir.

Bar

Metric measurement of pressure equal to 14.5 pounds per square inch.

Bleed Hole

A small hole provided in the angle cocks of main reservoir hoses which opens when the angle cock is closed. This has the effect of draining the air from the hose before it is uncoupled. Bleed holes are not provided on brake pipe angle cocks.

Brake Beam

A transverse member of the [brake rigging](#) which distributes the force from the [brake cylinder](#) to the [brake blocks](#) on either side of the [wheelset](#).

Brake Blending

A system, used on modern, dynamically braked [EMU](#) vehicles and some locomotives, to ensure that air and dynamic braking acts in co-ordination. An electronic signal from the electric (dynamic) brake indicating the brake effort achieved is compared with the brake effort demanded by the driver or an automatic control system and will then call up additional braking from the air brake system if required. See also [dynamic braking](#).

A typical set-up on a car will comprise a brake control unit which contains electronic controls and electro-pneumatic valves. Various inputs are processed in the brake control unit which then generates electronic or pneumatic outputs as necessary.

Brake Demand: When a brake demand is requested by the driver (or the automatic driving control on an [ATO](#) equipped train) it is transmitted along a train wire to the brake control unit on each car. The signal can be digital or analogue providing a message either in steps or infinitely variable. The demand is then matched to a load compensation signal provided by the car suspension system. The greater the weight, the greater the brake demanded.

The brake effort demand is now converted into air pressure signal and the brake is applied by sending air into the brake cylinders until it matches the signal. At the same time, a matching demand is sent to the dynamic brake controller and the traction control system will initiate dynamic braking. The system will send a "dynamic brake effort achieved" signal to the brake controller which will subtract it from the air brake demand signal and so reduce the brake cylinder pressure accordingly.

Dynamic Brake: In an ideal world, the dynamic brake will be used as much as possible to reduce wear on brake pads (or blocks) and there are often circumstances when the dynamic brake will provide all the braking required. However, it is normal to leave a little air in the brake cylinders in case the dynamic brake switches off suddenly. This reduces the time taken for air pressure to restore to the demand level when dynamic braking is lost.

Smoothing: Another feature of modern brake control is the "inshot". This is a small amount of air injected into the brake cylinders immediately brake is called for so that the build-up time is reduced. Braking systems are also "jerk limited"; smoothed out as they are built-up so that the passengers don't feel the cars snatch as the brake is applied. This is particularly important in the case of dynamic brakes which, if not jerk limited, have a tendency to apply sharply if the train is at speed.

Fade: Once the brake is applied, the dynamic portion will have a tendency to fade as the speed, and thus the current generated by the motors, reduces. Some systems have a pre-fade control; a signal sent by the traction controller to indicate the brake is about to start fading. This gives a smoother changeover into air braking.

Trailer Cars: Most types of EMU comprise a mixture of motor cars and trailers cars. As trailer cars have no motors, they do not have their own dynamic braking. They can, however, use dynamic braking on motor cars in their braking effort if that is available. In the case of a two-car pair, for dynamic demand, the motor car brake control unit will add the trailer car demand to the motor car demand. The resulting dynamic brake achieved may be sufficient to match all of the motor car demand and have some extra for the trailer. In this case, the motor car brake control unit sends a message to the trailer car to say how much of the trailer car's demand has been fulfilled by the dynamic brake. The trailer's air brake pressure can be reduced accordingly.

There will be some limit on the total dynamic brake possible because of adhesion limits and this will be incorporated into the brake control calculations. If the dynamic brake is reduced for any reason, the trailer car air brakes will be reapplied first followed by the motor car brakes.

Brake Block

Material applied to the tread of the wheel tyre to effect braking on vehicles equipped with the tread brake system. The block is hung from a lever or levers suspended between the brake cylinder and the wheel. Cast iron was, and still is widely used but wood has also been used on some systems (e.g. Paris metro) and modern railways now use any of a wide variety of composition materials whose exact details remain the closely guarded secret of the suppliers. See also [Brake Pad](#).

Brake Cylinder

The vehicle brake actuator used by both air and vacuum brake systems and consisting of a cylinder whose piston actuates the [brake block](#) lever.

Brake Frame

An assembly rack for train brake control equipment mounted under or inside a vehicle. Sometimes referred to as a 'brake unit'.

Brake Pad

Composition material used as the friction medium on vehicles equipped with disc brakes. Brake pads for railway vehicles are similar to those used on road vehicles but larger.

They are applied to the braking disc through levers operated by the brake cylinder. Such systems usually require a brake cylinder for each braking disc.

Brake Pipe

The pipe used to control train brakes on vehicles fitted with automatic air or vacuum brake systems. In the US, often referred to as the 'train line'. On air braked trains, when charged, the brake pipe causes the train brakes to be released and the reservoirs (called auxiliary reservoirs) used to apply brakes to be automatically replenished. When pressure in the brake pipe is reduced, train brakes are applied.

Brake Release Valve

A valve provided on each vehicle in a train to allow the brake to be released manually on that vehicle. Sometimes operated by a lever mounted in a suitable location for access by the crew or (on a suitably equipped [EMU](#)) can be operated remotely by the driver in the cab. Some versions have a bleed hole on a brake isolating cock which performs the same function if it is necessary to isolate the brakes of one car from the rest of the train.

Brake Reservoir

Compressed air tank provided to supply [air brake](#) systems with air pressure for brake applications. Modern systems usually require at least one brake reservoir under each vehicle. Originally called the [auxiliary reservoir](#) and still often referred to as such.

Brake Resistor

This is a heat dissipating grid installed on a vehicle equipped with [dynamic braking](#) where the traction motors are used as generators during braking. The grids act much like an electric toaster, heating as the current is applied to them. They absorb electrical energy generated by the traction motors acting as generators during braking and allow it to be transferred to the atmosphere as heat.. They can be mounted on the roof or under the locomotive or car. Underfloor versions are sometimes fitted with fans (called blowers) to help get rid of the heat.

Brake Rigging

The means of distributing the braking forces from a [brake cylinder](#) to the various wheels on the vehicle. It consists of rods and levers suspended from the underframe and bogies and linked with pins and bushes. Rigging requires careful setting up and regular adjustment to ensure forces are evenly distributed to all wheels. Badly set up rigging will cause wheel flats or inadequate brake force.

Brake rigging is now only found on older vehicles where there may only be one or two brake cylinders. More modern systems usually employ one brake cylinder per one of two blocks or per disc.

Brake Systems

A competition to find a safe and reliable form of train braking held in 1875 at Newark, Lincolnshire, UK, showed two clear winners, the [air brake](#), invented by George Westinghouse of the USA and the [vacuum brake](#), of which there were then two examples. Both required a pipe running the length of the train which was used to control the operation of the brakes on every vehicle. Both were controlled from a valve on the locomotive.

The principle of the two systems was the same. When the pipe was charged with compressed air or with a vacuum induced in it, the brake was released. When the pressure or vacuum was lost, the brake applied. Both systems used a cylinder on each vehicle which contained a piston connected to the brake shoes or blocks through [rigging](#) - a system of rods and levers.

The air brake was the clear winner in terms of stopping power and became widely used around the world but the vacuum brake was simpler and cheaper and was eventually adopted by most of the major railway companies in Britain.

The air brake was often called the Westinghouse Brake after its inventor even though many variations of it were and still are, built by other suppliers.

Brake, Types of

* the [air brake](#), which uses compressed air to apply the brakes on each vehicle and as the driver's train brake control medium.

* the [vacuum brake](#), which uses the atmospheric pressure in opposition to a specially created vacuum both to control and actuate the brake.

* the [dynamic brake](#), which uses the electric motors of the traction power system to generate current during braking which is absorbed into a resistor (rheostatic braking) or back into the railway power supply (regenerative braking).

* the [parking brake](#), used to hold an unattended vehicle when the braking system is shut down. Often referred to as the 'handbrake' where it has to be manually applied on each vehicle as opposed to the automatic application provided on the most modern vehicles. Not all vehicles are equipped with parking brakes.

* the track brake, used on some light rail vehicles and trams where large magnets are hung under the vehicle over the rails and current is passed through them to induce a strong magnetic force. The attraction between the magnets and the rails causes the vehicle to stop. Mostly used for emergency braking.

Brake Unit

See [brake frame](#).

Brake Van

A vehicle designed to allow a handbrake or the train brake to be operated by a person other than the driver. Since, in the UK before the advent of [continuous brakes](#), a guard (conductor) was provided to operate the brake on his vehicle to assist the driver stop the train, the "luggage van" was used and it became known as the brake van. On freight trains, the same term was used for the vehicle used by the guard. In the US it is called a "caboose".

Passenger train brake vans were often combined with a passenger coach to form a "brake coach" as in "brake third" denoting a vehicle with a third class passenger section and a guard's position.

Clasp Brakes

A system of [brake rigging](#) where a [brake block](#) is applied to each side of a wheel tread. In essence, the wheel is "clasped" by a pair of brake blocks. Sometimes referred to as "double-block" braking. Normally such designs are arranged so that the two blocks are linked by the rigging and act together but some have individual brake cylinders for each block. In such a case, a 4-wheeled bogie would have eight brake cylinders and a 6-wheeled bogie would have twelve brake cylinders.

Compressor

A motor driven pump mounted on a locomotive or train to supply compressed air for the operation of brakes and other pneumatic systems on the train. Doors, whistles, traction control systems, automatic couplers and window wipers are all devices which can be operated by compressed air.

The air pressure is normally supplied in a range of between 90-110 and 130-140 psi. or roughly 7 - 10 bar (metric). The operation of the compressor is usually automatic, being controlled by a pressure switch or "compressor governor". The pressure switch switches on the compressor when air pressure falls to its lowest permitted level, say 90 psi and switches it off when it has reached its highest permitted level, say 110 psi. At least one

reservoir, called the Main Reservoir, is provided on the vehicle to store the compressed air.

Because compressed air produced by the compressor gets heated during the process, then cools afterwards, condensation occurs. Eventually, water can collect in pipes and reservoirs. It often mixes with the compressor lubricating oil to form a sludge which gets into valves and prevents them working properly. In cold weather, it can freeze and split pipes or reservoirs.

Many compressors are designed to compress the air in two stages. The air passes through cooling pipes after each stage to reduce the condensation and the second set of pipes are designed to allow the air to drain into the main reservoir. There is a water trap and valve in the bottom of the main reservoir which automatically ejects excess water. In many modern designs, an air dryer is provided between the compressor and the main reservoir. The condensation is removed by the drying agent and ejected at the end of the compression cycle as the compressor governor switches off the compressor.

Compressors are normally provided on a locomotive or other vehicle where a power supply is available. In a diesel locomotive the compressor may be driven directly off the engine or off the electrical supply generator. Often, a small, battery-driven auxiliary compressor is provided as well to allow an air supply to be available for starting purposes, e.g. to allow a pantograph to be raised on a "dead" locomotive so it can get power.

A multiple unit train may have two or more compressors located under suitable cars which will supply air to the train through the main reservoir pipe. The operation of the compressors will usually be synchronised via a control wire linked to the compressor governors so that they all operate in unison.

Continuous Brake

Generic term for a train brake which provides for control of the brake on every vehicle in the train and is automatic to emergency stop in the case of loss of control. In other words, it is fail safe. In most countries it is a legal requirement for passenger trains.

The train will automatically stop if the train becomes uncoupled, if brake pipe is ruptured, if a brake valve is opened by passengers or staff and if the compressed air supply fails.

Note that some non-passenger trains do not always have all vehicles fitted with brakes. Such vehicles are sometimes referred to as "swingers".

Digital E-P Brake Control

A development of [electro-pneumatic \(e-p\) brake](#) control is the digital control system. It is normally only used on multiple unit trains. It incorporates the fail-safe features of the air brake but eliminated the need for a brake pipe. The brake pipe is replaced by a "round the train wire" which is permanently energised. As long as it remains energised, the brake remains released. If it loses current for any reason, an emergency application follows.

Each car is equipped with a relay valve with can operate the brake in up to seven steps. Three control wires are used in different combinations to actuate the seven steps of braking. They are de-energised to apply the brake and energised to release. Control is from the driver's brake handle in the cab or it can be by an automatic system such as ATO.

A well-known version of digital brake control is the [Westcode](#) system by Westinghouse.

Disc Brake

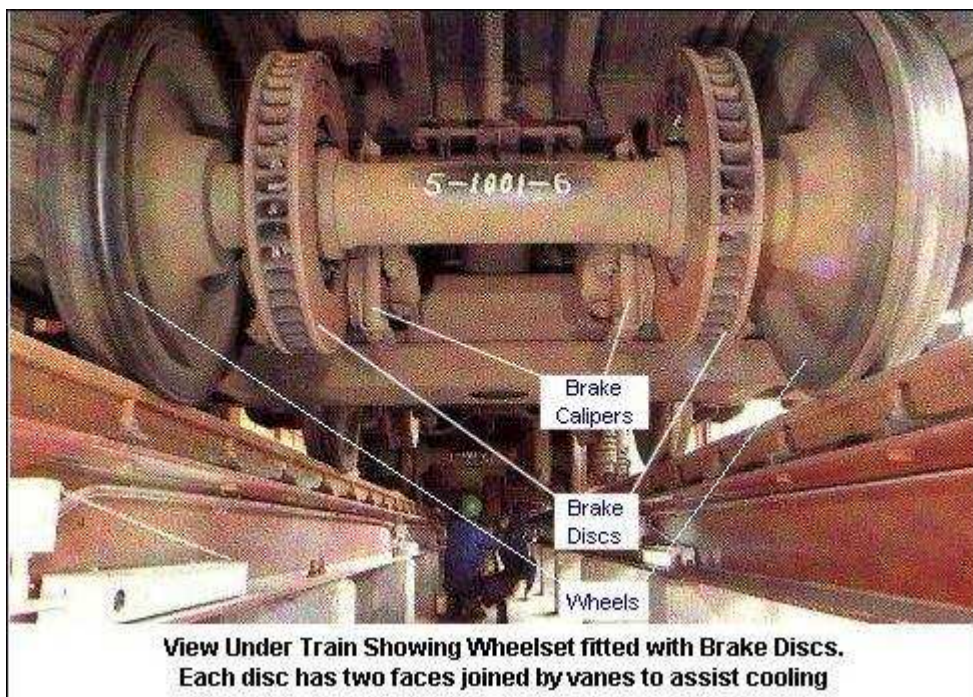

As used on trains, the disc brake (photo left) is similar to the disc brake used on road vehicles but may take the form of a pair of discs mounted either side of the wheel web or a double-sided self-ventilating disc mounted on the axle. Very high speed trains, such as the French TGV, have up to four sets of double discs per axle. The design and number of discs is critical to train safety as they must be capable of dissipating the maximum

amount of heat generated during an emergency brake application from the highest speed attainable by the train. Disc brakes on trains are invariably air operated.

Distributor

Air brake control valve (derived from and known as a triple valve on older systems) mounted on each vehicle which controls the passage of air between the [auxiliary reservoir](#) and the [brake cylinder](#) and between the brake cylinder and atmosphere. The operation of the valve is controlled by changes of pressure in the [brake pipe](#). See also [Air Brake](#).

Driver's Brake Valve

The means by which the train brakes are controlled. On the classic air brake, the driver's brake valve has five positions: Release and Charging, Running, Lap, Application and Emergency. In "Release and Charging" the brake pipe is supplied with air from the main reservoir and the pressure rises to release the brakes and recharge the auxiliary reservoirs. In "Running", the brake remains released but a feed valve, attached to the driver's brake valve, is connected between the main reservoir supply and the brake pipe. This valve holds the brake pipe release pressure against any small leaks in the pipe.

The "Application" position drains air from the brake pipe to apply the brakes. "Lap" is selected when the brake pipe air has fallen to the level required by the driver to give the application he wants. In this position the connection between the brake pipe and the brake valve is closed. In the "Emergency" the brake pipe air is dumped through a large opening in the valve so the air exhausts more quickly than with a normal application. For more details, see [Air Brakes](#).

The [electro-pneumatic brake](#) will also have a driver's brake valve if the air brake is provided as well. Electrical connections are added to the operating spindle so that movement of the handle can operate either brake. Later e-p systems with no brake pipe use what is called a "brake controller", which is simply an electrical controller to change the switch connections to the train control wires as required.

Dump Valve

An electrically controlled valve used to reduce air [brake cylinder](#) pressure in the event of wheel slide or skidding as part of a wheelslip control system. Also the same type of valve is used to reduce air pressure in [air suspension](#) systems when the load on the vehicle is being reduced.

Duplex Gauge

An air gauge located in the driver's cab with two indications - [main reservoir](#) pressure and [brake pipe](#) pressure. Some railways also use a [brake cylinder](#) pressure gauge or gauges in the cab.

Dynamic Braking

A train brake system where the traction motors are used to provide a braking force by reconnecting them in such a way that they become generators. Al Krug, referring to diesel-electric locomotive braking in a reply to a question in a newsgroup, put it this way (slightly edited by me):

Dynamic brakes are fundamentally no different from locomotive air brakes. Both systems convert the energy of the rolling train into heat and then throw away that heat. If you apply the loco air brakes, the brake shoes are pushed against the wheel treads and the resulting friction produces heat. The energy required to produce this heat power makes the loco hard to keep moving. The heat power is thrown away into the air by radiating from the hot brake shoes and hot wheel treads into the surrounding atmosphere.

A loco with air brakes applied is hard to keep moving but it will keep going, particularly if it has energy to move it in the form of a train pushing it from behind. The energy (kinetic energy, it's called) comes from the rolling train that is pushing it. The trouble with using engine brakes alone is that eventually (rather quickly actually) the shoes and wheels get very hot. Hot enough to destroy them. This is because heat is produced faster than it can be dissipated by radiating it into the air. So dynamic brakes are used to move the heat dissipation away from the brake shoes and wheel treads to the dynamic brake grids instead. Like an electric bathroom heater, the dynamic brake grids are designed to handle this amount of heat power (as long as the grid cooling blowers are operating).

Train air brakes work in the same manner as loco air brakes. They convert the rolling energy of the train into heat and throw it away. But when using train brakes, the heat generated is dispersed through out the entire train. It is spread over (say) 800 wheels instead of just the few wheels of the loco. Because of this, the train's wheels do not normally get overheated. They will get warm or even hot but not normally so hot as to cause damage. On prolonged downgrades, however, the braking energy required is sufficient to overwhelm the heat dissipating ability of even all the train's wheels and overheating occurs. This is the main reason for using dynamic brakes, to move the heat dissipation away from the wheels to the dynamic brake grids.

Remember that it takes a 3,000 HP diesel engine just to turn the generator on a 3,000 HP loco. Commercial generating power plants require 100s of thousands of HP to turn the generators that supply your household power. Generators are hard to turn when they are producing power. This is because you never get anything for free. If you take power out of a generator you must put at least equal power into it. (Actually more than equal since nothing is ever 100% efficient either).

In locomotive dynamic brakes, the traction motors are acting as generators. That means the traction motors are hard to turn. The loco's wheels are what are turning the traction motors. They are geared to the traction motors. This means the loco's wheels are hard to turn. They resist turning because they are geared to the traction motors which are hard to turn when generating power, as they are doing when in dynamic braking. Because the loco's wheels are hard to turn when in dynamic braking the loco is hard to move or in other words it resists movement just as if the airbrakes were applied making the wheels hard to turn. The energy required to push this "hard to move" loco comes from the rolling train. This removes energy from the rolling train slowing it.

Note that dynamic brakes are used by electric multiple unit trains as well. In these designs, careful blending with air braking is required to maintain a smooth braking profile. Electronic control is used to determine that the brake effort demanded by the brake controller is matched by the brake effort achieved by the train. Preference is given to the dynamic brake to save wear on brake blocks (shoes) or pads and air braking is added if necessary to achieve the braking rate required.

Dynamic braking can be used on electric railways to convert the energy of the train back into usable power by diverting the braking current into the current rail or overhead line. This is known as regenerative braking. It is used in the same way as rheostatic braking but the energy can be used by other trains requiring power. The power developed by a braking train may not be accepted by the line if no other trains are drawing power so trains equipped with regenerative braking will usually have resistor grids as well to absorb the excess energy. The balance between regenerated current and rheostatic current is also controlled electronically. See also our [Electric Traction Pages Page](#) and under Dynamic Brakes in [North American Freight Train Brakes](#).

EOT Device

An EOT (End Of Train) device is mounted at the rear of a US freight train and is triggered to open a valve on the brake pipe when an emergency application is called for by the driver. A cab unit has a covered switch which, when activated by the driver, sends a radio signal to the EOT. Two-way digital encoding ensures that only the locomotive on

the particular train is capable of activating the valve. The device is battery-powered and provides the train with the rear end red light as well. The system is a legal requirement on US railroads and was instituted over the last couple of years following cases where angle cocks between cars had been closed (in some cases maliciously), rendering those cars remote from the locomotive brakeless.

EOTs are also used to provide an indication that the brake pipe of the train is complete by sending a signal back to the driver's cab when there is a change in pressure.

Early Brake Systems

Originally, the only way to stop a train was by applying a brake to the wheels of the locomotive. A wooden block was applied to the wheel tread. A lever operated by the driver actuated the brake. If more brake power was required, the driver reversed the engine as well. Soon however, it became apparent that this was not enough to bring the train to a stand in a reasonable distance and anyway, the reversing of the wheels damaged the wheel treads, so various vehicles in the train had brakes added. The brake was hand operated by a lever or screw arrangement, so a man was appointed to ride on each of these "[brake vans](#)" as they were called. As trains became heavier and faster, more brake power was required and more brake vans were added.

The principal disadvantages of the manual braking system were that it required additional staff along the train and there was little co-ordination during braking. The driver used the engine to whistle for brakes and to signal for release.

ECP Braking

See ECP brakes page.

Electro-Pneumatic Brakes

For details and graphics see the [E-P Brakes Page](#).

The traditional air brake works well enough in the hands of a skilled driver but it has a number of shortcomings. Its control system relies on the changes in brake pipe pressure to control the application and release of the brakes. This means that a command by the driver to alter the pressure is felt by the front of the train first and then gradually by the rest of the train until it reaches the end. This can cause trouble on a long train if it is not handled carefully, particularly during release when leading vehicles in release mode can pull on rearmost vehicles which still have brakes applied.

The brake pipe is also used to replenish the air reservoirs on each vehicle, a slow process on a long train. Time has to be allowed between successive applications for reservoirs to

recharge. Finally, the automatic air brake has no partial release capability. Once the driver has demanded a release, it will happen and brakes can only be reapplied when the reservoir pressure has recharged to a value higher than the brake cylinder pressure.

What was recognised many years ago was that electrical control could overcome these problems. Since the early 1900s, when electrical control of brakes was tried on the New York Subway, various systems and solutions have been tried.

Most electro-pneumatic brake systems have been designed so that they can be added to the traditional air brake system to allow more rapid responses to the driver's braking commands. For example, in the simple version used on the UK High Speed trains, each end of the train has an electrically operated valve. When an application is called for at one end, the valve opens the brake pipe at the other end so that both ends are exhausting air at the same time. A simple version of this, called an [EOT](#) (End of Train device) is used on US freight trains for emergency application.

A earlier development first tried on multiple unit trains in the UK in the 1920s, consisted of a system whereby the application and release of the brake was achieved by electrically controlled valves on each vehicle. It was originally designed early this century for rapid transit trains in the US to overcome the natural delay which occurs due to the propagation of the pure [air brake](#) and quickly adopted in Europe. Normally the electrical control is additional to and superimposed upon the automatic air brake, although more recent systems incorporate a fail safe electrical control which eliminates the need for a separate brake pipe. See [digital](#) and [analogue](#) e-p systems.

A basic e-p brake system as applied to a multiple unit train comprises an electrically operated "holding valve" and "application valve" on each car together with control wires running the length of the train. The main reservoir is also connected to each car on the train by a main reservoir pipe. Often more than one main reservoir is provided. Usually, each car also has an "e-p brake reservoir".

The e-p brake operates independently of the air brake. It uses main reservoir air instead of brake pipe air and the air brake and triple valves are kept in the release position. The e-p brake is controlled from the same driver's brake valve as the air brake but using new positions to apply and release the e-p brake. Electrical connections attached to the driver's brake valve send commands along the train to the holding and application valves on each car.

To apply the brake the driver selects "Application", which causes all holding and application valves to energise. The holding valve closes off the brake cylinder exhaust and the application valve opens to admit main reservoir air into the brake cylinder. The

brakes apply. Selecting "Release" de-energises the valves, closing the application valve and cutting off the main reservoir pipe connection and opening the holding valve to allow brake cylinder air to exhaust.

The advantage of the e-p system is that it allows instantaneous reaction on all cars at the same time and it allows small and graduated applications and releases. This gives accurate and rapid stopping, which is particularly important in suburban and rapid transit operations.

E-P brakes are not normally used on freight trains because of the diversity of wagons and the cost of conversion. Also, getting an electric signal to transmit at a low voltage down a very long train is difficult. Radio control has been suggested, as has fitting each car with a battery. Some experimental e-p systems are being tried in the US in an attempt to improve brake control. The real test however, will be the willingness of railway companies to spend time and money doing the conversions.

Empty/Load Lever

A device for varying braking on freight cars so that braking is adjusted in accordance with the weight of the vehicle. In its usual form, a lever at the side of the wagon has two positions, "Empty" and "Loaded". Changing the position of the lever adjusts the [brake rigging](#) so that the brake force is adjusted to compensate for the empty or loaded condition of the vehicle.

Equalising Reservoir

Air reservoir employed in air braking systems to provide the driver with brake control valve with a greater degree of flexibility and to create a cushion for brake pipe control between the driver's manually operated brake valve and the brake pipe. For more details see North American Freight Train Brakes.

Exhauster

A pump, usually electrically driven, which removes air from the [brake pipe](#) of a train equipped with the [vacuum brake](#). Equivalent to the [compressor](#) on an [air brake](#) system. Performs the same function as the ejector on a steam locomotive. Exhausters are usually designed to run at two speeds - slow speed to maintain the vacuum against small leaks and losses along the brake pipe and high speed to get brakes released after they have been applied.

Feed Valve

A pressure regulating valve provided in the driver's cab to allow the brake pipe pressure to be held at a constant level while the train is running with the brake released. Some railways, notably those in the US, allow this valve to be adjusted by the crew. See also [Driver's Brake Valve](#) and [North American Freight Train Brakes](#).

Flats

A damage spot on a wheel tread caused by the wheel locking and skidding during braking. The skidding is caused by reduced adhesion between wheel and rail and it will extend the braking distance required for a given brake application. The flats will be heard as the train restarts and will continue until the wheel treads are reprofiled in the workshop. Severe flats are considered dangerous as they may cause derailments at points so they can cause a train to be removed prematurely from service.

The problem of flats has become worse as passenger rolling stock, particularly multiple unit trains, has tended to become lighter, thus reducing the adhesive weight. Further problems have developed with the trend towards disc brakes instead of tread brakes. At least with a tread brake, the action of the block rubbing against the wheel had a scrubbing effect on the surface and helped keep it clean.

In many countries where there is a leaf fall season, the effect of crushed leaves on rails has caused significant problems with adhesion. Some lines are forced to introduce temporary speed restrictions and, in London, England, a special leaf fall timetable was used on one line where times were increased to compensate for longer braking times at stations.

Foundation Brake Gear

Another term to denote [brake rigging](#) which distributes braking forces around to the wheels of a vehicle having only one or two [brake cylinders](#).

Friction Brake

The most common type of brake used by trains, it acts by dissipating the kinetic energy of the moving train by converting the energy into heat. The heat arises from the friction between the brake pad and the brake disc or between block and wheel tyre during braking. See also [Dynamic Brake](#).

Graduated Release

One drawback of the basic air brake system is that there is no way of gradually releasing the brakes. To release the brakes, the driver will recharge the brake pipe using the "driver's brake valve". Once the air pressure in the brake pipe start to build up, the triple

valves detect this rise in pressure and move to the release position and exhaust brake cylinder air.

Handbrake

Nowadays synonymous with the term [parking brake](#) but originally a vehicle brake applied by hand action to a wheel or lever on the vehicle.

Hose

Braking and other systems on the train use compressed air both as a power source and a control medium. The connections between vehicles are through flexible pipes usually referred to as hoses. Hoses are normally equipped with [isolating cocks](#) to shut off the supply and bleed the hose when vehicles are uncoupled.

Isolation

Under various conditions, it is necessary to isolate portions of or the whole brake system. For this purpose, isolating cocks are positioned in suitable locations. The most obvious isolating cocks are called [angle cocks](#) and these are used to allow vehicles to be pneumatically isolated when uncoupled.

Another isolating cock is provided in the pipe connecting the main reservoir to the driver's brake valve. It is important to ensure that this cock is closed on any locomotive where the brake control is not being used so that air does not get into the brake pipe while the driver is trying to apply the brake from another driving position.

On e-p brake equipped vehicles, it is common to allow the equipment to be pneumatically isolated so that the air brake can be used instead.

Various isolating cocks with bleed holes are fitted to allow reservoirs to be drained so that equipment can be worked on safely or reservoirs can be drained of water which appears from condensation.

Main Reservoir

Compressed air storage tank provided on trains to supply pneumatic systems including brakes. See [Compressor](#) for details.

Main Reservoir Pipe

An air pipe provided on multiple-unit trains to supply pneumatic equipment located along the train such as doors, brakes etc. connecting all main reservoirs on a train from which supplies for pneumatic systems are drawn. Connections between cars are via

flexible [hoses](#). Normally, each vehicle has main reservoir pipe isolating cocks at each end of the pipe to allow uncoupling of hoses without loss of main reservoir pipe pressure.

One Pipe/Two Pipe Systems

The main disadvantage of a train braking system using an air pipe to control the brakes is the propagation time - the time taken for a change in pressure to reach all the vehicles. The longer the train, the greater is this time. Some long US freight trains may take as long as 15 minutes to recharge a completely airless brake system. Even on a short train, with a fully charged brake system, it may take several seconds for the rear vehicle to respond to changes in brake pipe pressure.

One way of reducing the recharge time and getting a quicker release of brakes is to use a second pipe. The second pipe is the main reservoir pipe, which is recharged directly from the compressor. It is constantly kept at full pressure, regardless of the status of the brake pipe pressure. When brake release is selected, the distributors on each vehicle use this main reservoir air to recharge the auxiliary reservoirs instead of using brake pipe air as on the one pipe system. During an application, some systems add main reservoir air to the brake cylinders to speed up operation.

The two-pipe systems is also a feature of some [electro-pneumatic brake](#) systems.

P-Wire Control

A short form of "Pulse Width Modulation brake control". A type of electro-pneumatic brake control; see Analogue E-P Brake.

Parking Brake

Means by which an unattended or unpowered vehicle can be secured against unplanned movement. Usually consists of a manually applied friction brake applied to the wheel tread or disc. Some recent developments include spring-applied parking brakes, which release when compressed air for the [air brake](#) is available, and pneumatically applied systems.

Pinning Down the Brakes

A term used in the days of freight train operation when some or all the wagons in a freight train had no continuous brake, only a hand brake. The hand brake was operated by a lever on the outside of the wagon and held down in the application position by a pin in a hole. Freight trains about to descend a gradient would stop and the guard would "pin down the brakes" on some vehicles to control the speed. At the bottom of the gradient, the train would stop again and the brakes would be released manually.

Propagation Rate

The rate at which the change in air pressure initiated by the operation of the driver's brake valve travels along the brake pipe. Because it takes time for the reduction (or increase) in pressure to travel along the brake pipe, the brake applies (or releases) at different times on different vehicles. This affects the control of the train and can cause bunching or stretching of vehicles putting additional strain on the couplings, particularly on long, heavy trains. Skill is required by the driver of a heavy freight train to ensure that operation of the brakes does not cause a train to break apart or even derail.

Regenerative Braking

A braking system used by locomotives and trains fitted with electric traction motors where the motors become generators and the current developed is fed into the overhead line or third rail for use by other trains or for return to the supplier. For more details, see Dynamic Braking.

Retainer

A manually operated valve mounted on many US freight cars to provide a constant minimum application even though the brake has been released from the driver's brake valve in the cab. Normally, when brakes are released, all of the air in the brake cylinders is discharged to the atmosphere. By setting retainer valves, when the brakes are released, some of the air pressure is "retained", hence the name. If set for say 10 psi, the brake cylinder pressure will not drop below 10 psi until the retainer is reset (or until the air eventually seeps out). Typically, a certain number of cars on the rear of the train would have their retainers set by the conductor. Rulebooks indicate how many retainers to set before descending.

There are 2 types of retainer valves, a 3 position type and a 4 position type. The operating positions are:

- EX- Exhaust, normal will not retain air
- HP-High Pressure, will retain 20psi
- SD-Slow Direct Exhaust, will not retain air but will exhaust the air more slowly than normal
- LP-Low Pressure, will retain 10psi, only available on the 4 position retainer valve.

If you make a stop on a grade and have to release the air brakes to recharge the system, then before you release the air brakes you must apply a sufficient number of hand brakes to secure the train if you are not sure the locomotive brakes will hold the train. Depending on conditions, that may mean every hand brake on the train. (I know I would

not want to be the conductor who had to set 100 hand brakes.) After that job is completed then the air brakes can be released and the system may be recharged. If you do attempt to use the locomotive brakes to hold the train and it turns out that they are not sufficient to hold the train you may not have enough air left to stop the train again.

Written with newsgroup contributions from David Gianna and Donald Reventlow. See more in [North American Freight Train Brakes](#).

Rheostatic Braking

A braking system used by locomotives and trains fitted with electric traction motors where the motors become generators and the current developed is fed to on-board resistor grids. The energy is dissipated as heat as the grids cool. Some grids have to be force-ventilated to dispose of the heat quickly enough. Rheostatic braking is useful for diesel-electric locomotives with heavy freight trains on long down grades. For more details, see [Dynamic Braking](#).

Self-Lapping Brake Valve

A type of driver's brake valve where the position of the valve operating handle between "brake off" and "full application" determines the rate or level of brake application. This type of brake valve can be seen on some air braked and e-p braked trains.

Slack Adjuster

Most modern rail vehicles have brake cylinders equipped with slack adjusters. The slack adjuster automatically compensates for the wear induced in the block or pad during braking. It operates usually with some form of ratchet system fitted internally or as part of the brake cylinder assembly.

Slip/Slide Control

A critical feature of the railway environment is the interface between wheel and rail. This interface is dependent upon the adhesion between the steel surface of the wheel tread and the steel surface of the rail head. The relationship is defined as the coefficient of friction. On a dry day is this is about 0.3, on a wet day 0.2 with clean rails. A figure of 0.1 is allowed for normal braking and 50% of that added as a safety margin to prevent overrunning. Values under 0.05 will occur in conditions where the rail head is contaminated by leaves or ice.

The coefficient of friction figures relate to circumstances where there is no sliding action between wheel and rail. Tests have shown that braking distances will increase considerably if the wheels slide during braking. There is nothing worse for a driver who

applies the brake and then sees the speedometer drop instantly to zero. He knows he will not be able to stop in the right place. There will also be wheel damage, called [flats](#).

Detection: In order to reduce the likelihood of excessive braking, many locomotives and multiple units are fitted with wheel slip/slide control systems. The most common of these operates rather like ABS (automatic braking systems) on road vehicles. The railway systems usually monitor the rotation of each axle and compare rotational speeds between pairs of axles. If a difference appears between a pair of axles during braking, the brake is released on those axles until the speeds equalise, when the brake is re-applied. All this occurs automatically. Modern systems also detect too rapid deceleration of an axle. Another form of slip/slide detection uses Doppler radar techniques. This measures the ground speed of the locomotive against the revolutions of each wheelset and uses the detection of a difference to regulate the control systems.

Practice: The purpose of a wheel slide protection system is to reduce wheel damage. If anyone was to suggest that it should allow the train to stop safely within the normal braking distance for a given degree of application, they would be wrong. What slip/slide control can do is to regulate the braking to within 10-20% of the best available adhesion. Nevertheless, in practice, the effect of poor railhead conditions lengthens the actual braking distance over that normally required with good rail conditions. To a driver, this makes his braking distance longer because he will normally start braking according to position and not according to speed.

A section of line over which a driver passes often will allow him to determine over time that the best point to commence braking in order to stop at, say, a station is in a particular position, using a landmark - tree, signal post, bridge or something similar. This assumes that the train speed is usually the same each time he passes this point.

The theoretical concept for slip/slide control would only be valid if the driver knew in advance that the wheel rail adhesion would be reduced and made a normal application of the brakes in advance of the usual braking commencement point. Because of the reduced adhesion, the normal application would induce the wheel slide control and, instead of stopping short of the correct position as he would have done with a dry rail, the train will stop in the correct position under the control of the wheel slide protection system.

ATO: Wheel slide control has further limitations when in use on an automatic train operation (ATO) system. On suburban commuter lines, subways and metros, many of which use ATO systems, rapid braking is necessary to reduce the headway and the train control system is designed to do just this. It would require some pretty sophisticated detection systems to alert the ATO to poor adhesion if wheel slide was to be

automatically controlled and safe braking distances adhered to. An accident on the Washington subway system a few years ago was caused by a train sliding on iced rails whilst braking into a station, failing to stop in the correct distance and hitting a parked train beyond the station. Most ATO systems used on open lines have additional margins built into the braking control to compensate for poor adhesion.

In many instances, the wheel slide control is combined with wheel slip control. Wheel slip occurs during acceleration and is therefore not part of the braking system. It has however, become pretty sophisticated with [creep control](#) allowing good acceleration with virtually no equipment damage.

Spring Applied Parking Brake

A system for automatically applying a parking brake to a vehicle when the automatic air brake pressure is not available. Manually operated parking brakes can be forgotten by the crew - forgetting to apply them (or enough of them) when stabling a train or forgetting to release them before moving a train. The latter is a common problem which causes wheels to be dragged and damaged by [flats](#). The spring applied parking brake attempts to overcome these problems.

The principle of operation is that the brake is held released by air pressure and is applied by a spring when the pressure is lost. It acts in the opposite way to the air brake. There are also remotely applied spring parking brake systems available, which can be activated from a push button in the driver's cab. Quite why this complication is necessary escapes me but some railway administrations insist on it.

Straight Air Brake

A simple compressed air brake fitted to locomotives for use on the locomotive only. It comprises an air supply ([compressor](#)), a driver's brake valve and connections to the [brake cylinders](#). There is no automatic safety feature as is provided on automatic train brakes. The driver's straight air brake valve is normally provided separately from the train brake valve and is operated independently from it. However, use of the train brake will operate the locomotive brakes, unless the driver operates a special isolating feature. For details see [North American Freight Train Brakes](#).

Train Brakes

During the early 19th century various attempts were made to get away from the concept of vehicle brakes which had to be individually controlled and provide a train brake with one point of control. A scheme of 1840 had a chain which ran along the train to the guard's position at the rear where it was wound round a drum. To apply the brake the

drum was lowered until it touched an axle, causing it to rotate and tighten the chain. Levers connected to the chain applied the brakes. Variations of this idea all suffered from the problem of breakages and the effects on the brake chain caused by the compressing of the couplings between vehicles.

In addition, as railways developed during the mid 18th century, there were a number of accidents caused by trains becoming uncoupled (a breakaway) or just failing to stop. Sometimes, breakaways ran down a grade and collided with the following train or trains became parted and the second half ran into the front half after the crew had stopped it because they had noticed the uncoupling.

Some form of safeguard against these problems was needed and various ideas were put forward to provide brakes on every vehicle (so-called [continuous brakes](#)) and to control them from the locomotive. Various methods were tried, including ropes, chains and pipes running along the length of the train until it was decided to hold a competition at Newark, Lincolnshire in the UK in 1875 to find the best practical solution.

Train Line

In UK parlance, a cable running the length of a train for any train control or power purposes. The term train line is sometimes used in the US and on London Underground to denote the [brake pipe](#).

Tread Brake

The traditional form of wheel brake consisting of a block of friction material (which could be cast iron, wood or nowadays a composition material) hung from a lever and being pressed against the wheel tread by air pressure (in the [air brake](#)) or atmospheric pressure in the case of the [vacuum brake](#). Now the preferred system is a [disc brake](#) which, by replacing the tread brake, removes one of the causes of wear on wheel treads, although it also removes the scrubbing action which tended to reduce the risk of [wheel slide](#).

Triple Valve

The principal control valve mounted on each vehicle fitted with air braking. So-called because it has three functions - to apply the brake, to hold the application at a constant level and to release and recharge the brake system. It also has (in its original form) three connections - to the brake pipe, to the brake cylinder and to the auxiliary reservoir.

Later versions of the original triple valve had a "[quick acting](#)" function brought into operation upon an emergency application or rapid discharge of brake pipe air. Recent

developments have seen the original metallic valves replaced by flexible diaphragms and additional features like "quick release", "graduated release" and connections to emergency reservoirs added.

Triple Valve Operation

The triple valve operates by detecting differences in air pressure between the brake pipe, the brake cylinder and the auxiliary reservoir. To see how it works in detail, try this link at our page on [Air Brakes](#). This provides a useful description of the air brake control system as it is used world wide.

Vacuum Brake

For details and graphics see the [Vacuum Brakes Page](#).

The automatic braking system where the brakes on each vehicle are actuated by the action of atmospheric pressure over a pre-formed vacuum. The [brake pipe](#)- is normally evacuated by a motor driven [exhauster](#) to create a vacuum and release the train brakes.

The vacuum developed in the brake pipe is measured in inches of mercury and is usually in the range of 21 to 25 inches for a fully charged system. As the degree of vacuum was by no means standardised in the UK, this caused some problems on joint services. For example, cases are recorded where Southern Railway engines could not release the brakes on Great Western Railway trains because the GWR vacuum was higher and the SR engines could not create sufficient vacuum to equalise throughout the train. They had to destroy the vacuum completely and start again this causing delays.

The system has fewer valves than the equivalent air brake system but it has the disadvantage that response time and braking distances for a given weight of train are usually longer over 50% in most cases.

In an attempt to speed up the propagation rate, later versions were fitted with accelerator valves on each vehicle. As soon as this valve detected a reduction in vacuum level, it admitted air locally into the brake pipe and brake cylinder, thereby speeding up the application. As soon as vacuum pressure was restored, the valve closed to prevent further air intake.

One big advantage of the vacuum brake is the ability to graduate release as well as application. The air brake triple valve was designed to allow a graduated application but, once set in the release position, it could not stop the release until the air pressure in the auxiliary reservoir was restored. Modern air braking systems are designed to overcome this and allow graduated release.

The vacuum brake is obsolete as far as railway braking is concerned but it is still used by those older equipped lines around the world which were based on British practice. For example, there are still EMUs operating in South Africa with vacuum brakes.

Variable Load Valve

Also known as a Retainer. A valve used to vary brake application individually on each vehicle depending on the weight of the vehicle, it can be manually or automatically operated. In the manual version used on freight vehicles only a lever at the side of the wagon must be set for the required position. For details of the system used in the US see [Retainers](#).

Automatic versions of variable load valves are now often used. A simple version is operated by a lever connected between the valve mounted on the car underframe and the bogie frame. As the car load increases, the lever detects the depression of the car body and valve relative to the bogie and adjusts the setting of the valve in direct proportion. See also North American freight Train Brakes - [Empty/Load Sensors](#).

On vehicles with air suspension, the lever is used to adjust a [levelling valve](#) which changes the air pressure in the suspension system so that the car body maintains a constant height, regardless of the load. Changes in the suspension air pressure are detected by a separate variable load valve and the brake application adjusted to suit.

The variable load system can also be used to adjust train acceleration so that it is constant regardless of load.

Westcode Brake

Proprietary train braking system by the Westinghouse Co. of the UK using a 7-step relay valve on each vehicle controlled by three train wires. It has a [digital control](#) system, with an additional round-the-train-wire designed to replace the brake pipe and energised-to-release control wires to give [electro-pneumatic brake](#) control. The control is fail-safe by causing an emergency brake application if either the signal on the train wires or the electrical supply is lost.

Wheel Slide

See [Slip/Slide Control](#)

7.2. ELECTRIC LOCOMOTIVE GLOSSARY

7.2.1. Introduction

This page offers a selection of terms used in electric locomotive traction.

7.2.2. Electric Locomotive Parts

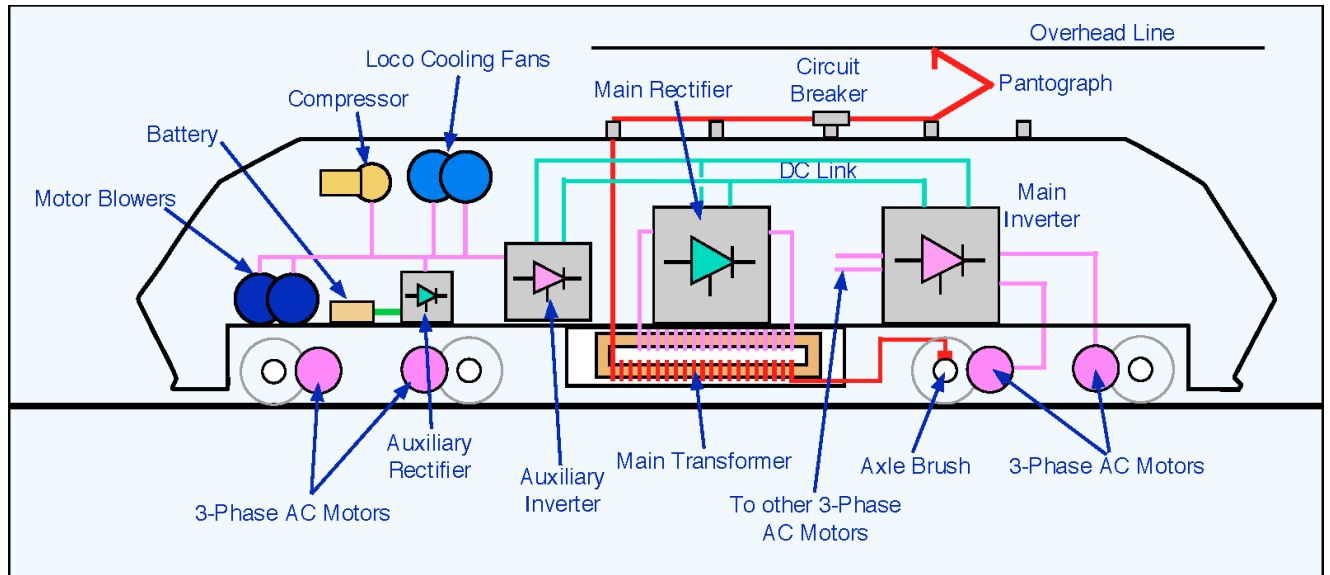

This diagram shows an AC electric locomotive, i.e a locomotive collecting AC power from an overhead line. The red lines on the diagram indicate the single phase AC circuit, the green lines the DC circuits and the purple lines the 3-phase AC circuits. A locomotive using DC traction current is similar, except that there is no single phase AC circuit or transformer. The current passes directly from the pantograph (or shoe) to the main and auxiliary inverters.

Asynchronous Motor

Modern traction motor type using three phase AC electrical supply and now the favoured design for modern train traction systems. Can be used on DC and AC electrified railways with suitable control electronics and on diesel-electric locomotives. See the article on AC and DC Motors.

Axle Brush

The means by which the power supply circuit is completed with the substation once power has been drawn on the locomotive. Current collected from the overhead line or third rail is returned via the axle brush and one of the running rails. See also [Power Supply - return](#).

Battery

All trains are provided with a battery to provide start up current and for supplying essential circuits, such as emergency lighting, when the line supply fails. The battery is usually connected across the DC control supply circuit.

Bucholz Relay

A device inserted in the oil cooling circuits of electric locomotive transformers to detect low oil pressure. In this event the relay trips out the power system. Often a source of spurious circuit breaker trips if not carefully calibrated.

Camshaft

Most DC electric traction power circuits use a camshaft to open or close the contactors controlling the resistances of the traction motor power circuit. The camshaft is driven by an electric motor or pneumatic cylinder. The cams on the shaft are arranged to ensure that the contactors open and close in the correct sequence. It is controlled by commands from the driver's cab and regulated by the fall of current in the motor circuit as each section of resistance is cut out in steps. The sound of this camshaft stepping can be heard under many older (pre electronics) trains as they accelerate. See also [Notching Relay](#).

Cannon Box

Sleeve used to mount a traction motor on axle in electric power bogies and sometimes including an [axle brush](#).

Chopper Control

A development in electric traction control which eliminates the need for power resistors by causing the voltage to the traction motors to be switched on and off (chopped) very rapidly during acceleration. It is accomplished by the use of thyristors and will give up to 20% improvement in efficiency over conventional resistance control.

Circuit Breaker

An electric train is almost always provided with some sort of circuit breaker to isolate the power supply when there is a fault, or for maintenance. On AC systems they are usually on the roof near the pantograph. There are two types - the air blast circuit breaker and the vacuum circuit breaker or VCB. The air or vacuum part is used to extinguish the arc which occurs as the two tips of the circuit breaker are opened. The VCB is popular in the UK and the air blast circuit breaker is more often seen on the continent of Europe.

Contactor

Similar to a [relay](#) in that it is a remotely operated switch used to control a higher power local circuit. The difference is that contactors normally latch or lock closed and have to be opened by a separate action. A lighting contactor will have two, low voltage operating coils, one to "set" the contactor closed to switch on the lights; the other to "trip" off the lights. Click [here for diagrams](#) and more detail.

Converter

Generic term for any solid state electronic system for converting alternating current to direct current or vice versa. Where an AC supply has to be converted to DC it is called a rectifier and where DC is converted to AC it is called an inverter. The word originated in the US but is now common elsewhere.

Cooling Fans

To keep the thyristors and other electronic power systems cool, the interior of a modern locomotive is equipped with an air management system, electronically controlled to keep all systems operating at the correct temperature. The fans are powered by an auxiliary inverter producing 3-phase AC at about 400 volts.

Creep Control

A form of electronically monitored acceleration control used very effectively on some modern drive systems which permits a certain degree of wheel slip to develop under maximum power application. A locomotive can develop maximum slow speed tractive effort if its wheels are turning between 5% and 15% faster than actually required by the train speed.

DC Link

Used on modern electronic power systems between the single phase rectifier and the 3-phase inverter. It is easier to convert the single phase AC from the overhead line to the 3-phase required for the motors by rectifying it to DC and then inverting the DC to 3-phase AC.

Dynamic Braking

A train braking system using the traction motors of the power vehicle(s) to act as generators which provide the braking effort. The power generated during braking is dissipated either as heat through on-board resistors ([rheostatic braking](#)) or by return to the traction supply line ([regenerative braking](#)). Most regenerative systems include on

board resistors to allow rheostatic braking if the traction supply system is not receptive. The choice is automatically selected by the traction control system. See also the [Dynamic Brake](#) section of our [Brakes Page](#).

Earth Fault Relay

See [Ground Relay](#).

Grid

Train or locomotive mounted expanded steel resistor used to absorb excess electrical energy during motor or braking power control. Often seen on the roofs of diesel electric locomotives where they are used to dissipate heat during [dynamic braking](#).

Ground Relay

An electrical relay provided in diesel and electric traction systems to protect the equipment against damage from earths and so-called "grounds". The result of such a relay operating is usually a shut-down of the electrical drive. Also sometimes called an Earth Fault Relay.

GTO Thyristor

Gate Turn Off thyristor, a thyristor which does not require a commutation (reverse flow circuit) circuit to switch it off. See [Thyristor](#)

IGBT

Most recent power electronics development. It is replacing the GTO thyristor as it is smaller and requires less current to operate the switching sequences. See [Transistor](#) upon which the technology is based.

Inverter

Electronic power device mounted on trains to provide alternating current from direct current. Popular nowadays for DC railways to allow three phase drive or for auxiliary supplies which need an AC supply. See also [converter](#) with which it is often confused.

Jerk Limit

A means by which starting is smoothed by adjusting the rate of acceleration of a train by limiting the initial acceleration rate upon starting. It could be described as limiting the initial rate of change of acceleration. Also used in dynamic braking.

Line Breaker

Electro-mechanical switch in a traction motor power circuit used to activate or disable the circuit. It is normally closed to start the train and remains closed all the time power is required. It is opened by a command from the driving controller, [no-volts](#) detected, [overload](#) detected and (were required) [wheel spin](#) or slide detected. It is linked to the overload and no-volt control circuits so that it actually functions as a protective circuit breaker.

Master Controller

Driver's power control device located in the cab. The driver moves the handle of the master controller to apply or reduce power to the locomotive or train.

Motor Blowers

Traction motors on electric locomotives get very hot and, to keep their temperature at a reasonable level for long periods of hard work, they are usually fitted with electric fans called motor blowers. On a modern locomotive, they are powered by an auxiliary 3-phase AC supply of around 400 volts supplied by an auxiliary inverter.

Notching Relay

A DC motor power circuit relay which detects the rise and fall of current in the circuit and inhibits the operation of the resistance contactors during the acceleration sequence of automatically controlled motors. The relay operates a contactor stepping circuit so that, during acceleration of the motor, when the current falls, the relay detects the fall and calls for the next step of resistance to be switched out of the circuit. See [DC Resistance Control](#) and Camshaft.

No-Volt Relay

A power circuit relay which detected if power was lost for any reason and made sure that the control sequence was returned to the starting point before power could be re-applied. See [Motor Protection](#).

Overload Relay

A power circuit relay which detected excessive current in the circuit and switched off the power to avoid damage to the motors. See [Motor Protection](#) above.

Pantograph

The current collection system used by locomotives and trains on routes electrified with overhead lines. The pantograph (often shortened to "pan") is held up by compressed air pressure. It is designed to collapse if it detects an obstruction. It can also be lowered manually to isolate the locomotive or train.

Rectifier

A converter consisting of thyristors and diodes which is used to convert AC to DC. A modern locomotive will usually have at least two, a "Main Rectifier" for the power circuits and one or more for the auxiliary circuits.

Relay

A remotely controlled switch which uses a low voltage control circuit. It will close (or open) a switch in a local circuit, usually of higher power. To see the principle of how it works, look [here](#). See also [Contactor](#).

Resistance Control

Method of traction motor control formerly almost universal on DC electric railways whereby the power to the motors was gradually increased from start up by removing resistances from the power circuit in steps. See more [here](#). Originally this step control was done manually but it was later automatic, a relay in the circuit monitoring the rise and fall of current as the steps were removed. Many examples of this system still exist but new builds now use solid state control with [power electronics](#).

SEPEX

Short form of SEParate EXcitation of traction motors where the armature and field coils of an electric motor are fed with independently controlled current. Click [here](#) for diagrams. This has been made much more useful since the introduction of [thyristor control](#) where motor control can be much more precise. SEPEX control also allows a degree of automatic wheel slip control during acceleration.

Shoegear

Equipment carried by a train and used for current collection on track mounted (third rail) power supply systems. Shoegear is usually mounted on the bogies close to the third rail. It is often equipped with devices to enable it to be retracted if required to isolate the car or on-board system which it supplies. See also the [Power Supply](#) page.

Synchronous Motor

Traction motor where the field coils are mounted on the drive shaft and the armature coils in the housing, the inverse of normal practice. Favoured by the French and used on the high speed TGV Atlantique trains, this is a single-phase machine controlled by simple inverter. Now superseded by the asynchronous motor.

Tap Changer

Camshaft operated set of switches used on AC electric locomotives to control the voltage taken off the main transformer for traction motor power. Superseded by thyristor control.

Thyristor

A type of diode with a controlling gate which allows current to pass through it when the gate is energised. The gate is closed by the current being applied to the thyristor in the reverse direction. Thyristors (also referred to as choppers) are used for traction power control in place of resistance control systems. A GTO (Gate Turn Off) thyristor is a development in which current is turned off by applying a pulse of current to the gate.

Transformer

A set of windings with a magnetic core used to step down or step up a voltage from one level to another. The voltage differences are determined by the proportion of windings on the input side compared with the proportion on the output side. An essential requirement for locomotives and trains using AC power, where the line voltage has to be stepped down before use on the train.

Transistor

The original electronic solid state device capable of controlling the amount of current flowing as well as switching it on and off. In the last few years, a powerful version has been applied to railway traction in the form of the Insulated Gate Bipolar Transistor (IGBT). Its principle advantage over the GTO Thyristor is its speed of switching and that its controls require much smaller current levels.

Wheel Spin

On a steam locomotive, the driver must reduce the steam admission to the cylinders by easing closed (or partially closed) the throttle/regulator when he hears the wheels start to spin. On diesel or electric locomotives, the current drawn by individual or groups of traction motors are compared - the motor (or group) which draws proportionally less

amps than the others is deemed to be in a state of slip - and the power is reduced. Some systems - EMD Super Series for one - measure known wheel speed against ground speed as registered on a Doppler Radar. Many locomotives additionally use sand, which is applied to the wheel/rail contact point to improve adhesion - this is either controlled automatically, or manually by the driver (Foamer? No Way, 25 Apr 98). See also Wheel Spin Relay.

Wheel Spin Relay (WSR)

A relay in older traction motor control circuits used to detect wheel spin or slide by measuring the current levels in a pair of motors on a bogie and comparing them. The idea is to prevent motor damage by preventing an overspeeding motor causing an unacceptable rise in current in the other motor of the pair. If detected, the imbalance causes the control circuits to open the line breakers and reset the power control to the start position like a ["no-volt"](#) relay.

7.3. STEAM GLOSSARY

An explanation of its design, operation, maintenance and some history in glossary format.

A

ADHESION

The grip of the driving wheels of a locomotive obtained on the rail, particularly important when starting. The weight on the driving wheels is particularly helpful in this respect.

ADHESIVE FACTOR

The ratio of maximum tractive effort, expressed in pounds, to the [adhesive weight](#), also in pounds, of a locomotive. It will usually be about 25% of the adhesive weight for a locomotive with two or four cylinders. For a locomotive with three cylinders, the adhesive factor might be reduced to 3.5 to 1.

ADHESIVE WEIGHT

The adhesive weight is that part of the locomotive weight carried on the driving wheels which can therefore contribute towards adhesion. See also [Adhesive Factor](#).

ADMISSION, STEAM

In steam engine operation, the period during which the steam valve exposes the steam port to allow live steam to enter the cylinder. The admission period is restricted to a percentage of the piston stroke. See also [Cut off](#) and [expansion](#).

ADRIATIC TYPE LOCOMOTIVE

A locomotive with a 2-6-4 [wheel arrangement](#), first introduced in 1909 on the Austrian State Railway and said to have been named after its use on a route by the eastern shore of the Adriatic Sea.

AIR BRAKE

Standard train brake originating in the US using compressed air in which the control is actuated from a driver's brake valve. A fall in brake pipe air pressure causes a brake application on each vehicle whilst a restoration of pressure causes the brake to release. A triple valve on each vehicle monitors the pressure in the brake pipe. When pressure falls, the distributor allows air from an auxiliary reservoir on the vehicle to pass to the brake cylinders to apply the brake. When pressure rises, the triple valve releases the

air from the brake cylinder and recharges the auxiliary reservoir for the next application, using air from the brake pipe as it recharges. See more information in our [Brakes Page](#).

Air brakes were not popular on most UK steam railways, who preferred the vacuum brake on account of its simplicity and cheapness.

AIR OPERATED REVERSER

Sometimes used on locomotives equipped with [compressors](#) for [air brake](#) operation. William Stroudley of the London & Brighton & South Coast Railway used such a reverser in 1882. It was widely used in the US where [valve gear](#) became too large to be operated manually.

ALLAN VALVE GEAR

A type of [valve gear](#) designed by Alexander Allan, one time locomotive superintendent of the LNWR, in 1855. It was similar to the Stephenson valve gear but the reversing lever moved both the [link](#) and the block at the same time instead of only the link. It enabled the link to be made straight and of less vertical height. See also [Link Valve Gear](#).

ANTI-VACUUM VALVE

Also known as a 'snifting valve'. A valve provided on engines with [piston valves](#) to allow air into the steam passages while the locomotive is moving with the [regulator](#) closed. In this condition, the pistons act as pumps, trying to drag air into the cylinders and compress it. A partial vacuum is created in the [steam chest](#) and this can drag ash into it from the [smokebox](#). Anti-vacuum valves provide some relief of this problem at low speed with a long cut off but will not help much at higher speeds. For this reason, drivers normally open the [regulator](#) a little (crack it) when coasting to allow some steam to pass through the passages and exhaust in the normal way. The anti-vacuum valves may be mounted on the steam chests or singly or in pairs on the smokebox when they are connected to the saturated side of the [superheater header](#).

ARTICULATED LOCOMOTIVE

A locomotive where two engines (sets of cylinders, valve gear and wheels) were provided under the same frame but pivoted to allow transition through curves in spite of the long wheelbase. [Garratt](#) and [Mallet](#) were two types of articulated locomotives. Much favoured in Africa, India and the US but not common in Europe and the UK. Some locomotives built to Fairlie's patent also had two engines but not all were articulated.

ASHPAN

The light steel receptacle under the locomotive grate into which ash from the fire falls. It is usually fitted with dampers to adjust the airflow through the fire. Some ashpans were provided with water sprays to reduce dust when the fire was being cleaned.

ATLANTIC TYPE LOCOMOTIVE

Name given to the 4-4-2 type of locomotive, originally derived either from the locomotives of the Philadelphia Railroad which ran between Camden and Atlantic City NJ or from the group of this type built for the Atlantic Coast Railroad. The type was first introduced in the US in 1888 for the Lehigh Valley RR and in UK on the GNR in 1898 to a design by H.A. Ivatt.

[Return to top of page](#)

[To Home Page](#)

B

BALTIC TYPE LOCOMOTIVE

A locomotive with a 4-6-4 wheel arrangement. Referred to in the US as the Hudson type.

BAKER VALVE GEAR

A type of valve gear similar to [Walschaerts](#) but with less moving parts. It was popular in the US but was rarely if ever tried in Europe.

BANJO

The UK locomotive driver's nickname for certain types of [vacuum brake](#) valve handle in the cab, from its shape. Also used on some UK railways to denote a disc type ground signal. The name was also used to describe the dome cover on certain LNER locomotives on account of its shape.

BANKER

Nothing to do with money. See Banking Locomotive.

BANKING LOCOMOTIVE

A locomotive used to assist trains over a section of line incorporating a long or steep 'bank' or grade. Many banks had permanent allocations of 'banking engines' or 'bankers', which were attached to the rear of heavy trains which stopped specially to pick them up. At the end of the section where assistance was required, the banking engine

would drop off without stopping the train and later return to the bottom of the bank to assist another train. In US known as 'helpers'.

BAR FRAME

Type of locomotive frame almost universal in the US but rare in the UK. It originated in the UK in 1830 when it appeared on an 0-4-0 locomotive named Liverpool built by Edward Bury which was sold to the Petersburg Railway in 1833.

Bar frames were constructed of steel bars of about 4 inches square section. They were first used in US locomotive construction in the early 1840s.

BELL, LOCOMOTIVE

Locomotives in the US are required to carry a bell which is sounded as a warning when the train is moving within station limits. On many locomotives, these are automatically operated. The bell was first required by a law passed in the State of Massachusetts in 1835. Not used in the UK where, unlike many other countries, railways are fenced.

BELPAIRE BOILER

A design of [boiler](#) first developed by Alfred Belpaire, a Belgian locomotive engineer, in 1860, with an improved design in appearing in 1864. This later design consisted of a [firebox](#) with a flat top which allowed the use of vertical and horizontal [stays](#). The type first appeared in the UK in 1891 and was standardised on the Great Western Railway from the early 1900s. It was still in use for new locomotives during the 1950s.

BIG END

The crank pin end of the [connecting rod](#), where it is larger than the crosshead end because the stresses are higher at that end.

BIGHOLE

US slang term for emergency brake application, arising from the use of the brake valve to create a 'big hole' in the brake pipe, thereby venting it to atmosphere and thus causing the emergency application. Example: "I bigholed her and we just barely stopped before the switch." See more information in our [Brakes Page](#).

BISSEL TRUCK

A two-wheeled truck designed to allow radial movement, where the pivot point was in rear of the axle. Usually fitted at the leading end of a locomotive. It first appeared in the US in 1858.

BLAST PIPE

The pipe which carries the exhaust steam from the cylinders to the centre of the [smokebox](#). It is positioned below the [chimney](#) so as to allow the exhaust steam to escape directly and create the maximum vacuum possible. In this way the draught drawn through the [boiler tubes](#) and fire is maximised.

The use of the exhaust steam to assist with draughting was an early feature of locomotive design and it was usual to pipe the two cylinder exhausts separately into the chimney. The introduction of joining the exhausts into a central blast pipe below the chimney orifice came in 1827 and was gradually adopted from that time.

BLAST PIPE, VARIABLE

A variable blast pipe was introduced in 1839. It consisted of a cone fitted inside the blast pipe which was operated from a lever in the cab. Various manual systems were tried during the mid and late 19th century but they all fell out of fashion until the GWR introduced an automatically operated variable blast pipe system on its later locomotives. This was known as a 'jumper'.

BLINKERS

UK railway slang for smoke deflectors.

BLOW-BACK

The forcing of flames and smoke from the fire through the [fire hole](#) into the cab of a locomotive due to the draught through the [tubes](#) being reversed. It can occur when the [regulator](#) is closed while the locomotive is moving and is normally prevented by the use of the [blower](#). A blow-back can be very dangerous to the crew and there have been fatalities in the past as a result of blow-backs.

BLOW OFF COCK

A cock provided on a locomotive boiler, normally at the lowest point to allow it to be drained.

BLOWDOWN VALVE, CONTINUOUS

A valve provided to prevent priming in locomotive boilers. It is normally fitted on the firebox backplate near the water level of the boiler and used to remove a small amount of water at that level to reduce the scum formed as a result of boiling water chemically treated or softened to reduce scale. The continuous blowdown valve operates

automatically when either exhaust steam is available or, in some locomotives, when steam is detected in either injector delivery pipe. The process helped to reduce boiler washouts from weekly to monthly but it was disliked by the permanent way engineer because of the chemicals thrown onto the ballast.

BLOWDOWN VALVE, MANUAL

Some locomotives were fitted with a manually operated blowdown valve positioned in the centre of the firebox [throat plate](#) just above the [foundation ring](#). This valve was controlled from a lever in the cab and was used to discharge sludge which collects at the bottom of the boiler and foundation ring.

BLOWER

A means of providing a draught for the fire when no exhaust is available. A pipe takes [live steam](#) to a 'blower ring' usually fitted to the top of the [blast pipe](#) or the base of the chimney. The blower is used to maintain a draught on the fire. It is controlled by the driver, who will open a valve in the cab to allow live steam from the boiler to escape into the chimney whenever there is no exhaust steam from the cylinders to provide the draught.

The draught from the blower keeps the gases from the fire flowing through the [tubes](#) to the [smokebox](#) and prevents the possibility of a reversal of the flow with the resultant [blow back](#) of fire into the cab.

BOGIE LOCOMOTIVE

A steam locomotive with a 4-wheeled truck (or bogie) provided as part of the wheel arrangement.

BOILER

The enclosure on a locomotive where steam is produced. The boiler must be filled with water almost to the top. When the water boils, the steam it generates forms in the space between the top of the water and the top of the boiler. When enough steam collects, the pressure begins to build up until it reaches a useful working level. It will continue to build up until the maximum pressure is reached. This can be anything between 150 pounds per square inch (psi) and 300 psi, depending on the age and type of locomotive. To get a locomotive boiler up to working pressure from cold takes several hours.

The water in the boiler is heated by fire. The fire is placed in the [firebox](#) at the rear end of the boiler and the hot gases generated pass through hollow tubes (made of brass,

steel or copper) running the length of the boiler. "Tube plates", provided with a large number of holes to take the tubes, were fitted at the ends to seal off the boiler and to provide mounting plates for the tubes. At the front end of the boiler the hot gases escaped from the tubes into the "smokebox" and then upward to atmosphere through a "chimney" or "stack" as the Americans call it. At the rear, the tube plate formed the front of the inner firebox and is, in UK practice, made of copper, instead of the steel used for the front tube plate.

The traditional form of boiler was the same diameter throughout its length and was known as the parallel boiler. A later type which became popular was the tapered boiler, which was narrower at the front than the rear. This allowed more of the water to be at the rear where the greater heat from the firebox was available.

To reduce heat loss boilers are insulated and then covered with a thin steel sheathing. For many years, the insulating material was wood and then asbestos. In recent years various forms of natural or man-made insulating materials have been used.

BOILER BARREL

The main part of the locomotive boiler between the smokebox and the firebox.

BOILER CERTIFICATE

A formal notification verifying that a boiler is fit for use. Boilers are potentially dangerous and they are required by law to have regular inspections by qualified inspectors who must issue certificates to show that they are safe to operate. In the UK, a boiler certificate is issued for seven years, after which time the boiler must be overhauled and re-certificated. In practice, for use on preserved railways, ten years is possible with an insurance inspection after 5 years to confirm the extension to 10 years. In South Africa it is nine years. In the US it varies from state to state.

BOILER CLOTHING

See boiler insulation.

BOILER CONSTRUCTION

Locomotive boilers were originally made of wrought iron but a steel boiler was first used in the UK by George Tosh of the Maryport and Carlisle Railway in 1862. A locomotive with a steel boiler had appeared in Canada two years before in 1860 and it gradually became general around the world from that time although wrought iron was still being used in the UK on some railways 30 years later.

The steel used in boiler construction has to be of good quality. The stresses required of even a small boiler are considerable and the results of a weakness in design or construction could be fatal if a boiler explosion occurred. Leaks, although less serious, would cause poor steaming, with possible delays to trains and would cost money in repairs and lost availability.

It is essential that a boiler be manufactured to a precise circular form in section. This ensures an even distribution of stresses. The boiler plates are first bent by passing them through rollers and are then riveted together to form circular sections. Barrels up to 12 feet long are usually made of two sections, longer ones being of three sections.

The rolled plate of each section is butt jointed to give the circular form required and special 'butt strips' added above and below the joint. The whole seam is then riveted up so that each section or 'ring' has one longitudinal joint. It is important that a true circle is formed by each boiler ring so that, when steamed, the boiler rivets are not put under excessive stress. Boiler rings were also secured to each other by riveting lap joints.

In the later years of locomotive development, some parts of and even complete boilers were welded. An all-welded boiler was fitted in the US to a Delaware & Hudson 2-8-0 locomotive in 1934 but it had to undergo several years of regular use before it was accepted as safe by the Interstate Commerce Commission. In Britain, the Southern Railway 4-6-2 locomotives designed by O.V. Bullied and introduced in 1941 had welded boiler seams and parts of the firebox were also welded.

Adding the firebox was a complicated operation. The 'throat plate', which joined the lower part of the firebox to the boiler barrel was a particularly awkward shape requiring a hydraulic press for its manufacture. The remaining parts of the firebox have also to be specially formed and then assembled to provide the inner and outer fireboxes. The assembly involves screwing into position a large number of staybolts or stays, which hold the inner firebox in the correct position inside the outer firebox. Later locomotive designs could have over a thousand stays in the firebox.

Before inserting the tubes, the riveted joints are caulked to ensure that the boiler is steam tight. The tubes are expanded into position in the tube plates.

BOILER EXPANSION

The natural expansion of the boiler as it heats is allowed for in its design. It is normally secured to the locomotive's frame at the smokebox end and only rests on the frame at the firebox end so that it may slide freely when it expands.

BOILER INSULATION

At first, locomotive boilers were usually insulated with wood battens secured by hoops and varnished. Fireboxes were left bare at first but, from 1839 some were covered, either over the lower part or totally. A layer of felt was sometimes added under the wood but this got wet in the rain and, from 1847 there was a gradual introduction of sheet iron covering in place of wood. From about 1900 asbestos was used and this remained until its use was rendered illegal in most countries and various forms of wool waste or felt were again adopted.

BOILER MOUNTINGS

Generic term for attachments to locomotive boilers e.g. safety valves, dome, chimney, clacks, whistle etc.

BOILER PRESSURE

See Pressure, Working.

BOILER TUBES

See [Tubes, Boiler](#).

BOILER TUBE CLEANING (on the move)

A technique employed on oil-burning locomotives. When running, sand is allowed to be sucked into the firebox by the draught (via the fire hole, often called a "fire door" in the US), which will then be pulled into the flues by the draught, knocking the soot loose from the tubes. This is necessary since the oil used for steam locomotives produces copious amounts of this deposit, and since the deposit from burning acts to insulate the tubes, it inhibits steaming. A similar system was once tried on some coal burning LMS locomotives in the UK.

BOOSTER

A secondary steam engine provided on a locomotive's trailing axle or [tender](#) to assist with train starting. As a result of the fact that a boiler's maximum capacity for steam generation is normally only tested when a train is running at top speed or working up a long steep gradient, extra steam is available at starting. To assist with starting a heavy train, some locomotives were provided with boosters.

[Tender](#) boosters first appeared in the US in 1922 on the Delaware & Hudson RR and they became popular across the US. Boosters were tried in the following year in the UK on

the Great Northern Railway and appeared on a number of engines over the following few years. They were not considered successful. See also [Steam Tenders](#).

BOSS

The central, solid part of a railway wheel, which is pressed onto the axle.

BOXPOK

Disc driving wheels common on US locomotives towards the end of the steam era. In addition to being easier to manufacture and having a longer life than spoked drivers, they were much easier to balance, a necessity with the standard two-cylinder arrangement of the vast majority of US locos.

BRAKE BLOCK

The friction material which is pressed against the tyre of the wheel during braking. Early brake blocks were wooden and later became cast iron as train speeds and weights increased. More recently, various types of composition materials have been introduced to reduce the weight and wear rates of the older types.

BRAKE RIGGING

The rods and levers which connect the brake cylinder to the brake blocks on each wheel. See also our [Brakes Page](#).

BRAKE SHOE

Synonymous with [brake block](#).

BRAKES, TYPES OF

Steam locomotives originally had no brakes, they were braked from a hand operated tread brake on the tender. In 1833, Stephenson fitted a steam-operated brake to his Patentee locomotive design, but this was not widely adopted. Once [continuous brakes](#) were introduced from the mid-1870s, locomotives were also provided with brakes.

For detailed information on train brakes, see our [Brakes Page](#).

BRASSES

UK railway slang for the bearings on locomotives such as the [big ends](#) etc.

BRICK ARCH

Said to have been first tried in 1841 by an engineer named Hall as a way of obtaining smokeless combustion of coal. Previously, engines had burned coke or (in the US) wood. It is also said to have been used on the Scottish North Eastern Railway by Thomas Yarrow in about 1857. It was patented in the US in 1857. It finally became universally accepted in Britain after its introduction on the Midland Railway, together with the firehole deflector plate in 1859.

The brick arch is located in the [firebox](#) over the grate and is attached to the forward firebox wall and the side walls. Its purpose is to deflect the gases rising from the grate towards the back of the firebox so as to keep them over the heat source as long as possible before they pass up into the boiler tubes. This ensures that more complete combustion takes place and that as little unburned smoke as possible escapes through the chimney.

BUNKER

The enclosure built at the rear of tank engines in place of a tender which carries coal and sometimes water.

[Return to top of page](#)

[To Home Page](#)

C

CAB, ALL WEATHER

Popular component of colder-climate locomotive operations, where the locomotive cab was almost totally enclosed. Canada and Russia had many examples.

CAB FORWARD LOCOMOTIVE

A rare type, where the traditional cab end and smokebox end was reversed, with the tender located at the smokebox end. A type existed briefly in Italy (a 4-6-0 coal burner), but the more successful versions were the 4-8-8-2 oil-burning types used by the Southern Pacific Railroad in the US. This type afforded excellent forward vision for the driver and fireman (so much so that the driver could see the whole road without the fireman's aid) and put the exhaust behind the crew, clearing both vision and breathing (especially when travelling through tunnels).

CAMEL BACK LOCOMOTIVE

This unusual type was common on a lot of northeastern US railroads. The driver's cab was wrapped around the mid-section of the boiler, affording him decent forward vision

but cutting off communication with the fireman. The Camelback approach (a.k.a. "Mother Hubbard") was used in conjunction with the first Wooten firebox-equipped locomotives. The fireman made do with a rudimentary shelter at the rear of the locomotive, sometimes needing two firemen to feed the large grate characteristic of a Wooten firebox.

CAPROTTI VALVE GEAR

A cam operated valve control gear invented in 1921 by Arturo Caprotti, an Italian engineer. It was first tried in the UK on an LNWR Claughton Class locomotive in 1926. Various other railways have tried the system but it was never widely adopted, even though there were some examples which showed a reduction of coal consumption of 20%.

CHIMNEY

The opening in the top of the smokebox through which the exhaust steam escapes. The design of the chimney and blast pipe (q.v.) is a crucial ingredient in ensuring a good draught through the tubes and fire. Known as the 'stack' in the US.

CINDER STRIP

A strip of angle iron fitted to the roof of a locomotive cab to reduce the influx of ash from the chimney when passing under a bridge or entering a tunnel.

CLACK VALVE

A non-return valve provided to allow water to be fed into the boiler against the pressure of the water inside. Sometimes the valve is mounted with the injector (q.v.), sometimes separately on the boiler side or top.

CLACKS

See 'Clack Valve'.

CLASP BRAKES

Brakes where the wheel is equipped with a block on each side of the wheel, as opposed to only one side. See our [Brakes Page](#) for more details.

CLINKER

Solid matter produced by a coal burning fire, especially under poor combustion conditions or with poor quality fuel. Clinker must be disposed of at regular intervals during its duty if a locomotive is to continue to produce sufficient steam to enable it to maintain a

reasonable rate of work. Sometimes this had to be done during a single trip where poor coal was used. South Africa is a particular example of this problem.

COAL

Coal replaced [coke](#) as the principle locomotive fuel in the UK upon the introduction of the [brick arch](#) and [firehole deflector plate](#) about 1860. It soon became obvious that some varieties of coal were better than others. The so-called UK hard steam coals from Durham, Northumberland and South Wales were considered better, with the South Wales coal being the best. These coals had a high carbon content and a volatile content below 14%. When burnt, little clinker was formed and a good flame was produced. Yorkshire coal was also used by some railways but it was not such high quality as the South Wales type.

Poor coal produces clinker and does not allow good draught. Coal size is also important, in that larger pieces needed to be broken down to about the size of a man's fist to allow the spread of even flame over the whole grate. Larger pieces would cause 'black spots' in the fire, a sure sign of lower temperatures and less effective combustion.

Coal burning locomotives were tried by Joseph Beattie in 1854 on the London & South Western Railway. He designed a double firebox and combustion chamber to this end. Various other devices were tried over the next few years in an attempt to improve combustion, including the use, by some engineers, of centrally divided fireboxes fitted with a [mid feather](#) to improve circulation.

COAL PUSHER

A steam powered device fitted to some larger UK locomotives on the LMSR which was mounted at the rear of the [tender](#) coal space and which assisted with the forward movement of coal towards the cab where it could be reached by the fireman. It was controlled from the cab and acted by oscillating and thus vibrating the coal forward. Ordinarily, the fireman would have to go onto the tender to reach any coal which had not shaken forward as a result of the motion of the locomotive.

COAL RAILS

Slatted extensions to [tender](#) sides to allow coal to be stacked higher on the tender.

COAL STAGE

A special track raised above the surrounding track level so that coal wagons can be raised to allow them to be discharged into locomotive tenders.

COKE

Early steam locomotives in the UK used coke as fuel, instead of coal, because of an early legal requirement that locomotives should 'consume their own smoke'. Coal produces smoke when burnt whereas coke burns almost smoke free. Coke is created by heating soft coal in an airtight oven. As it heats, the coal decomposes to give a hard, porous, greyish substance called coke, which contains almost 90% carbon. When it burns, coke produces intense, smokeless heat.

A by-product of coke manufacture is coal gas, which was widely used for industrial and domestic heating in the UK before the advent of natural gas from the North Sea. Coke was therefore a readily available fuel source for the railways.

It seems that coal replaced coke as the principal locomotive fuel after the introduction of the brick arch into locomotive fireboxes. This occurred in 1847, but general adoption of the brick arch seems to have come after 1860.

COLLECTING PIPE

A pipe for the collection of the steam from the top of the boiler, used on boilers where the [regulator valve](#) was not housed in a [dome](#). Some boilers were designed without domes, principally because it was thought that cutting a hole in the top of the boiler would lead to weakening the structure. In locomotives of this type, steam was collected in a pipe positioned at the top of the boiler barrel. The collecting pipe was perforated on the top side to allow the steam inside so that it could pass to the [regulator valve](#). In superheated locomotives, it was common to position the regulator valve in the superheater header instead of in a dome.

COLLOIDIAL FUEL

A semi liquid mixture of powdered coal and oil sprayed into the locomotive [firebox](#) with the assistance of steam pressure. It was controlled by the fireman using valves in the cab.

COMPOUND ENGINE

A system applied to steam engines whereby the steam was used twice, once in 'high pressure cylinders' at the pressure developed in the boiler and afterwards in 'low pressure cylinders' using the steam exhausted from the high pressure cylinders. The system was first tried on a locomotive of the UK Eastern Counties Railway in 1850 and later became popular for many locomotive designs world-wide. The Midland Railway was the chief exponent in the UK. It was sometimes referred to as 'continuous expansion'.

COMPOUNDING

The use of steam twice, once in a high-pressure cylinder and then in a low-pressure cylinder. See [Compound Engine](#).

CONED BOILER

See [Tapered Boiler](#).

CONJUGATED VALVE GEAR

The system for operating the valves of a third cylinder by means of levers driven by the motion of the [valve gear](#) of the other two cylinders. Its most famous version in the UK was that used by H. N. Gresley on his 3-cylinder locomotives for the Great Northern and LNE Railways from 1922 and adopted by some other railways world wide. Although it reduced the number of moving parts, its most serious disadvantage was the whip effect produced by the levers which caused excessive wear.

CONNECTING ROD

The steel arm which connects the [piston rod](#) with the crank on the driving wheel or driving axle. It is used to convert the forward and aft motion of the piston into the rotating motion of the axle. It is designed in a tapered form and has a 'little end', where it is connected to the crosshead on the piston rod, and a 'big end' where it is connected to the crank arm. The tapering is to allow for the greater stresses experienced at the crank end.

CONSOLIDATION TYPE LOCOMOTIVE

A locomotive with a 2-8-0 wheel arrangement said to have been named after the merging of the Lehigh & Mahanoy RR and the Lehigh Valley RR in 1865.

CONTINUOUS BRAKE

Generic term for a train brake which provides for control of the brake on every vehicle and is automatic to emergency stop in the case of loss of control. In most countries it is a legal requirement for passenger trains. Some freight trains do not always have all vehicles fitted with brakes. In the UK the two types of continuous brakes used were the vacuum brake and the air brake. See also in our [Brakes Page](#).

CORK

Used as a stopper for the filling points of lubricating reservoirs on locomotives.

CORRIDOR TENDER

A locomotive tender designed by Sir Nigel Gresley for the non-stop London - Edinburgh service in 1928 and fitted to some of his class A4 pacific locomotives. It allowed the locomotive crew to be changed en route without stopping the train. The changeover took place just north of York. It allowed the longest regular non-stop steam locomotive trip anywhere in the world.

COUNTER BALANCE

A system for overcoming the forces induced by a steam engine in converting the sliding motion into rotating motion. The most obvious counter balancing can be seen on the driving wheels where segments of steel, containing lead cores, are attached to the wheels to act as balance weights to reduce the [hammer blow](#) caused by the crank action. Additional balance weight is provided on the motion to oppose the weights of [cranks](#) and levers.

COUPLING ROD

Steel rod which connects the [crank](#) on the locomotive's main driving wheel to cranks provided on the additional driving wheels.

CRANK

A crank is a fixed arm attached at 90 degrees to a rotating axis so that forward and aft motion can be converted to rotating motion and vice versa. For the outside mounted cylinders of a steam locomotive so fitted, the means by which the horizontal motion of the piston is converted into rotary motion to drive the wheels.

CRANK AXLE

An axle on a locomotive where cylinders are mounted inside the frames and the drive of the pistons is transmitted to the wheels by means of [cranks](#) built into the axle to accommodate the motion of the [connecting rods](#). The first locomotive with a cranked axle was "Novelty", built in 1830 for the Rainhill locomotive trials by John Braithwaite. Inside cylinders became a standard design for many locomotives in the UK and remained so until the 1920s.

CRANK, RETURN

See [Return Crank](#).

CROSSHEAD

The steel block which carries the bearing joining the [piston rod](#) and the little end of the [connecting rod](#). The crosshead is fitted between two [slidebars](#) so as to maintain the alignment of the piston rod with the centre line of the cylinder.

CROWN

The roof of the inner firebox shell. It is secured to the outer firebox shell by crown stays. See also [Stays](#) and [Firebox](#).

CUT OFF

In steam engine operation, the point at which the valve closes the steam port to prevent more steam entering the [cylinder](#), i.e. the end of the admission cycle. Beyond this point, the natural expansion of the steam continues the push of the piston started by the admission of steam. The cut off point can be varied by the driver adjusting the position of the [reverser](#) in the cab.

Cut off is referred to as a percentage of the piston stroke. It will usually vary between about 15% and 75% of the stroke. When a locomotive is starting, maximum power is required so steam will be admitted into the cylinder for as long as possible, or about 75% of the piston stroke. The engine is therefore working at 75% cut off. Once the train is moving, the cut off is adjusted in steps (sometimes called notches) until it has reached the required speed on level track. By this time, the amount of steam admitted into the cylinder for each stroke has been reduced and the reverser adjusted so that the engine may then be running at 15% cut off.

CYLINDER

The heart of the main power conversion system of the steam engine. A locomotive has at least two cylinders, mounted at the leading end so as to be clear of the driving wheels. Next to each cylinder is a valve which controls the flow of steam into and out of it. Normally, a cylinder and its valve chest are cast in a single block which is carried on one of the side frames.

A locomotive may have two, three or four cylinders depending on the design and age, but there will always be at least two. On some two-cylinder locomotives, the cylinders are hung between the frames ("inside cylinder locomotives") and drive the wheels through a [cranked axle](#). With this design the cylinders and valve gear are largely hidden from the outside and are difficult to see unless you know where to look. Locomotives with three or four cylinders will have two outside and the others inside the frames.

Much importance is laid on the size of cylinders in relation to the boiler size and pressure and the amount of work the locomotive is required to do. See also [Cylinder Operation](#).

CYLINDER COCKS

The use of steam in locomotives causes much condensation which appears as water in pipes, valves and [cylinders](#). Water can reduce the efficiency of the steam and could damage cylinders where steam is admitted on top of water which has collected in them. To eliminate the water, cylinders are fitted with small exhaust ports called cylinder cocks so that the water can be expelled under steam pressure.

The cylinder cocks should normally be left open when a locomotive is standing. They should remain open as the locomotive is started so that, when steam is admitted into the cylinders the water is blown out. Once the locomotive is moving and the cylinders are warmed up, the cocks can be closed and full pressure is available. There are normally three cocks per cylinder linked together. They are controlled from the cab and can be steam operated or mechanically operated by a lever.

CYLINDER OPERATION

When steam is released into a cylinder, it expands into the space available. If a piston is placed inside the cylinder, the pressure of the steam and its expansion will push on the piston. When the piston reaches the end of its stroke, steam is admitted to the cylinder on the other side of the piston. This pushes the piston back. The steam used for the initial stroke is now pushed out of the cylinder as the piston returns and is exhausted into the smokebox, where it escapes through the chimney into atmosphere. The puffs of exhaust steam escaping into the air make up the characteristic sound of the steam locomotive.

In detail, the cycle is as follows. Before the piston starts to move, steam is admitted into the space between the cylinder end and the piston face to build up pressure. This is known as 'lead'. Once a certain amount of steam is admitted into the cylinder and the piston starts to move, the supply of steam is cut off. Now, natural expansion of the steam takes place and the piston pushes as far as it can go. For the last 25% or so of its stroke, the exhaust is opened and steam starts to escape. By the time the piston starts its return stroke, the same process is being repeated at the other end of the cylinder.

Ahead of the piston during its return stroke, steam from the previous cycle is exhausted until it is 75% along its stroke, when the port is closed and the remaining steam is compressed up to perhaps 30% of the normal admission pressure. At this point the lead position is reached again and the whole cycle is repeated.

[Return to top of page](#)

[To Home Page](#)

D

DAMPERS

Adjustable doors fitted to the [ashpan](#) of a locomotive to enable the flow of air through the fire to be adjusted. Dampers are controlled from the cab by a lever.

It was usual for most tender locomotives to have front dampers only but the GWR had rear dampers as well. It was usual for drivers on that railway to run with the rear dampers only open and for them to open the front dampers only when required for harder working of the fire.

DART

The long, straight fire iron used by a [fireman](#) to clean the locomotive fire and remove [clinker](#).

DE GLEHN

The name given to a French system of [compounding](#) used at the turn of the century, which involved the use of two high pressure cylinders driving the rear wheelset and two low pressure cylinders driving the front wheelset of a 4-coupled locomotive. Four sets of [Walschaerts valve gear](#) were used to give independent control of the two sets of cylinders. Three locomotives of this type were tried on the Great Western railway from 1903 but they were not considered much better than the line's most modern engines and were not universally adopted.

DEAD LOCOMOTIVE

One which is cold and usually has its [driving wheels](#) disconnected from the cylinders.

DE-SANDER

A steam pipe positioned on some later designed steam locomotives to remove sand which has been applied to the rail head. It was done because sand tends to cause poor train detection on lines where track circuits are used as part of the signalling system.

DETROIT SIGHT FEED LUBRICATOR

A type of locomotive lubricator - see Displacement Lubricator.

DIE BLOCK

In Stephenson's and Walschaerts and similar 'link' type [valve gears](#), the block through which the radius rod (q.v.) moves and which itself slides up and down the [expansion link](#) according to the position of the reversing lever.

DISPLACEMENT LUBRICATOR

An oil lubricator for steam locomotives first introduced in the UK in 1857 by John Ramsbottom (of safety valve fame). It operates by steam condensing to produce water which is fed into a chamber and which gradually displaces oil from the top of the chamber, allowing it to rise and overflow into delivery pipes. Often positioned in the cab where the feed glasses can be seen.

DOME

A boiler fitting (of dome shape) resting on top of the boiler and used to house (most commonly) [regulator valves](#), [safety valves](#), or sand. The need for the dome first arose in the early days of locomotive design because the bubbling water near the top of the boiler often got carried over into the steam pipe leading to the cylinders -see also [Priming](#). Cylinders were often damaged as a result. To overcome the problem, a dome was placed on the boiler (or firebox) to collect steam and divert it to the regulator valve.

Some locomotive engineers preferred domeless boilers, believing that by requiring a large hole, they weakened the structure of the boiler itself.

DRAWBAR HORSEPOWER

See 'horsepower'.

DRIVING WHEELS

The large wheels connected to the steam engine pistons which therefore drive the locomotive.

DROP GRATE

First introduced by Edward Bury in 1852 to allow easier fire cleaning and removal, the drop grate comes in a number of varieties. Usually designed as a part of the grate which can be opened on hinges and through which the clinker or the whole fire can be pushed if required.

[Return to top of page](#)

[To Home Page](#)

E

ECCENTRIC

In steam engine technology, part of the [valve gear](#) used by some designs to give motion to the valve. It may best be described as an auxiliary crank.

It is essential to ensure that the valve events occur in the correct sequence in relation to the movement of the piston inside the cylinder. The valve spindle is therefore driven off the motion of the piston by connecting it through links and levers to the connecting rod, crank or driving axle, depending on the design of the valve gear.

Where inside cylinders are used, it is usual to derive the valve motion off eccentrics fitted to the driving axle. The eccentric consists of a circular disc, called a sheave, fitted to the axle so that its centre is offset from that of the axle. An eccentric rod is attached to the sheave by means of a strap which allows the sheave to rotate within the strap. When the axle rotates, the eccentric produces a fore and aft motion at the leading end of the eccentric rod. This, in conjunction with the [expansion link](#) and the setting of the [reverser](#), is used to give motion to the valve spindle.

EJECTOR

A steam operated device for creating a vacuum on trains equipped with the [vacuum brake](#). Normally there are two ejectors, a 'large ejector' and a 'small ejector'. The latter is usually left on while the train is running in order to continuously evacuate the brake pipe at a low rate to overcome small leaks in the pipework. The large ejector creates a rapid evacuation of the brake pipe to effect a brake release. It is closed off once the brakes are released.

ENGINE, STEAM

The portion of a steam railway locomotive which consists of the cylinders, valves, valve gear and connecting rods. Put another way, it is that portion of the locomotive which provides the drive. The equivalent in a road vehicle would be the engine and gearbox. The word 'engine' is often misused to mean the whole locomotive.

EXHAUST STEAM

The steam which escapes from the cylinders after the admission and expansion phases (see cylinder operation) have taken place, i.e. after the steam has completed its work. Exhaust steam is used for a number of purposes after it has left the cylinders, e.g. to operate injectors, ejectors etc.

EXHAUST STEAM INJECTORS

First introduced in the UK about 1876. The use of exhaust steam to assist the work of [injectors](#) allowed some fuel savings over the pure [live steam injector](#). BR class H, J, H/J and K types of exhaust steam injectors are all basically similar. Two controls are provided in the cab, a water regulator and a steam valve. The water regulator handle has a "sector" to denote the position of the valve. The valve itself is part of the injector body mounted outside the cab - often under it.

The steam valve is mounted on the boiler backplate and its housing includes the water delivery pipe from the injector, which passes through the backplate, over the firebox crown and down the boiler to deposit the feed water towards the front. Saturated steam is taken from the dome or the [steam fountain](#) to provide the live steam supply to the steam cone when the injector is turned on.

Exhaust steam for the injector is supplied from the cylinder exhaust. Steam from this source is only at about 10 psi but it is combined with live steam to drive the water into the boiler against its pressure. An additional supply of superheated steam from the downstream side of the regulator is passed from the smokebox to the injector to allow closing of the regulator to be detected. The absence of superheated steam causes an automatic shuttle valve to close in the injector. This prevents the saturated steam supply from reaching the exhaust valve control and this valve closes. Since the closing of the [regulator](#) will mean no exhaust steam is available, the injector will work entirely on the saturated steam available.

EXPANSION

A given amount of steam will naturally attempt to expand into a space. If that space is a cylinder occupied by a piston, the steam will push the piston until it can expand no further. In a steam engine, the steam is admitted into the cylinder for a time until the supply is cut off. The admission of steam pushes the piston until the admission is cut off, after which time the steam naturally expands and continues to push the piston. The two phases are known as 'admission' and 'expansion'. The point at which admission stops and expansion commences is known as [cut off](#).

EXPANSION LINK

A curved, slotted lever provided in various designs of valve gear to allow adjustment of the valve events relative to the position of the reverser, hence its name referring to the period of steam expansion. It carries the die block which is used to assist the setting of

forward and reverse and the various [cut off](#) positions in between and provides a link between the [eccentrics](#) and the valve rod.

[Return to top of page](#)

[To Home Page](#)

F

FAIRLIE LOCOMOTIVE

An articulated type of locomotive designed by Robert F Fairlie in 1865. The design was popular on narrow gauge lines. The frame was mounted on to one or two engine units which could move independently. The engine units could have leading and trailing trucks. A double Fairlie had two engine units, a single Fairlie one, the other being replaced by a bogie. The double Fairlie appeared to have two boilers but this was not the case. They had a single boiler with a firebox and cab in the middle and a smokebox at each end. The cab was in the middle, and the boiler barrel ran right through it, with the driver on one side and the fireman on the other. The driver on a double Fairlie controlled the water supply to the boiler as well as driving, leaving the fireman to look after the fire. This saved space on the fireman's side of the cab. Over 500 Fairlies were built in the USA including, in 1871 the Mason-Fairlie locomotive. They were also used in Russia, India, Australia, and New Zealand. The Fell locomotives used in New Zealand were Fairlies.

FEED PUMP

The means of getting fresh water into the boiler from the tank before injectors became common from the 1860s. Pumps could be worked off an extension of the piston rod, the engine [crosshead](#) or from an [eccentric](#) on an axle. Some designers added a steam driven pump or donkey engine to allow water to be fed to the boiler when the locomotive was stationary.

FEED WATER HEATING

Various means of pre-heating the water supplied to the boiler were tried over the 125 years of steam locomotive development. In 1854 Joseph Beattie of the London & South Western Railway introduced a steam heated water supply system on his new locomotives and in 1862, Stephenson & Co. built a locomotive with a tank under the footplate which was used to heat the feed water using live steam. Sometimes, tender water heating was used.

The introduction of injectors provided some pre-heating of feed water in themselves but they would not work if the water had already been heated to above 120 F in the tender or before reaching the injector.

In later years some locomotives used feed water heating and had to have steam driven feed pumps. The French ACFI system was a well-known example.

FELL SYSTEM

A system which allows locomotives to climb gradients at or over the limit of adhesion by means of a central third rail. The locomotives are equipped with a second set of cylinders driving wheels parallel to the ground and forced against the centre rail by spring or screw pressure. The Fell system differs from other mountain railway systems in that it depends on friction alone; the centre rail is a plain section unlike the Abt and other systems where the rail is toothed to correspond with toothed wheels on the locomotive.

FIRE HOLE

The opening in the rear wall of the [firebox](#) through which access to the fire is gained from the driver's cab. Its principal use is for shovelling coal onto the fire. It is normally kept closed and only opened for firing or cleaning the fire.

FIRE HOLE DEFLECTOR PLATE

An angled plate fitted inside the firebox over the fire hole to assist the flow of air over the fire so that the best gas heating rate is obtained. It works in conjunction with the [brick arch](#).

FIREBOX

The compartment at the rear of the boiler which houses the fire. The firebox is where the fuel, usually coal, but it can be wood or oil, is burnt to provide the heat to boil the water in the boiler. The firebox consists of two copper or steel enclosures, the outer firebox and the inner firebox. They are connected by 'stays', bolts which keep the inner box rigid within the outer box. Normally, the stays are threaded at each end and are screwed into the steel plates of the firebox. The ends are hammered down as a seal.

Copper fireboxes were the normal practice for UK railways but in the US, steel was the usual material. The steel firebox was first tried by Alexander Allan on the Scottish Central Railway in 1860.

Boiler water surrounds the firebox sides front and top to allow maximum benefit from the fire for heating. The two side areas are often referred to as "legs", as they take on this

appearance in cross section. The outer firebox is really an extension to the boiler. When the boiler is filled, water will enter the outer firebox legs and cover the roof or "crown" of the inner firebox. The boiler's tubes are connected to the front wall of the inner firebox so that the hot gases from the fire pass through them to the smokebox.

Inside the firebox a brick arch is positioned over the fire so that the heat from the fire is deflected towards the back of the firebox to ensure the hot gases are distributed towards the tubes more evenly. In their inspection, the lighting- up crew will check that the firebricks are secure and undamaged.

The two shells of the firebox are joined at the base by what is known as the 'foundation ring' or 'mud ring'. This name arises from the sludge which tends to collect there during the time between boiler [washouts](#), as it is the lowest point of the boiler where water reaches.

Firebox shape has developed over the years. To get the required grate area to heat a large boiler, older fireboxes tended to be long but narrow, as they had to rest between the locomotive's frames. This led to difficulties with manual firing, as the coal had to be thrown towards the rear in spite of a slope being provided. Later designs had the frames lowered at the firebox end to allow a wider firebox with a shorter grate. See also the [Belpaire](#) boiler.

FIREMAN

Second crew member for a locomotive responsible for the production of steam. This requires that he looks after fire upkeep and the maintenance of sufficient water in the boiler. He will also assist the driver with observation of the road, care of the locomotive, coupling and uncoupling etc.

FLANGE

The fundamental element of the wheel-on-rail guidance system. The inner edge of each wheel is shaped to a larger diameter than the wheel tread resting on the rail to act as a guide for the wheelset. The two flanges of the wheels on an axle guide the wheelset to follow the route of the track. A characteristic squealing sound can often be heard on sharp curves as the outer wheels' flanges slice along the inner edges of the rails.

FLANGELESS WHEELS

Common on many early locomotives to ease travel around curves. Also used on later designs such as 2-8-0 locomotives for the same purpose.

FOUNDATION RING

The base upon which the [firebox](#) is built. Originally circular, the foundation ring (also known as the 'mud ring') joins the outer and inner firebox shells and seals the water space around the inner firebox. The name mud ring arises from the sludge which forms at the base of the water space due to the collection there of impurities in the water.

FRAMES

Locomotive frames were generally of two types, plate or bar. In the UK plate frames became standard whilst in the US bar frames were standard.

In the UK during the 19th century, locomotives were built with inside frames, outside frames and double frames. The arrangements were tried by various designers offering various reasons for their choice. Double frames gave better stability and strength and it was the practice to provide two sets of bearings for the driving wheels and one set for coupled wheels. Double frames made locomotives heavier but, given the science of metallurgy in those days, they were preferred against single frames because the latter showed a tendency to fracture more readily. There were some who believed that with double frames, the risk of broken [crank axles](#) was reduced and, even if they did break, the risk of derailment was reduced. Eventually, improvements in the quality of the steel used and the need to reduce weight led to the universal introduction of inside frames by the end of the First World War.

During the construction of frames it was essential to ensure that they were square, as any deviation would result in the [cylinders](#), [valve motion](#) or [cranks](#) being out of line and thereby causing damage during running. Some locomotives used cast frame beds, particularly in the USA and by Beyer-Peacock where the engine frame was a single piece steel casting, thus guaranteeing the thing stayed square and true. The South African GM-AM locomotives also have cast beds.

FULL GEAR

The position of the [reverser](#) where the maximum [cut off](#) is selected to allow the maximum amount of steam into the cylinders. Usually used for starting, after which the cut off is reduced or shortened to allow more expansive working of the steam. A locomotive may be in 'full forward gear' or 'full reverse gear'.

FUSIBLE PLUG

In the UK it became common to provide a plug in the crown sheet of the firebox which had a lead core in order to protect the boiler against failure if the water level was allowed to become too low. If water failed to cover the crown of the firebox, the lead core of the fusible plug melted and steam and water would escape into the firebox to extinguish the

fire. Embarrassing for the crew, who were responsible for ensuring the safety of the boiler, but not fatal, as a boiler explosion could often be.

[Return to top of page](#)

[To Home Page](#)

G

GARRATT LOCOMOTIVE

A type of [articulated locomotive](#) designed by Herbert W Garratt and built by Beyer Peacock of Manchester for various railways world-wide. The first appeared in 1909. The Garratt design consists of the engine superstructure, including water and fuel, which is on a rigid frame supported at the ends by two large bogies carrying the engines. Both engine units are free to move and are not necessarily connected to each other. The Garratt is simple expansion, both engines being supplied with high pressure steam.. Various wheel arrangements were employed e.g. 2-4-0 - 0-4-2, 2-8-0 - 0-8-2 and 4-8-2 - 2-8-4. The advantage of the design was the large space available for the boiler and firebox and the high adhesive weight compared with axle load. They were principally used for heavy freight service and were popular in Africa.

GAUGES

Locomotives are provided with various gauges: boiler water level (2), boiler steam pressure, steam chest pressure (recent locomotives only), carriage warming pressure, vacuum or air brake pressure. Certain auxiliary equipment was also sometimes provided with gauges.

GRATE

The base of the [firebox](#) upon which the fire rests. It comprises a grill of firebars with gaps between them to allow air in to assist with the combustion process. See also [Drop Grate](#) and [Rocking Grate](#).

GRATE AREA

The statistic used to determine the fire capacity of a locomotive. Early locomotives had grate areas of about 6 sq. ft. The most recent UK designs approached 50 sq. ft and the largest US designs reached 150 sq. ft.

[Return to top of page](#)

[To Home Page](#)

H

HADFIELD STEAM REVERSER

A popular and common type of steam assisted [reverser](#) seen occasionally in the UK but popular on the larger types of locomotives in Africa and India.

HAMMER BLOW

The force exerted by the thrust of the [connecting rod](#) on the [crank](#) and transmitted to the rail with each revolution of the driving wheel. Rotating masses must be balanced but since this is only the wheels and the connecting rods, this is reasonably easily done by balance weights.

Reciprocating masses such as pistons, piston rods, etc are much more difficult to balance. They are balanced at the wheel centres and on the crank axle itself. In fact the design of the crank axle may be inherently self-balancing to some extent. It is not desirable to balance 100% of reciprocating mass because this would result in the load on wheels dynamically changing during rotation (and this is exactly what hammer blow is). It was common practice to balance 60% of reciprocating mass but this was found to cause hammer blow, so was reduced to 30% on two cylinder engines. The balance is spread unequally over all coupled wheels. Four-cylinder engines, because of their cycle, are self-balancing, so balance weights are not used. Once again, adding weights to them actually causes hammer blow. Engines must not be operated under power without connecting rods as the unbalanced forces can actually destroy the track. See [Wheel Balancing](#).

HEATING, TRAIN

Locomotive produced steam heating of passenger coaches, which first appeared in the US in 1881 and in the UK in 1884.

HEATING VALVE

A valve provided in the locomotive cab to allow steam to be supplied to the train heating pipe through a reducing valve. A pressure gauge was also provided.

HEATING SURFACE

The total of the area of the [firebox](#) walls and [boiler tubes](#) providing heating contact with boiler water and therefore the most important indication of steam production capability.

HORN BLOCKS

The brackets fitted to locomotive frames to act as guides for the axleboxes.

HORN PLATES

Plates fitted for strengthening purposes around the axle openings on locomotive frames.

HOPPER ASHPAN

A type of ashpan designed to collect ash which can be emptied directly from a drop grate.

HOT BOX

Excessive heating of a plain bearing axlebox due often to a loss of adequate lubrication and which required the locomotive to be stopped before severe damage and possible derailment occurred.

[Return to top of page](#)

[To Home Page](#)

I

INJECTORS

Locomotive boiler water feed apparatus. Water in the boiler is consumed as steam is generated and it is essential that the water is replaced quickly to allow steam production to be maintained and to prevent too low a water level causing a collapse of the [firebox crown](#).

Early locomotives were equipped with mechanical pumps operated by hand or driven off the [valve gear](#) or [eccentrics](#). Of course, these were only operational while the locomotive was moving and it became the practice to top up boilers of stationary locomotives by positioning the locomotive against a set of buffer stops, greasing the rails under the driving wheels and applying steam to drive the wheels. This got the water pump working and allowed the boiler to be replenished without moving the locomotive.

In 1858 a French engineer named Henri Giffard invented the injector, a steam powered system for replenishing locomotive boilers. In the US, Messrs William Sellers of Philadelphia started selling them in 1860, the first being applied to a Baldwin locomotive.

Early versions of injectors used live steam forced through a series of cones whilst mixed with water from the tender. The pressure of the steam forced the water into the boiler. The application of steam to the injector was controlled by a cock in the cab. Later versions of injectors used exhaust steam piped from the cylinder exhaust while the

engine was under power but used live steam at other times. The changeover was automatic. This system saved steam (and therefore running costs) and eventually became common around the world.

The principle of the injector is based on the fact that steam escaping from a nozzle has a greater velocity than that of a jet of water issuing under the same pressure from a boiler. If cold water is added to the jet of steam, it begins to condense and the velocity of the steam will increase sufficiently to overcome the pressure of water in the boiler. By this means, water can be introduced into a boiler against its internal pressure

Some injectors used a combination of [exhaust steam](#) and [live steam](#). A connection at the base of the [blast pipe](#) was run to the exhaust part of the injector where it heated the feed water before it passes to an auxiliary injector. The auxiliary injector used live steam to force the water to the boiler. This type was patented by JJC and RD Metcalfe in 1908 and was claimed to save up to 15% on fuel and water.

There was a type of injector, with features patented by J Gresham in 1884 and 1887, which was a "vertical restarting injector". Steam supply and feed water passed through the flange by which it was attached to the boiler. There was also a Davies and Metcalfe type patented in 1899 and 1907 which was designed to operate with feed water too hot for an ordinary injector.

Injectors are tricky instruments and require a degree of skill to "prime" them and get them working. This is normally the task of the fireman. Once the steam is turn on, the right balance of water being applied has to be found. This will only work if the steam and the water are at the correct pressure. A balance also has to be found between too little and too much water being in the boiler. Too little risks melting the [fusible plug](#), too much risks boiler water rising to reach the [regulator](#), known as "priming", and getting into the steam pipe leading to the cylinders.

[Return to top of page](#)

[To Home Page](#)

J

JIMMY

UK enginemens' slang for a steel bar unofficially fixed across the [blast pipe](#) in an effort to reduce the size of the orifice and therefore improve the steaming of a locomotive.

JOHNSON BAR

US term for the [reversing lever](#) in the locomotive cab.

JOURNAL

The housing in which the axle turns. A source of much trouble if not kept lubricated properly.

JOY VALVE GEAR

A valve gear designed by David Joy in 1879 and quite widely used over the next 30 years. It was simpler than other valve gears but required the provision of a hole for a link in the connecting rod which was found to be a source of weakness and eventually led to the demise of the type.

JUMPER

A form of automatic variable [blast pipe](#) designed by Churchward for use on his GWR locomotives. Under high pressure exhaust steam a ring at the top of the blast pipe lifted to allow a wider exhaust opening and thus reduced the risk of the excessive exhaust pressure [lifting the fire](#).

[Return to top of page](#)

[To Home Page](#)

K

KYLCHAP

Steam locomotive exhaust system designed jointly by Kyala and Andre Chapelon and named after them.

L

LAGGING

See Boiler Insulation.

LAP (1)

The amount, expressed as a fraction of an inch, by which the valve in mid position overlaps the cylinder steam ports. Valves provided with long lap required greater travel to operate effectively but this allowed a freer exhaust and more sharply defined stages in the cycle of valve events. Long lap valves were introduced on the Great Western Railway in 1908

following importation of the idea from the US but it was not until the 1930s that their value was properly understood by other UK railways.

LAP (2)

Name given to the position on the driver's brake valve which closes all air ports between the brake pipe and the brake valve itself. Used to hold the brake pipe pressure after a partial application has been made. See [Brakes Page](#).

LARGE TUBES

Tubes containing superheater elements. See [Tubes, Boiler](#).

LATERAL MOTION DRIVING AXLES

Employed on later locomotives in the US with eight or more coupled driving wheels. Depending on the road, it usually negated the need for blind (flangless) drivers since the driving axles could turn with curves using this system, albeit within a limited curve radius.

LEAD

The amount, expressed as a fraction of an inch, by which the steam port is open when the piston is static at the end of its forward or backward stroke. The effect is to allow steam to enter the clearance space between the cylinder end and piston face before movement of the piston takes place so ensuring maximum steam pressure at the start of the stroke.

LIFTING THE FIRE

Railway slang for the occurrence of the draught being so strong that hot coals are sucked from the fire bed, drawn through the [tubes](#) and thrown out of the chimney. Tended to occur when the locomotive is being worked hard or 'thrashed'.

LINK MOTION

See Link Valve Gear.

LINK VALVE GEAR

A form of valve motion designed by one William Howe at the Stephenson locomotive works in 1842 and thereafter fitted to all their locomotives and many others. The design removed the need for clutch operated eccentric shifts and eliminated the vulnerable forks

or 'gabs' of the older motion. It subsequently became known as the Stephenson Valve Gear. Later types of link motion included the Walschaerts valve gear.

LIVE STEAM

Steam supplied directly from the locomotive boiler and used for various devices such as the [blower](#), [ejectors](#), [injectors](#), whistle, electric generators (where fitted), steam brakes etc. In some cases, when available, exhaust steam is used for power as an additive or substitute for live steam, e.g. as in the case of injectors.

LIVE STEAM INJECTORS

The live steam injector was a relatively simple device consisting of a steam inlet pipe, a water inlet pipe, a delivery pipe and an overflow pipe plus three internal cones. Steam from the boiler was admitted into a narrowing steam cone which turned the pressure of the steam into velocity. Next, the steam was allowed to combine with the water, piped from the tender tank, in the also narrowing combining cone. The effect of combining the cold water and steam was to partially condense the steam and heat the water. The hot water and remaining steam propelled itself at high speed out of the combining cone and into the neck of the delivery cone. The delivery cone widened into the delivery pipe and allowed the conversion of the speed of the hot water into pressure sufficient to overcome the internal pressure in the boiler.

Live steam for the injector was supplied through a control valve in the cab. There was also a water control handle. Normally, locomotives were equipped with two injectors.

LONG BOILER LOCOMOTIVE

A type of locomotive patented by Stephenson in 1842 which was provided with a boiler longer than the usual 9 feet of the day. The objective was to reduce the heat reaching the smokebox in an attempt to reduce the rapid destruction of smokeboxes and chimneys which had occurred up to that time. By increasing the boiler length to 13 feet or more, the temperature was reduced by over 30% and the life of smokeboxes was considerably extended.

LUBRICATION

An essential part of steam locomotive operation, lubrication takes a variety of forms: Worsteds pads fed from an oil bath below the bearing, siphoning from trimmings fed from oil baths, [mechanical](#), [hydrostatic](#), oil atomised by steam, and grease.

[Return to top of page](#)

[To Home Page](#)

M

MALLET LOCOMOTIVE

Designed originally by Anatole Mallet in 1884, the design was a compound locomotive with two sets of engines on bogie frames. Later versions were simple expansion locomotives and were developed in the US to the largest locomotives ever built, the Union Pacific 4-8-8-4 'Big Boy' class. A Mallet has the boiler rigidly fixed to the rear engine unit. The front engine unit is articulated to the rear and the boiler unit is free to move over it. This can result in the boiler unit projecting outside the front engine unit on curves (Reed has a photograph of this in 'Loco Profiles')

The Mallet is, strictly speaking, a compound with a high-pressure engine and a low pressure engine using the exhaust steam from the high pressure unit, although simple-expansion versions were built towards the end of steam in the USA.

MANIFOLD, STEAM

The steam pipe in the cab which supplied all the cab control valves such as the whistle, [injectors](#), carriage heating, blower, sanding etc. Sometimes referred to as the 'steam fountain'. In the US it was known as the 'turret'.

MARS LIGHT

A special type of electric headlight mounted on some US locomotives which rotated and which could be changed from a white to a red light. The change to red was automatic upon an emergency brake application.

MECHANICAL LUBRICATOR

Oil distribution system activated by pump action provided by mechanical connections to the [valve gear](#) of a steam locomotive.

MECHANICAL STOKER

A system for feeding coal into the [firebox](#), removing the need for it to be done manually by the fireman. It was generally accepted that a grate area over 50 sq. ft. required mechanical firing as it was too large to be manually supplied. Mechanical stokers appeared in the US from 1905.

Most systems were steam powered and were controlled from the cab. Some consisted of a chain belt and some operated with a steam jet. The most successful was the

archemidian screw type which appeared from about 1918. In all cases, the coal had to be broken into small sizes to enable it to be used. In the UK, mechanical firing was not tried until after World War II and then only a few locomotives were fitted.

MID FEATHER

A partition introduced into some [firebox](#) designs to try to improve both water heating and heat generation from the fire. Various forms were tried during the mid- to late-19th century but the benefits were not considered sufficient compared with the expense of construction and maintenance.

MIKADO TYPE LOCOMOTIVE

A locomotive with a 2-8-2 wheel arrangement, the name being derived from a design built in the US and delivered to the Japanese railways in 1897.

MOGUL TYPE LOCOMOTIVE

A locomotive with a 2-6-0 wheel arrangement. The first proper version of this locomotive was built in 1858 in the US by Baldwin.

MOTION

Generic term for the piston rods, [connecting rods](#) and [valve gear](#) of a locomotive.

MOTION PLATE

A large bracket attached to the locomotive frame which is used to support parts of the [valve gear](#).

MOUNTAIN TYPE LOCOMOTIVE

A locomotive with a 4-8-2 wheel arrangement first introduced in the US in 1911 for the mountain section of the Chesapeake & Ohio RR.

MUD RING

See 'Foundation Ring'.

MULTI-TUBE BOILER

One of the principal design advances for the steam locomotive was the introduction of the multi-tubular boiler. It was suggested to George Stephenson by Henry Booth and was fitted to his Rocket locomotive of 1829. It also appeared in France at the same time

on a locomotive built by Marc Séguin. Before this, locomotives had [single flue boilers](#) or [return flue boilers](#).

The multi-tube boiler contained a number of hollow [tubes](#) which allowed the hot gases from the fire to pass through the boiler to the chimney at the other end. The distribution of the heating effect led to more efficient steam production and assisted with the forcing of a draught on the fire. Note that this was different from certain other applications of multi-tube boiler, e.g. marine, where the water passed through the tubes and the heat was applied to the outside of the tubes.

[Return to top of page](#)

[To Home Page](#)

N

NOTATION, WHEEL

See Wheel Arrangement.

NOTCHING UP

Slang term for moving the reverser to reduce the cut off of the engine as the need for power is reduced. 'Notching up' has also been adapted by diesel and electric locomotive drivers to mean increasing power. The term originated from the reversing lever quadrant which had notches cut into it to allow the lever to be latched in a particular position.

O

[Return to top of page](#)

[To Home Page](#)

P

PACIFIC TYPE LOCOMOTIVE

A locomotive with the 4-6-2 wheel arrangement. The first 4-6-2s were built by the Baldwin Locomotive Works in the US for the NZ Railways, hence the name.

PANNIER TANK

A tank locomotive design where the water tanks were mounted on either side of the boiler as for a normal tank loco. but were raised so as to be clear of the running plate.

The design was almost exclusively UK Great Western Railway. It reduced the height of the centre of gravity as opposed to a saddle tank but allowed more access to the working parts than ordinary side tanks. Some saddle tank locomotives were unstable at speed with full tanks.

PISTON ROD

The rod connecting the piston to the crosshead at the rear of the cylinder. The piston rod is kept parallel to the cylinder by the [slidebars](#) guiding the crosshead as it moves forward and back.

PISTON STROKE

See Stroke, Piston.

PISTON VALVE

The type of steam engine valve, circular in shape, designed to overcome the design defects of the [slide valve](#), specifically steam tightness and wear.

PLUG, FUSIBLE

See [Fusible Plug](#).

POP SAFETY VALVES

A [safety valve](#) designed to reduce the 'dribbling' of steam from a boiler at full pressure and thus reduce wastage. They were first used in the US about 1867 and in the UK about 1873.

POPPET VALVES

[Steam chest](#) valves opened and closed by cam action, in the same manner as in a road vehicle engine. Better timing was possible with such systems but it was difficult to get the variations in cut off required to gain maximum efficiency. Various poppet valve systems were tried over the years including the Caprotti, Franklin, Lentz (RC) and Reidinger.

PRAIRIE TYPE LOCOMOTIVE

A locomotive with a 2-6-2 wheel arrangement first introduced in 1885 and popular in the US mid-west.

PRESSURE, BOILER

Synonymous with working pressure. See Pressure, Working.

PRESSURE, WORKING

The pressure of steam permitted in a steam locomotive boiler above which the [safety valves](#) will blow off the excess. A good crew will attempt to work the locomotive without reaching this pressure as operation of the safety valves wastes steam.

Early boiler pressures were low. Stephenson's 'Locomotion' of 1825 had a pressure of 25 pounds per square inch (psi), while his 'Rocket' of 1829 had a pressure of 50 psi. Ten years later, boilers with 100 psi capability were being built. By the turn of the century pressures had reached 200 psi on some larger locomotives and rose to 300 psi on some of the largest US locomotives. 280 psi was the highest pressure used in the UK.

PRIMING

The siphoning of water from the boiler into the [steam pipe](#), caused by too high a water level or by certain chemicals used to treat hard water. If water gets into the steam pipe it will affect the performance of the [superheater](#) by reducing the ability of the steam to dry properly and, if it reaches the cylinders, it can damage them and the [motion](#). In extreme cases, cylinder ends have been blown out, valve gear bent and locomotives derailed by the carry over of water into the cylinders.

PUMPS, WATER

The means of supplying feed water to the boiler before the introduction of [injectors](#). See [Feed Pump](#) and [Feed Water Heating](#).

[Return to top of page](#)

[To Home Page](#)

Q

R

RADIAL AXLES

Axles designed to move laterally entering a curve in an effort to reduce the flange and rail wear incurred with rigid axles. The design was normally confined to the leading or trailing carrying axles of a locomotive. The idea was first tried successfully by W B Adams of the London & South Western Railway in 1863 and was subsequently taken up by FW Webb and others. The axle could be guided by either curved axleboxes, as in the original Adams design, or by a curved transverse frame as in Webb's design.

RADIUS ROD

A part of [Walschaerts valve gear](#) connecting the piston rod motion to the valve gear motion.

REGULATOR

Once the boiler has generated sufficient steam, it can be used for useful work. A valve fitted on top of the boiler and often housed in a [dome](#), is used by the driver to admit steam to the cylinders. The valve is called "the regulator" (known as the "throttle" in the US) and is opened and closed by means of a long shaft connected to a lever accessed from the driver's position in the locomotive cab.

The steam collected in the dome can be admitted, by use of the regulator, into a [steam pipe](#) which is connected to the cylinders. Some locomotives have [superheated steam](#) and in such cases the regulator may be located in the smokebox.

The regulator is controlled from the cab by a lever. UK practice is to mount the lever on the top centre of the firebox backplate so that it is moved clockwise or anticlockwise to open or close the [regulator valve](#). The shaft connecting the lever to the regulator valve passes through the boiler steam space.

An alternative form of regulator control has the operating rods mounted on the outside of the boiler (along the left or right side) and actuated by a forward and aft lever in the cab. This type was popular in the US but was used on many of the more modern locomotives in the UK. It should be noted that just because the operating rods are visible on one side of the boiler, it will not necessarily follow that the driving position is on that side. Some locomotives have the driving position on the other side with the regulator handle connected to the operating rods by a cross shaft. In some cases, regulator handles were provided on both sides of the cab.

REGULATOR VALVE

The main steam control of a locomotive. Various types of valve and various locations for it were to be seen during the history of the locomotive but it was normally at the top of the boiler where the steam was hottest and usually in a [dome](#). Some superheated locomotives had the regulator valve positioned in the superheater header in the smokebox. For details, see [Regulator](#).

RETURN CRANK

On outside mounted [Walschaerts valve gear](#), the small crank which works off the main crank to take the place of the [eccentric](#) used with inside mounted valve gear.

RETURN FLUE BOILER

A type of boiler used for some locomotives in the 1820s and 1830s where the [single flue](#) was turned back to provide double the heating surface for the water in the boiler. It required the chimney to be at the same end of the boiler as the fire. Superseded by the [multi-tube boiler](#).

REVERSER

The locomotive's forward and reverse control, which is also used to adjust [cut off](#) to vary the steam admission and expansion cycles in the cylinders.

The direction of movement for a locomotive is decided when starting by determining which direction each piston must move first. This is done by adjusting the position of the valve gear of each cylinder with a [reverser](#) so that the first admission of steam will force the piston in the right direction to achieve the desired direction of wheel rotation.

A lever or handwheel is provided in the cab to control the reverser. It has three principle positions, Full Forward Gear, Mid Gear and Full Reverse Gear. Mid Gear is equivalent to 'neutral' on a road vehicle. There are also intermediate positions to adjust the 'cut off' point for steam admission to the cylinders. An indicator is provided to show the driver the 'cut off' position and the reverser lever is fitted with a locking ratchet to hold it in the required position. Reverser levers are usually purely mechanical devices and require some effort to operate effectively while the locomotive is running since the valve gear is under considerable pressure from steam. Some locomotives are fitted with [steam operated reversers](#).

REVERSER, AIR

A power assisted [reverser](#) which used air pressure supplied from the air brake compressor. The device first appeared in 1882 on the London Brighton & South Coast Railway.

REVERSER, STEAM

A method for operating reversing gear using steam power first introduced by James Stirling in 1874. Two cylinders, one steam and one oil and connected by a rod, were mounted outside the boiler. Often they were fitted inside the cab or housed in an extension of the driving wheel splasher but, if free standing outside the boiler, they looked similar to and could be mistaken for a Westinghouse air brake pump.

The reverser is controlled by two levers in the cab. To move the reverser, steam is admitted to one side or the other of a piston in the steam cylinder. The piston moves the

rod and thus varies the reverser rod position. A separate valve controls the flow of oil in the second cylinder between the two sides of the piston. When the position of the reverser is set by the steam cylinder, it is locked by the oil cylinder. A pointer in the cab provides an indication of the position of the reverser. Single lever controls were later provided for some versions of this and other types of power reverser.

Steam reversers were generally difficult to maintain and were prone to "wandering" off position due to the escape of steam or the leakage of air into the oil cylinder. They often required a degree of "persuasion" or repeated operation to get the reverser set in the correct position.

ROCKING GRATE

A system for allowing the firebars to be shaken by use of controls in the cab, usually hand operated in the UK or steam operated elsewhere. The purpose was to assist with fire cleaning and the break up and disposal of clinker. Rocking grates were common in the US and areas where [coal](#) was poor and caused clinker but were rare in the UK until after the Second World War when the quality of coal had deteriorated.

ROSS POP SAFETY VALVE

A type of [safety valve](#) designed to act in two stages to prevent 'dribbling' of steam from a boiler at full pressure. Designed by RL Ross in 1902 and later to become widely used in the UK.

RUNNING PLATE

The narrow horizontal walkway seen at roughly boiler base level on most steam locomotives, along which it was possible to access parts of the boiler and its attachments. Also sometimes used to provide access to the [motion](#).

[Return to top of page](#)

[To Home Page](#)

S

SADDLE TANK

A tank locomotive which has the water tank mounted on top of the boiler so that they take the form of a saddle.

SAFETY VALVE TYPES

Lock-up, Spring balance, Salter, Pop, Ross Pop are all types of [safety valves](#).

SAFETY VALVES

Pressure relief valves mounted on top of a boiler or firebox (sometimes both on early locomotives) designed to allow steam to escape if the boiler pressure exceeded the design limit

SAND

Gravity fed sanding of rails ahead of driving wheels to assist traction was first tried in the US in 1836 and in the UK in 1838. Steam assisted sanding was introduced in 1886 in an attempt to overcome the problem of side winds blowing the sand away before the wheel passed over it.

SANDBOXES

In the UK, it was the practice to fit the sandboxes near the [running plate](#), sometimes attached to the wheel splashers. US practice was to add a sand dome to the top of the boiler, in an attempt to use the boiler heat to keep the sand dry.

SATURATED STEAM

Steam which has not been [superheated](#). Also known as 'wet steam'.

SCOOP, WATER

See [Water Scoop](#).

SELF-CLEANING SMOKEBOX

A system for removing ash accumulated in the [smokebox](#) using the gases from the fire, first introduced in the UK during the Second World War. A baffle plate placed in front of the [tube plate](#) directed the gases down and forward to lift the ash towards a mesh screen. The screen has the effect of breaking up larger pieces of ash so the flow of gases will expel them through the screen and out of the chimney.

Some earlier systems of smokebox cleaning used a manually controlled blower to lift the ash into the exhaust blast.

SETTING BACK

The act of reversing the locomotive gently into its train in order to reposition the engines (i.e. the pistons in the cylinders) into a more favourable position for starting. Although it is not theoretically possible to leave a locomotive in a position where the engines are unable to start, it can happen that certain starting positions will provide insufficient

power to move a train. The driver will therefore 'set back' to get a more favourable starting position.

SIGHT FEED LUBRICATOR

A locomotive lubricator system where a reservoir of oil mounted in the cab was equipped with glass fronted tube to allow the crew to observe that oil was available.

SINGLE FLUE BOILER

A boiler with only one tube, or flue between the fire at one end and the chimney at the other. This was the type of boiler common before the introduction of the [multi-tube boiler](#) in 1829.

SINGLE

The common term to denote a locomotive with only one driving wheelset. In the older versions, the driving wheel was often very large in proportion to the rest of the locomotive. The design was common in the UK during the 19th Century.

SLIDE VALVE

The traditional valve system used in the steam engine to control the flow of steam into and out of a cylinder. As the name suggests, the valve slides horizontally over the steam ports leading to the cylinder, opening and closing the ports as required to supply steam or exhaust it from the cylinder. Eventually replaced by the [piston valve](#).

SLIDEBARS

A fixed pair of bars fitted at the rear of the [cylinders](#) to guide the [crosshead](#) on which the [connecting rod](#) is connected to the [piston rod](#). The crosshead slides forward and back between the slidebars.

SMALL TUBES

See [Tubes, Boiler](#).

SMOKE DEFLECTORS

Early locomotives had tall chimneys to carry the exhaust clear of the driver's line of sight but, as boilers increased in size, the height of chimneys was reduced to keep locomotives within loading gauge requirements. Smoke deflectors were added on either side of the smoke box of large-boilered locomotives to force air upwards towards the chimney and thus deflect smoke upwards and clear of the cab windows. They were originally a German invention and became common from the 1930s onwards.

SMOKEBOX

The leading end of the boiler through which exhaust steam from the cylinders passes and gases from the fire are drawn to exit via the chimney.

SMOKEBOX DOOR

An opening at the front of the [smokebox](#) to allow access for the removal of ash drawn through the boiler tubes from the fire. The door must be kept air tight to ensure that the maximum draught is available to allow air to be drawn through the fire from the grate.

SNIFTING VALVE

The common name for an [anti-vacuum valve](#).

SPECTACLE PLATE

The transverse member mounted between the locomotive frames to the rear of the cylinders on which parts of the valve gear are hung. Sometimes wrongly used to describe the weather board (q.v.) at the front of the cab.

STAYS

The bolts which secure the inner firebox to the outer firebox. See [firebox](#).

STEAM

Steam is the gas which is given off as a result of boiling water. The normal boiling point of water is 100° C. Unconfined steam will expand to about 1325 times the size of the water from which it came. If it is confined, it will build up pressure which can be harnessed to do work.

Incidentally, it is worth noting that pure steam is actually invisible. The vapour associated with steam which we normally see is really small droplets of water which occur as a result of condensation.

The work which can be extracted from steam is achieved by allowing the natural expansion of the steam as it cools. If the steam is carried away from the source of heat which produced it, it will cool and expand. This expansion can be used to do work, like pushing a piston inside a cylinder.

Steam pressure can also be used to do work as well as expansion. The steam collected by boiling water in a boiler can be contained in the space above the water level while its pressure is increased as more and more water is boiled. Eventually, the pressure reaches

the safe working level of the boiler. Spring-loaded [safety valves](#) are provided to allow steam to escape if the pressure rises above the normal working level.

If you see safety valves "blowing off" steam, you will notice that the steam is actually invisible for a short distance above the valve. Only when it has cooled and expanded will the familiar white plume become clearly visible. During blowing off, the nature of expansion can also be seen as the plume of steam widens the further away from the boiler it goes.

In a steam locomotive, both steam pressure and expansion are used inside cylinders to do the work of moving the machine. Both can be varied by the driver to regulate the power used by the locomotive under the varying circumstances of train operation.

STEAM BRAKE

First used by Stephenson in 1833 on his Patentee locomotive and tried in the US in 1848 on the Boston and Providence RR. Later widely used both separately and in conjunction with automatic brakes, either vacuum or air. The steam brake can be operated by either a separate brake valve in the cab or a combined automatic and loco. brake valve. For more information on train brakes, see our [Brakes Page](#).

STEAM CHEST

The internal part of a locomotive's cylinder block where the valve chamber connects with the steam supply and exhaust pipes.

STEAM PIPE

The pipe which connects the [regulator valve](#) with the cylinder steam chest where the valves are located. Steam passes down this pipe when the regulator valve is opened by the driver. In superheated locomotives, the steam is diverted into the [superheater header](#) before it reaches the steam chest.

STEAM REVERSER

See [Reverser, Steam](#).

STEAM TENDER

A design of tender which had its own engines introduced in 1863 by Archibald Sturrock on the Great Northern Railway of the UK. Two cylinders were mounted inside the tender frames and drove six coupled wheels. The steam was supplied by the locomotive boiler and was exhausted into the tender tank to heat the water. About 50 were built but they

were not considered economic and were later removed. Not to be confused with 'boosters' (q.v.).

STEAM TURRET

See [Turret, Steam](#).

STEPHENSON VALVE GEAR

See [Link Valve Gear](#).

STROKE, PISTON

The length of the movement of the piston inside the cylinder and often quoted as an essential dimension of a locomotive's design.

SUPERHEATED STEAM

Steam which has been reheated or 'dried' after its production in the boiler. Superheated steam has less water vapour and will therefore not condense as rapidly as 'wet' or [saturated steam](#). It can lead to a 25% saving in coal and 30% saving of water consumption.

SUPERHEATER

Equipment provided in a locomotive boiler for producing superheated steam. Early superheaters were fitted in the smokebox and were little more than steam dryers. Later superheaters used enlarged [boiler tubes](#) to dry the steam and raise the temperature to a higher level. The first superheaters, designed by Wilhelm Schmidt in Germany, appeared in 1897. The additional efficiency of the drier steam led to superheaters becoming standard equipment.

SUPERHEATER ELEMENTS

The coils of pipes provided inside the larger flue [tubes](#) of the boiler through which saturated steam from the boiler passes to enable its temperature to be raised.

SUPERHEATER HEADER

The connection box mounted in the [smokebox next](#) to the tube plate which contains the incoming saturated steam pipe and the tubes for [superheating](#) the steam. Some designs of superheater header contained the [regulator valve](#).

SUPERHEATER TUBES

See [Superheater Elements](#).

[Return to top of page](#)

[To Home Page](#)

T

TAIL RODS

Extensions to the [piston rods](#) which protruded through the front of the [cylinders](#) so fitted. Tried from time to time during the 1890s and early 1900s, fitting tail rods was said either to save wear on cylinders or to cause it, depending on who was speaking. They were not taken up universally and many locos which had them when built were later modified to remove them.

TANK LOCOMOTIVE

A steam locomotive which has its coal and water storage on the same frames as the engine. The design first appeared in 1835 in Ireland. The water tanks are the most obvious feature as they are mounted on either side of the boiler partially obscuring it. There are different types of tank engine, side tanks are the most common - see also [Pannier Tank](#) and [Saddle Tank](#). Well tank locomotives, where the tank is hung under the frames, were less common.

TAPERED BOILER

A boiler design where the diameter at the [smokebox](#) end is smaller than at the [firebox](#) end. This was done so that the maximum area possible was available for heating around the firebox. A tapered boiler was first introduced in the US in 1850, where it was referred to as the 'wagon top' boiler.

The design has the added advantage that the joints between the boiler rings do not require to be formed to provide a lap, but they will provide a natural lap.

TENDER

The vehicle attached to a locomotive carrying water and coal (or other fuel). Some locomotives do not have tenders - see [Tank Locomotive](#). The name 'Tender Locomotive' is sometime used to distinguish it from a tank locomotive.

TENDER BRAKE

The only means by which early locomotives were stopped. A hand wheel or lever on the tender was connected to brake blocks acting on the tender wheels.

TESTING PLANT, STATIC LOCOMOTIVE

There were six special steam locomotive static testing stations built in the world: Altoona, Pennsylvania, USA in 1904, Swindon, UK in 1905, Purdue University USA, Grunewald, Berlin, Germany 1931, Vitry, Paris in 1933 and Rugby, UK in 1948.

THERMIC SYPHON

A water passage built into a [firebox](#) in a Y shape so that the base of the Y is turned forward to connect with the water space at the front of the firebox and the two arms open into the [crown](#) space. The purpose was to improve water circulation and its exposure to the hottest heating areas around and in the firebox. First appeared in the 1930s but not used in the UK until 1940 when they were adopted for the Southern Railway 4-6-2 locomotive classes and the abortive "Leader" designed by O.V. Bullied. Popular in the US and France but very complicated to build and maintain in good condition.

THROAT PLATE

The portion of the firebox which joins the boiler barrel. This is a difficult section to form as it is often of an unusual shape to accommodate the change from a circular barrel to a more rectangular and deeper firebox.

TOP FEED

A system of boiler replenishment, first tried in 1863 and occasionally from that time until Churchward of the GWR adopted it in 1906, where the feed water is passed through pipes to the top of the boiler where the non-return valves ([clacks](#)) are mounted and then into the steam space. The water is deposited onto a tray (or series of trays) before it strikes the water surface. The effect is to disperse the water before it mixes with the existing water in the boiler and it was said to reduce boiler maintenance although it was never conclusively proved. It became standard in the UK on most new locomotives from the 1930s.

TRACK PAN

US term for [water trough](#).

TRACTIVE EFFORT

The force exerted at the edge of the driving wheel of a locomotive expressed in pounds.

Calculated as: $TE = (d^2 * n * s * (0.85 * p)) / 2 * D$,

where d = piston diameter (ins.), n = number of cylinders, p = boiler pressure (lb.), s = piston stroke (ins.), D = driving wheel diameter (ins) and P is 85% of boiler pressure (psi).

TUBE CLEANING

The removal of soot and ash from the inside of boiler tubes to ensure the effective generation of the draught for the fire. Was often done with steam lances, latterly with compressed air and accompanied by brushing as required.

During the 1930s some UK locomotives were fitted with steam operated tube-cleaning guns, sometimes referred to as anti-carbonisers. It was possible to direct sand, under steam pressure, to any part of the rear [tube plate](#) from a lever in the cab.

TUBE PLATES

The plates at the leading and rear ends of a boiler which were drilled with holes of the diameter required to hold the [boiler tubes](#). The leading tube plate separated the boiler from the smokebox, while the rear tube plate formed the front of the inner firebox.

TUBES, BOILER

The flues through which the gases from the fire pass to heat the water in the boiler. The gas is drawn through the tubes by the draught created from the exhaust of the steam through the chimney. Tube sizes are often quoted for locomotives because they are an indication of the heating surfaces available for the manufacture of steam. More modern designs of boiler have two sizes of tubes, large tubes for the [superheater elements](#) and small tubes for normal water heating purposes.

TURNTABLE

Rotating section of track used to turn locomotives to face the direction of running required. Originally hand operated, they could later be found to be steam, air or vacuum operated.

TURRET, STEAM

The US term for the steam [manifold](#).

TYRE

The steel ring shrunk (or otherwise fixed) to a railway wheel to provide the bearing surface which will run on the rail. The tyre is usually provided with a [flange](#) to give the guidance required to keep the wheels on the rail. Some locomotive driving wheels did not have a flange because of the need to allow movement round severe curves without the risk of the flange riding up onto the top of the rail and derailing the locomotive.

[Return to top of page](#)

[To Home Page](#)

U

UNIFLOW LOCOMOTIVE

An experimental locomotive which worked on the South Eastern Railway between 1849 and 1852 using a large, externally piped exhaust system. It did not find acceptance and was not used elsewhere.

V

VACUUM BRAKE

The brake system which uses a vacuum formed in the brake pipe and cylinders to effect a brake release and the replacement of the vacuum by atmospheric pressure to cause an application. The automatic vacuum brake was first used in the UK in 1878. See more details in our [Brake Pages](#).

VACUUM TURNTABLE

A turntable operated by vacuum power provided by the locomotive being turned.

VALANCE

The angled plate attached to the edge of a locomotive running plate to provide strength.

VALVE GEAR

The system of rods, levers, cranks and eccentrics which provide the links between the pistons, valves and wheels of a steam engine. The two main parts consisted of the piston rod, connecting rod and crank which transmitted the drive from the piston to the wheel and the eccentrics, eccentric rods and valve rods which transmit motion from the

axle to the valve. For excellent live working programme see [Valve Gear for the Computer](#).

VALVE SETTING

The action of fitting and adjusting the locomotive [valve gear](#) to ensure the most efficient operation of the valves. This was a difficult job to do well and required skilled fitters with a thorough knowledge of the equipment in their care. Many experimental valve gears introduced during the years of steam locomotive development failed to gain acceptance because the fitters working on them in sheds did not understand them properly.

VON BORRIES COMPOUND

A system of [compounding](#) where the low and high pressure cylinders drove the same axles requiring that the [valve gear](#) be adjusted to ensure that the same level of work was done in both cylinders at the same time. It was used by TW Worsdell in 1884 on the Great Eastern Railway and later on the North Eastern Railway and by Beyer Peacock for some locomotives built by them in the 1890s.

[Return to top of page](#)

[To Home Page](#)

W

WALSCHAERTS VALVE GEAR

A form of link motion [valve gear](#) first patented in 1844 by Egged Walschaerts, a Belgian engineer. It first appeared on a British railway in 1878 when an 0-4-4 tank locomotive fitted with it was purchased by the Swindon, Marlborough and Andover Railway. It did not become popular in Britain until the twentieth century but it is now generally regarded as the best valve gear design, being easier to maintain and lighter than Stephenson valve gear. It first appeared in the US in 1876 and was also widely adopted there and on the continent of Europe.

WASHOUT

The process of removing sludge and scale from the inside of a locomotive [boiler](#). The boiler was first emptied of steam and the hot water drained off. Water was then hosed

into the boiler through 'washout plugs' while long rods were inserted into the plug holes to remove scale from the interior surfaces. After cleaning, the boiler was inspected for defects. Washouts used to be needed on a weekly basis for many locomotives but varied according to the age of the locomotive, the design of the boiler, its usage and the type of water used.

WASHOUT PLUGS

In order to allow all the parts of the boiler interior to be reached during a washout, a number of plugs were provided in strategic positions. They were screwed into the boiler shell and were often numbered to ensure that they are replaced in the correct positions. Washout plugs were also useful for inspection purposes. A modern locomotive may have had over 40 washout plugs located around the boiler and firebox.

WATER COLUMN

A hollow pole fitted with a leather hose and connected to a water supply for filling locomotive water tanks.

WATER CRANE

A type of [water column](#) with a movable arm which allows water to be supplied to locomotives on either of two adjacent tracks.

WATER GAUGE

Also referred to as "water glass" in the US. The indication provided in every locomotive cab showing the level of water in the [boiler](#). Always provided in pairs, the water gauges were considered the most important part cab equipment. Cocks were provided at the top and bottom of the gauges to test the connections above and below the boiler water level and thus ensure accuracy of indications.

WATER SOFTENING

The addition of chemicals to hard water to reduce the scale generated when boiled. Widely used in the UK.

WATER SCOOP

A device, first used on locomotives of the LNWR in the UK in 1860 to allow water to be collected from a [water trough](#) laid along the track whilst the train was moving. The scoop was mounted on the tender and was lowered by hand when required to collect water.

It was essential that the crew raised the scoop before the end of the trough or before the tender was filled to capacity and water spilled through the vent at the tender top. If it did, the leading vehicle would be showered with the excess water and, if there were any open windows, so would the unsuspecting passengers inside.

WATER TROUGH

A channel laid between the running rails and filled with water, which can be collected by passing locomotives fitted with a [water scoop](#). Water troughs were first introduced in the UK in 1860 and in the US in 1870, where they are known as 'Track Pans'.

WATER TUBES

A system which tried to improve the circulation of water between the legs of the firebox by joining them with tubes running across the firebox. The best-known UK example was applied by Drummond on some London & South Western Railway locomotives between 1897 and 1912. The expense of maintaining them outweighed the benefits and they were not universally adopted.

WEATHER BOARD

A vertical sheet added to the rear of the firebox and fitted with two glass portholes to provide some protection for the locomotive crew. They first began to appear in the 1850s.

WEDGE VALVE GEAR

A type of [valve gear](#) designed by Isaac Dodds, dating from 1839 and used occasionally until 1872, which had two eccentrics on a two-cylinder locomotive instead of four. The single [eccentric](#) for each cylinder was changed from forward to reverse by drawing a wedge along a square section of the axle through the sheave to adjust its eccentricity. The design failed because of the difficulty of keeping the wedges properly adjusted.

WESTINGHOUSE BRAKE

Air brake system first invented by George Westinghouse in 1869. It comprised an air pump powered by steam, which provided the air pressure used in the brake cylinders. An automatic version was patented in 1872. This had a brake pipe running the length of the train which was filled with compressed air to release the brakes and to recharge air reservoirs on each vehicle. To apply the brake, the air in the brake pipe was reduced and a 'triple valve' on each vehicle caused air in the reservoir to pass into the brake

cylinder and apply the brakes. The system formed the basis of all future railway automatic air brake types.

Due partly to its cost, the Westinghouse brake was not favoured in the UK, only a few companies adopting it, but it, and its derivatives, became universal in the US. See more details in our [Brake Pages](#).

WET STEAM

The generic term for steam produced in a boiler and collected in the steam space above the water level. It still contains an amount of water vapour which will quickly condense as the steam enters a cold cylinder. Wet steam can be dried by 'superheating' (q.v.).

WHEEL BALANCING

The method of reducing the [hammer blow](#) caused by the action of the pistons driving the cranks as the [crank](#) approaches bottom dead centre. Driving wheels had weights fitted into their rims to act as a [counter balance](#).

WHISTLE

First fitted to a locomotive of the Leicester & Swannington Railway in 1833 following an accident at Thornton when a train hit a horse and cart. Whistles soon became important for transmitting warnings to signalmen describing train routes at junctions and to guards to signal for brakes etc. Most railways proscribed a series of codes for whistles.

WHITE FEATHER

Nickname for the steam seen escaping for the [safety valves](#) when there is full pressure in the boiler.

WHEEL ARRANGEMENT SYSTEMS

Different systems for denoting wheel arrangements have been developed in different countries. In the US and UK is usual to refer to a steam locomotive wheel layout numerically by first the leading carrying wheels, then the coupled wheels (including the driving wheels) and finally the trailing carrying wheels, in that order, in a system invented by Frederic M Whyte in the US in 1900 e.g.

4-4-0 = ooOO

4-6-2 = oo000o

0-4-2 = 00o

0-6-0 = 000

2-10-2 = o00000o

A list of US wheel arrangements is available [here](#) on the [Wes Barris US Steam](#) locomotive site.

Some European railways used the Whyte system except that the number of axles was used instead of the number of wheels, 4-6-2 becoming 231. This was developed by the French who used numbers for non driven axles and letters for driven axles, thus 2C1 and which was further modified by Bullied who reorganised it so that the non-driven axles were listed first in order, then the driven axles, thus 21C.

WHYTE WHEEL NOTATION

See 'Wheel Arrangement Systems'. For a list of types and their nicknames, see the [Steam Locomotive Wheel Arrangements](#) page on this site.

WOOTEN FIREBOX

Developed to allow locomotives to burn anthracite.

SOURCES

1. Internet: Railway Technical Web Pages. <http://www.railway-technical.com/index.shtml>